



Energy Related Products

SUPER DC INVERTER SERIES

Service Manual 2016

LFIS-C1-1601



Part 1 General Information 1

Part 2 Indoor Units 6

Part 3 Outdoor Units..... 94

Part 4 Installation..... 107

Part 5 Electrical Control System 142

※The specifications, designs, and information in this book are subject to change without notice for product improvement.

Part 1

General Information

1. Model Lists	2
2. External Appearance	3
2.1 Indoor Units	3
2.2 Outdoor Units	4
3. Nomenclature.....	5

1. Model Lists

1.1 Indoor Units

R410A (capacity multiplied by 1000Btu/h)

Type	Function	12	16	18	24	30	36	42	48	55
Super slim cassette	Cooling and heating			•	•	•	•	•	•	•
Duct	Cooling and heating	•		•	•	•	•	•	•	•
Ceiling-floor	Cooling and heating			•	•	•	•	•	•	•
Four-way cassette(compact)	Cooling and heating	•		•						
Console	Cooling and heating	•	•							
M floor-standing	Cooling and heating				•					
GA floor-standing	Cooling and heating									•

1.2 Outdoor Units

Universal Outdoor unit Model	Compressor type	Compressor Brand	Matched indoor units
MOB30U-12HFN1-QRD0W	Rotary	GMCC	MCA3U-12HRFN1-QRD0W MTBU-12HWFN1-QRD0W MFAU-12HRFN1-QRC8W
MOB30U-16HFN1-QRC8W	Rotary	GMCC	MFA-16HRFN1-QRC8W
MOB30U-18HFN1-QRD0	Rotary	GMCC	MCA3-18HRFN1-QRD0 MCD-18HRFN1-QRD0 MTB-18HWFN1-QRD0 MUE-18HRFN1-QRD0
MOCA30U-24HFN1-QRD0	Rotary	GMCC	MCD-24HRFN1-QRD0 MTB-24HWFN1-QRD0 MUE-24HRFN1-QRD0 MFM-24HRFN1-QRD0
MOD30U-30HFN1-QRD0	Rotary	GMCC	MCD-30HRFN1-QRD0 MTB-30HWFN1-QRD0 MUE-30HRFN1-QRD0
MOD30U-36HFN1-QRD0	Rotary	GMCC	MCD-36HRFN1-QRD0 MTB-36HWFN1-QRD0 MUE-36HRFN1-QRD0
MOD30U-36HFN1-RRD0	Rotary	GMCC	
MOD30U-42HFN1-QRD0	Rotary	GMCC	MCD-42HRFN1-QRD0 MTB-42HWFN1-QRD0 MUE-42HRFN1-QRD0
MOD30U-42HFN1-RRD0	Rotary	GMCC	
MOE30U-48HFN1-QRD0	Rotary	GMCC	MCD-48HRFN1-QRD0 MTB-48HWFN1-QRD0 MUE-48HRFN1-QRD0
MOE30U-48HFN1-RRD0	Rotary	GMCC	
MOE30U-55HFN1-RRD0	Rotary	GMCC	MCD-55HRFN1-QRD0 MTB-55HWFN1-QRD0 MUE-55HRFN1-QRD0 MFGA-55ARFN1-RRD0(B)

2. External Appearance

2.1 Indoor Units

Super slim cassette



Duct



Ceiling-Floor



Compact Four-way cassette



Console



M Floor-standing



GA Floor-standing



2.2 Outdoor Units

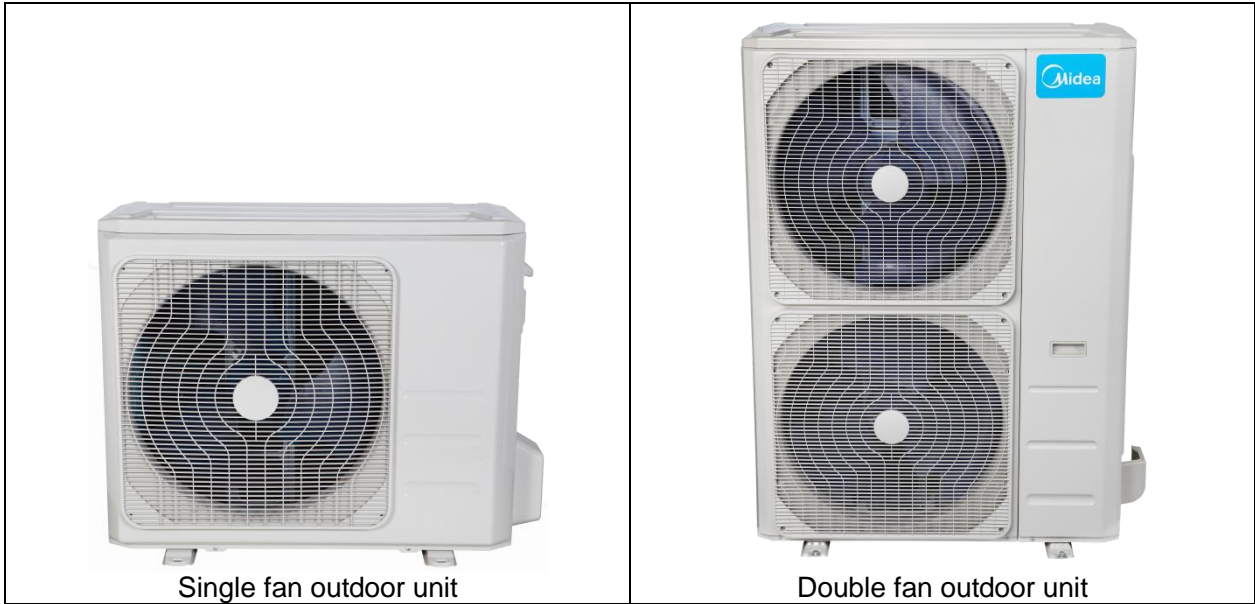

3. Nomenclature

3.1 Indoor Unit

M U B T- 36 H R D N1- Q RC4

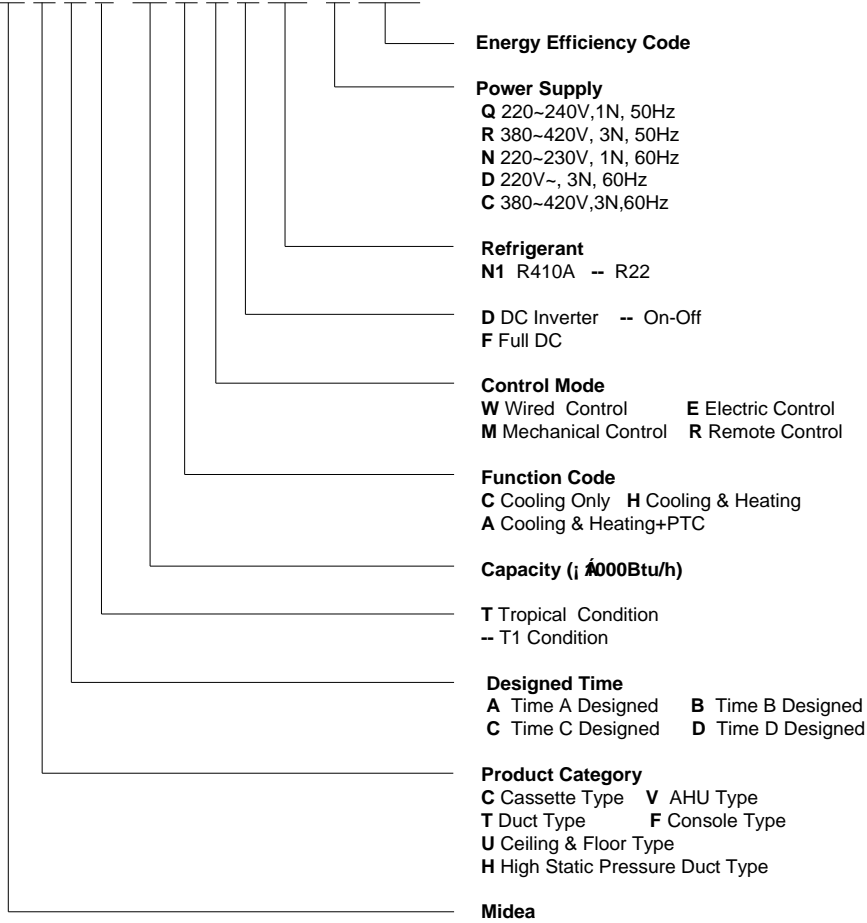

3.2 Outdoor Unit

M O T4 D30 U- 36 H D N1- R RC4

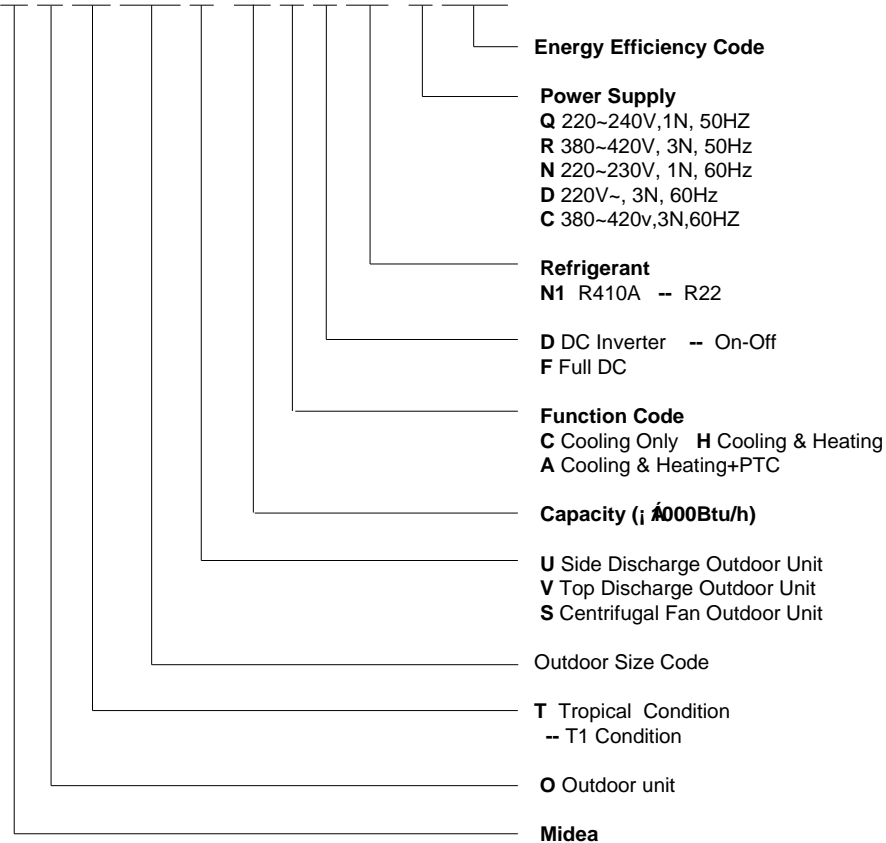

Part 2

Indoor Units

Super Slim Cassette Type.....	7
Duct Type.....	22
Ceiling & Floor Type	38
Four-way Cassette Type (Compact)	52
Console Type.....	61
M Floor-standing Type.....	73
GA Floor-standing Type	83

Super Slim Cassette Type

1. Features	8
2. Dimensions	11
3. Service Space.....	12
4. Wiring Diagrams	13
5. Air Velocity Distributions (Reference Data)	14
6. Electric Characteristics	17
7. Sound Levels	18
8. Accessories.....	19
9. The Specification of Power	20
10. Field Wiring	21

1. Features

1.1 Overview

- Compact design, super slim body size, less space requiring in installation
- Each louver can be separately controlled, more comfort air blowing is possible.
- Auto-lifting panel design, more convenient to clean and maintain the filter. (optional)

1.2 Fresh air intake function

- Fresh air fulfills air quality more healthy and comfortable.
- Ventilation motor is optional to increase the effect of fresh air.



1.3 Optional ionizer generator

- Ionizer generator is optional to get refreshing air to your room.

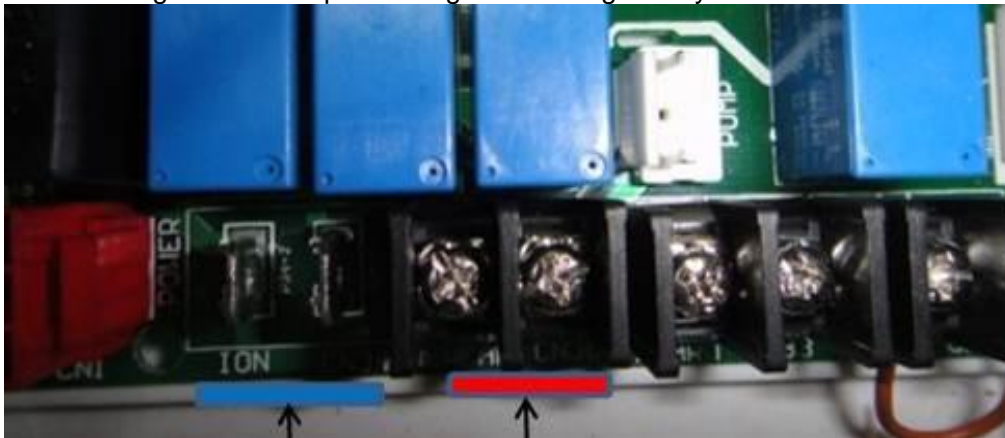

Ionizer generator
connector

Ventilation motor
connector

- Ionizer can be switched on or off by remote controller. When pressing the Clean Air button on the remote controller, ionizer will work and the indicator light on display board will shine.



1.4 External air duct design

- Reserve external air duct, more flexible for the air supply.

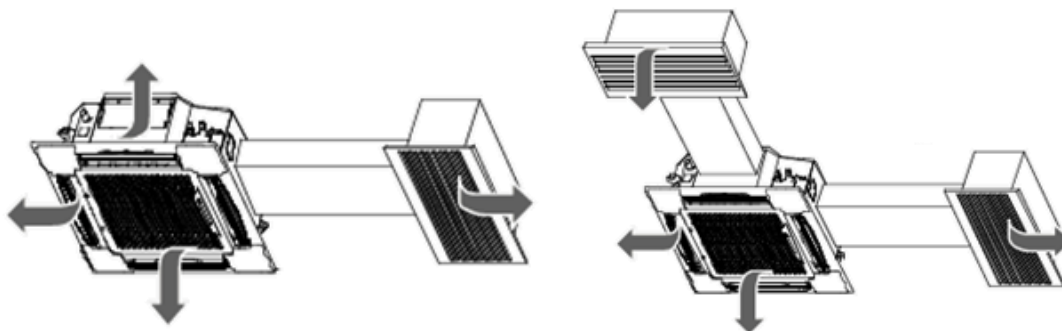

1.5 Built-in draining pump

- Due to the improvement of structure, more convenient to repair or replace the draining pump.

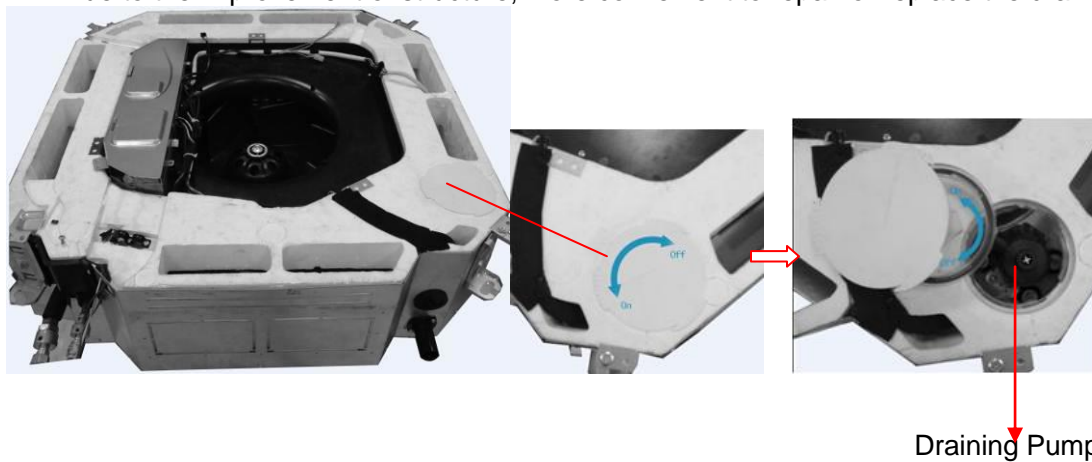

Draining Pump

- Built-in draining pump to make sure condensed water drain out reliably.

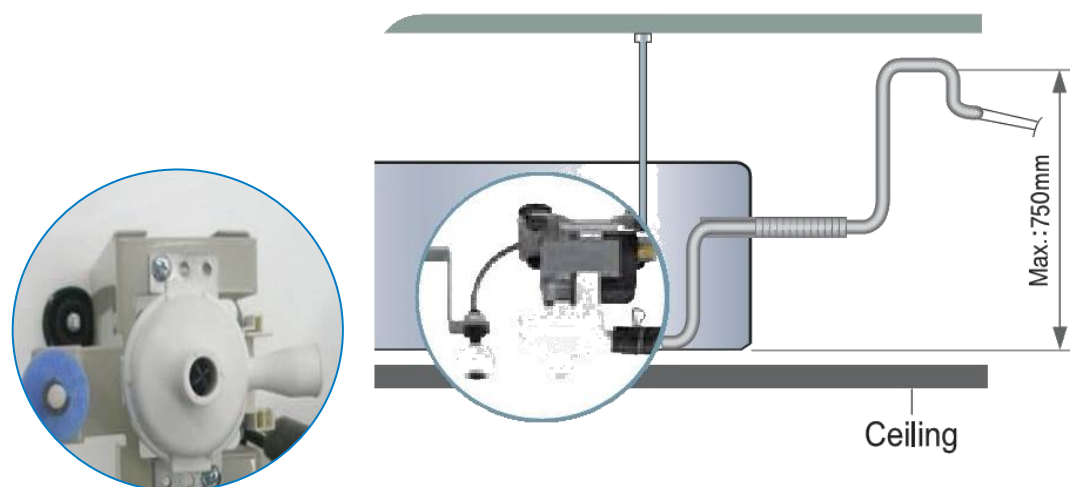

Ceiling

1.6 Terminals for alarm lamp and long-distance on-off controller connection are standard

- Reserve terminals for the connection of alarm lamp and long-distance on-off controller, more human control.



Alarm lamp

Long-distance on-off controller

1.7 Twins Combination(18k-30k)

- The units can be installed as Twin systems: one outdoor unit can connect with two indoor units. The indoor units can be combined in any of the different available ratings.

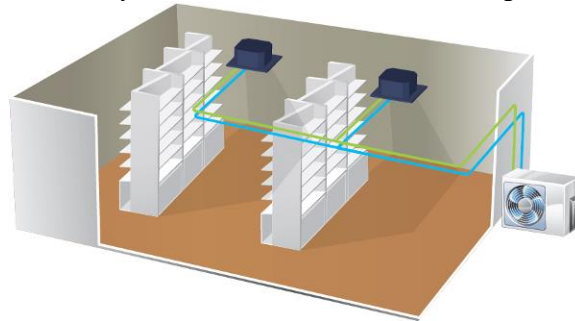

2. Dimensions

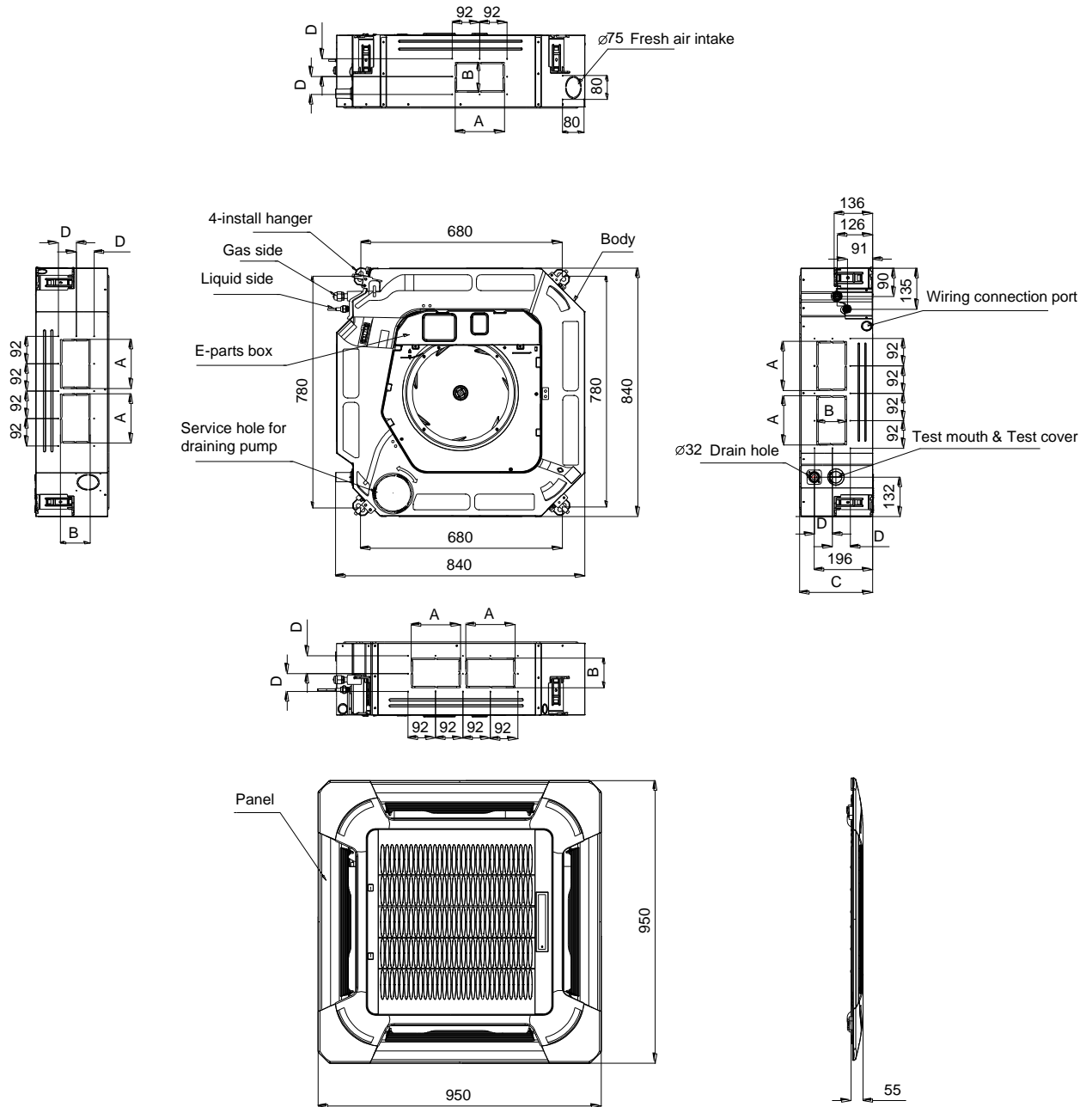

Unit: mm				
Model	A	B	C	D
MCD-18HRFN1-QRD0	160	75	205	50
MCD-24HRFN1-QRD0	160	95	245	60
MCD-30HRFN1-QRD0				
MCD-36HRFN1-QRD0				
MCD-42HRFN1-QRD0				
MCD-48HRFN1-QRD0	160	95	287	60
MCD-55HRFN1-QRD0				

3. Service Space

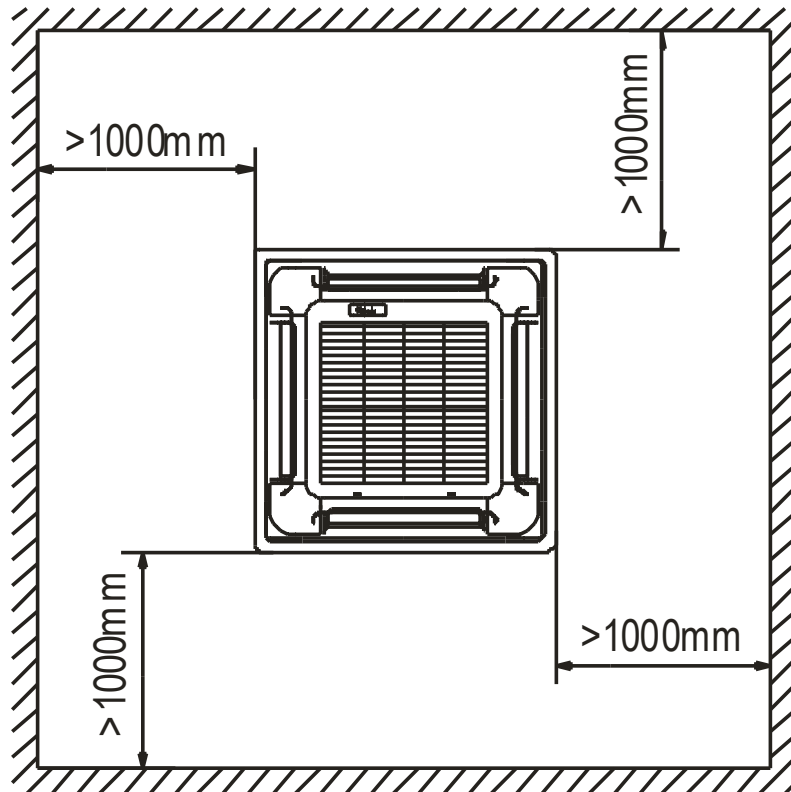

4. Wiring Diagrams

MCD-18HRFN1-QRD0 MCD-24HRFN1-QRD0 MCD-30HRFN1-QRD0 MCD-36HRFN1-QRD0
 MCD-42HRFN1-QRD0 MCD-48HRFN1-QRD0 MCD-55HRFN1-QRD0

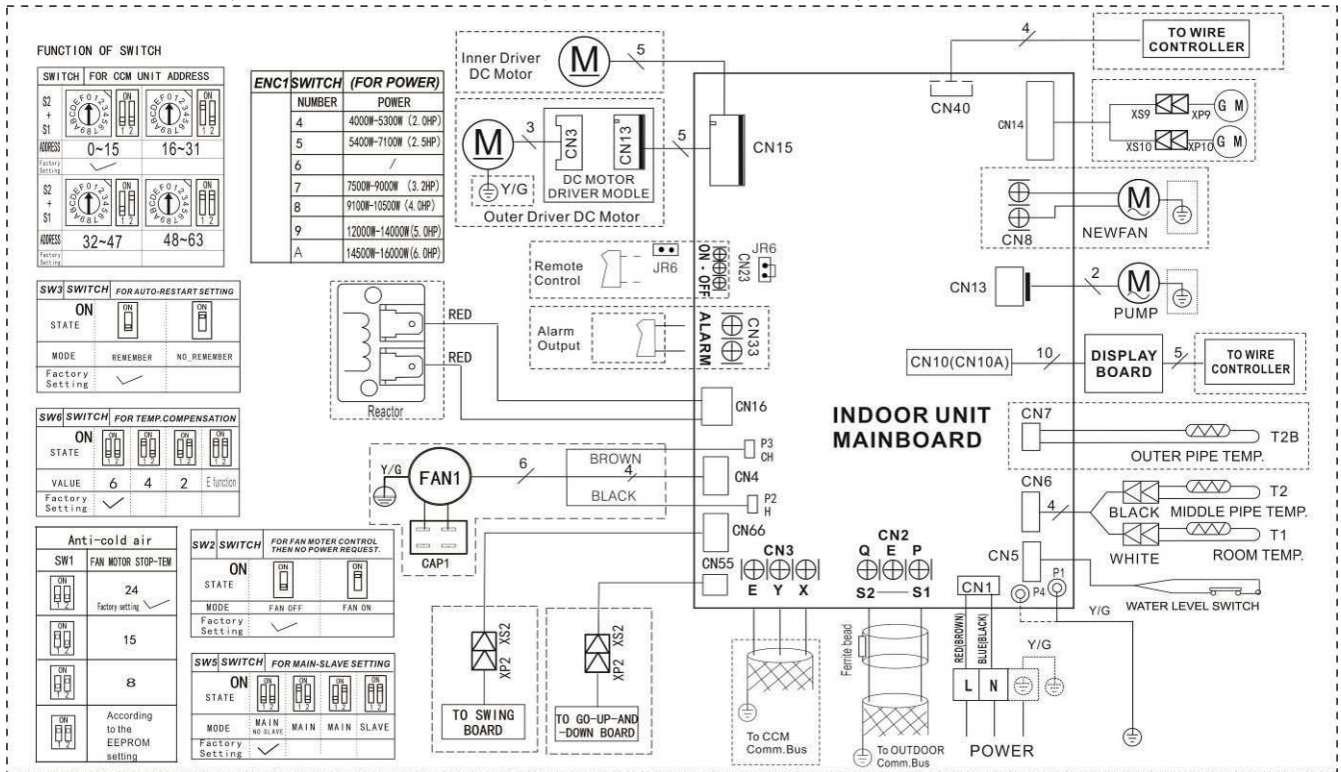

5. Air Velocity Distributions (Reference Data)

18-24K:
Cooling:

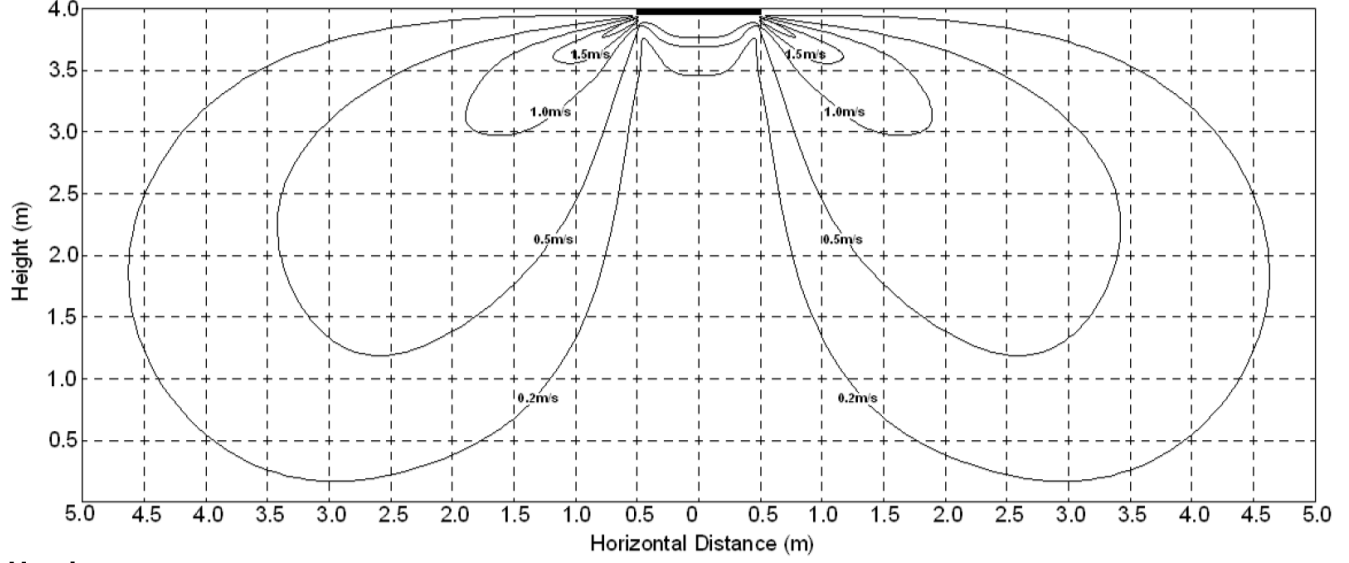

Heating:

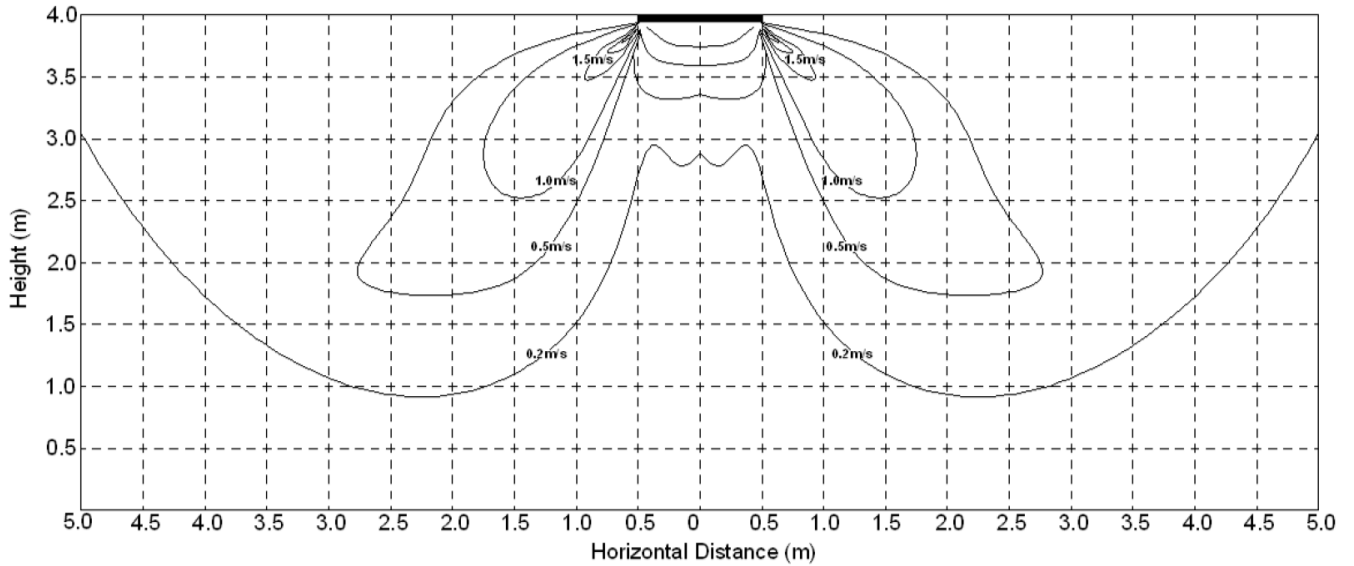

**30-42K:
Cooling:**

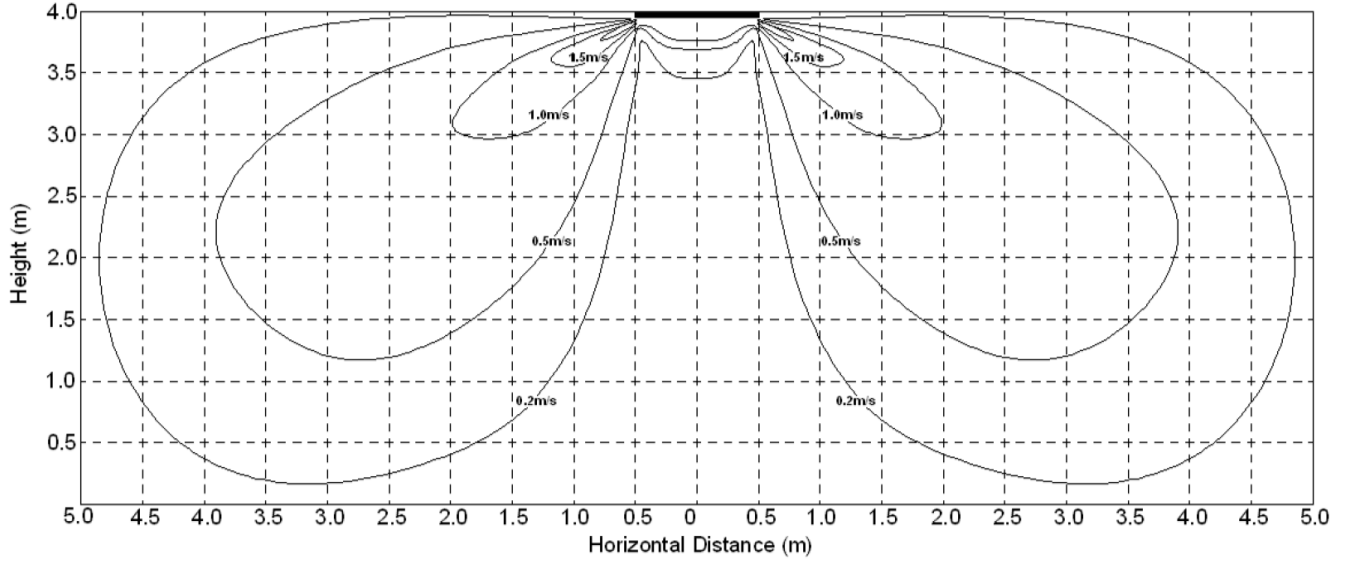

Heating:

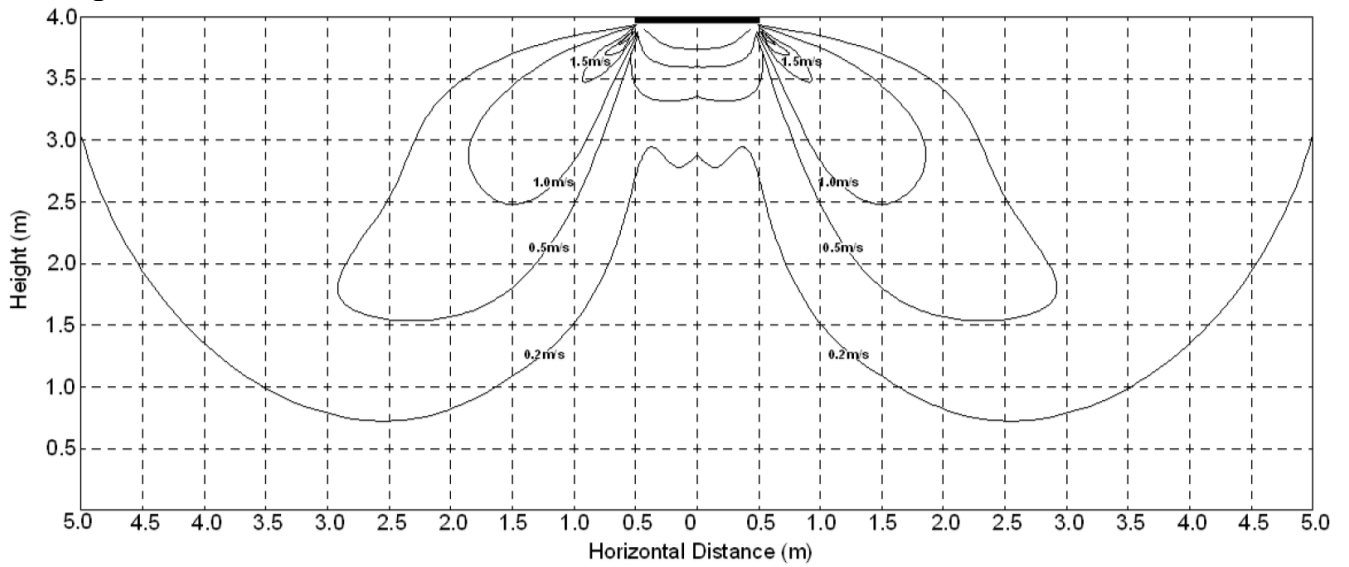

48-55K :

Cooling:

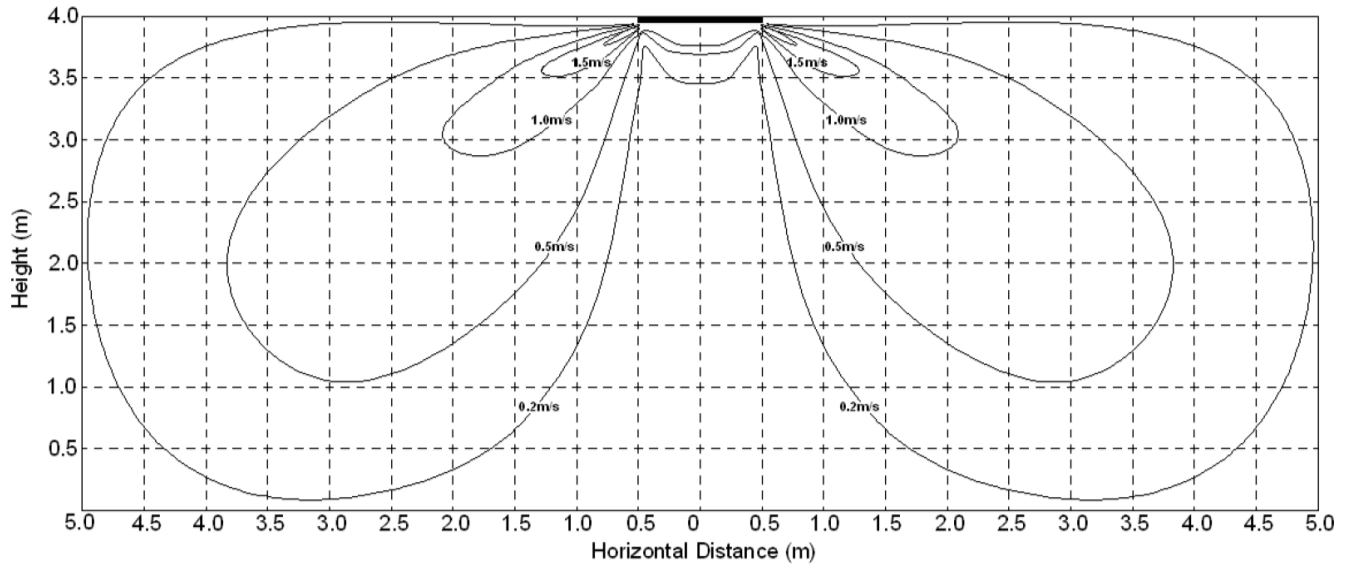

Heating:

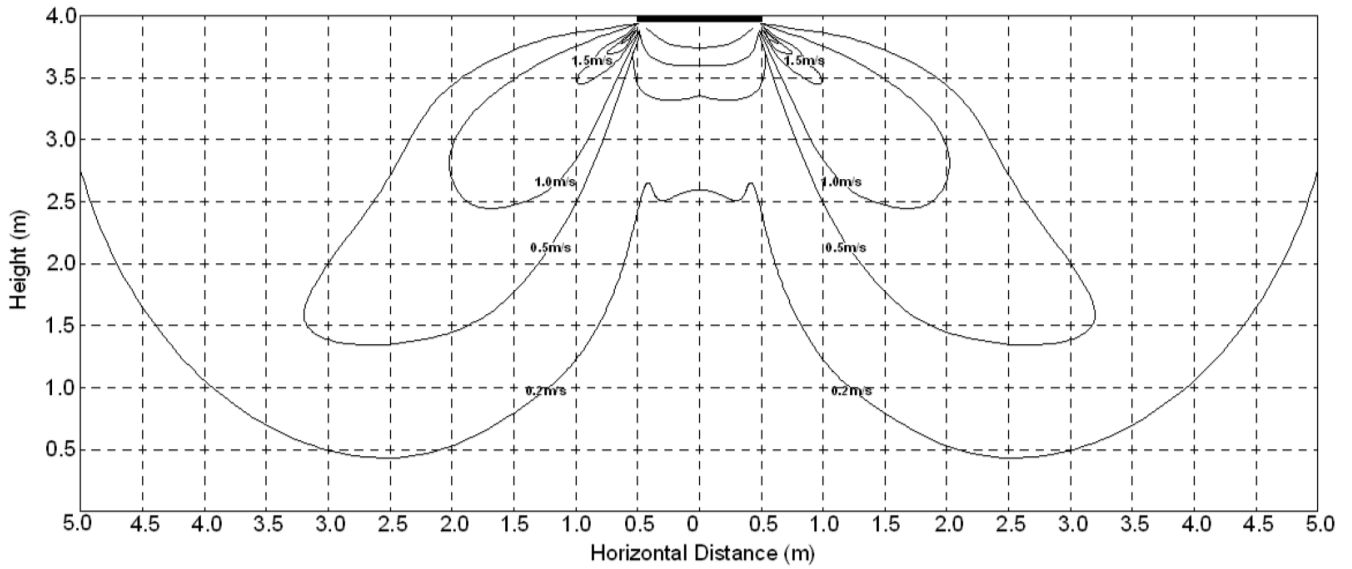

6. Electric Characteristics

Model	Indoor Unit				Power Supply
	Hz	Voltage	Min	Max	MFA
MCD-18HRFN1-QRD0	50	220-240V	198V	254V	/
MCD-24HRFN1-QRD0	50	220-240V	198V	254V	/
MCD-30HRFN1-QRD0	50	220-240	198	254	/
MCD-36HRFN1-QRD0	50	220-240V	198V	254V	/
MCD-42HRFN1-QRD0	50	220-240V	198V	254V	/
MCD-48HRFN1-QRD0	50	220-240V	198V	254V	/
MCD-55HRFN1-QRDO	50	220-240V	198V	254V	/

Notes:





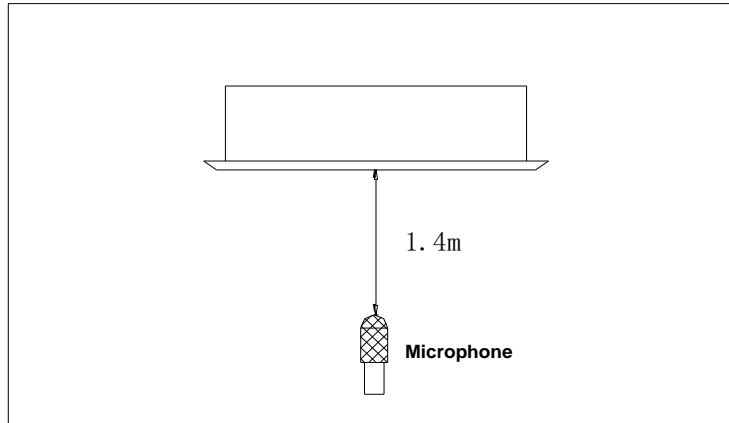











MFA: Max. Fuse Amps. (A)

7. Sound Levels



Model	Noise Power dB(A)	Noise level dB(A)		
		H	M	L
MCD-18HRFN1-QRD0	56	46	41	37
MCD-24HRFN1-QRD0	62	46	42	39
MCD-30HRFN1-QRD0	65	53	48	44
MCD-36HRFN1-QRD0	65	56	52	48
MCD-42HRFN1-QRD0	64	52	40	47
MCD-48HRFN1-QRD0	65	55	51	48
MCD-55HRFN1-QRD0	69	52	49	46

8. Accessories

	Name	Shape	Quantity
Installation Fittings	Installation paper board		1
Tubing & Fittings	Soundproof / insulation sheath		1
Drainpipe Fittings	Out-let pipe sheath		1
	Out-let pipe clasp		1
	Drain joint		1
	Seal ring		1
Remote controller & Its Frame (The product you have might not be provided the following accessories)	Remote controller & Its Frame		1
	Remote controller holder		1
	Mounting screw(ST2.9x10-C-H)		2
	Remote controller manual		1
	Alkaline dry batteries (AM4)		2
Others	Owner's manual		1
	Installation manual		1
Installation accessory (The product you have might not be provided the following accessories)	Expansible hook		4
	Installation hook		4
	Orifice		1

9. The Specification of Power

Model(Btu/h)		18000~24000	30000	36000	36000
POWER	Phase	1-phase	1-phase	1-phase	3-phase
	Frequency and Voltage	220-240V, 50Hz	220-240V, 50Hz	220-240V, 50Hz	380-420V, 50Hz
	POWER WIRING (mm ²)	3x2.5	3x2.5	3x4.0	5x2.5
CIRCUIT BREAKER/Fuse (A)		30/20	40/30	40/30	30/20
Indoor/Outdoor Connecting Wiring (Weak Electric Signal) (mm ²)		2x0.2	2x0.2	2x0.2	2x0.2
Indoor/Outdoor Connecting Wiring (Strong Electric Signal) (mm ²)		3x1.0	3x1.0	3x1.0	3x1.0

Model(Btu/h)		42000~48000	42000~60000
POWER	Phase	1-phase	3-phase
	Frequency and Voltage	220-240V, 50Hz	380-415V, 50Hz
	Power Wiring (mm ²)	3x4.0	5x2.5
Circuit Breaker/Fuse(A)		40/35	30/25
Indoor/Outdoor Connecting Wiring(Weak Electric Signal) (mm ²)		2x0.2	2x0.2
Indoor/Outdoor Connecting Wiring(Strong Electric Signal) (mm ²)		3x1.0	3x1.0

10. Field Wiring

Air Condition Link-Circuit

202044790380

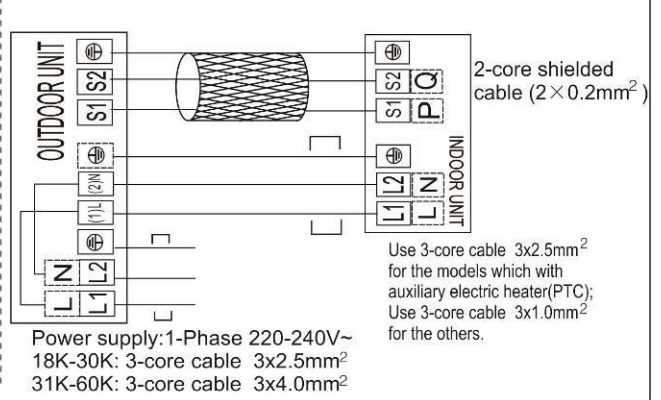
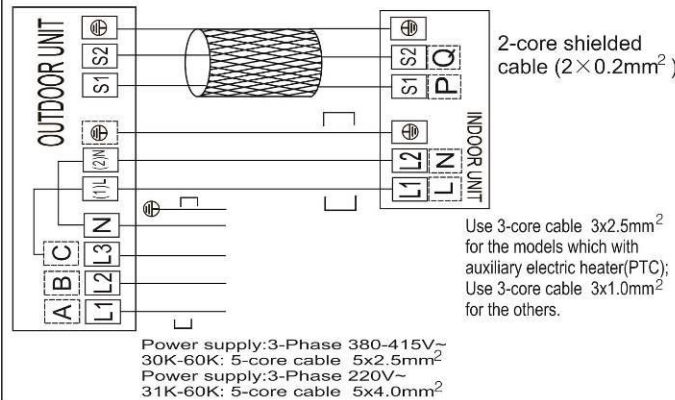
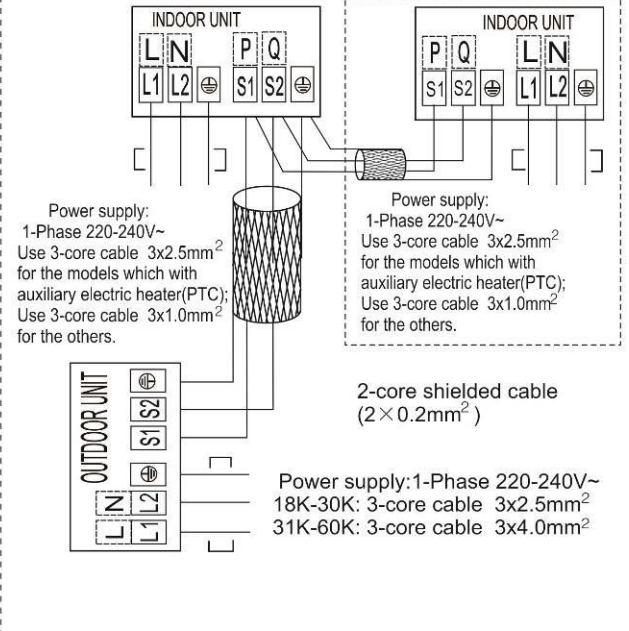
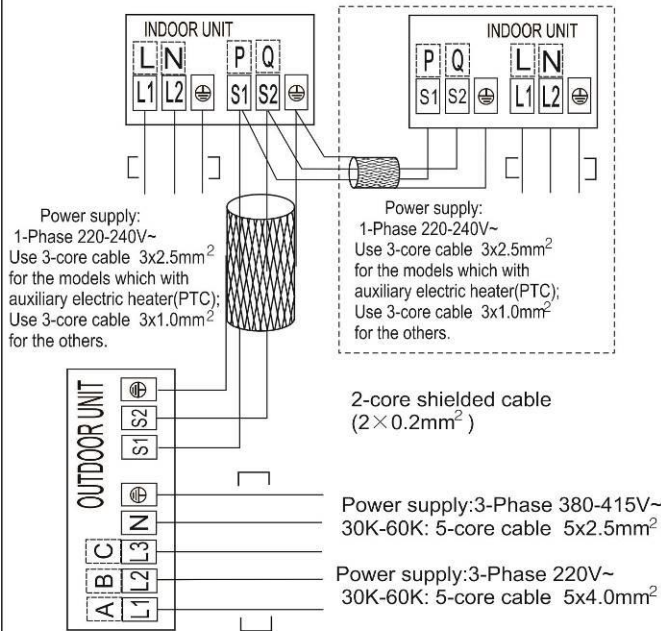

Duct Type

1. Features	23
2. Dimensions	26
3. Service Space.....	27
4. Wiring Diagrams	28
5. Static Pressure	30
6. Electric Characteristics	33
7. Sound Levels	34
8. Accessories.....	35
9. The Specification of Power	36
10. Field Wiring	37

1. Features

1.1 Installation accessories: (Optional)

- Front Board, Canvas Air Passage, Filter, Panel, for easy installation

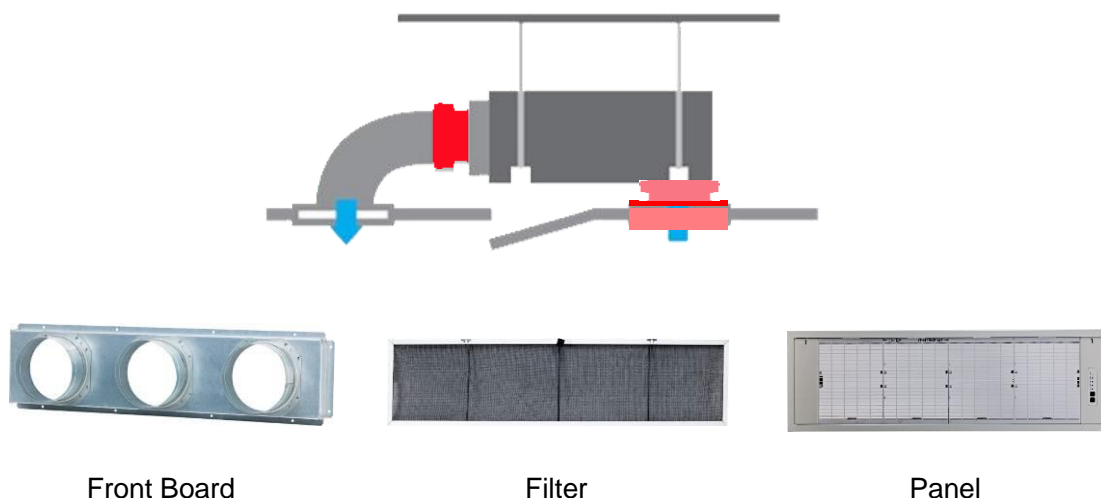

1.2 Easy Installation: Two air inlet styles (Bottom side or Rear side)

- Air inlet from rear is standard for all capacity; air inlet from bottom is optional.
- The size of air inlet frame from rear and bottom is same, it's very easy to move the cover from bottom to rear side, or from rear to the bottom, in order to matching the installation condition.

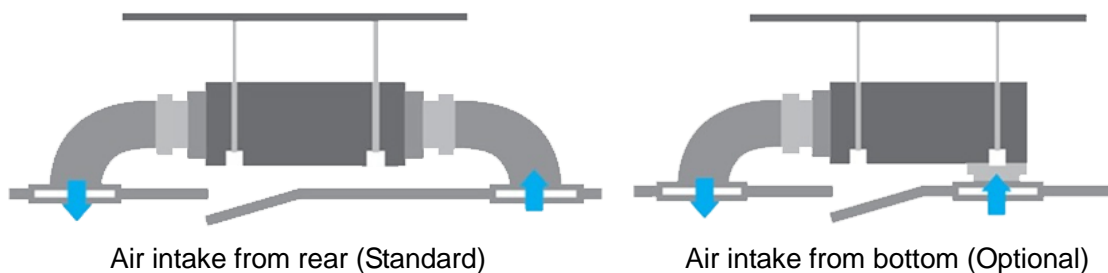

1.3 Fresh air intake function(Optional for 18~60k)

- Install one duct from the reserved fresh-air intake to outdoor. Continually inhale the fresh air to improve the quality of the indoor air, fulfills air quality more healthy and comfortable.

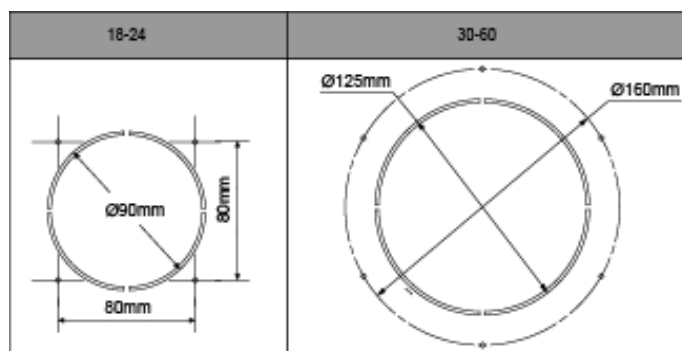

1.4 Easy maintenance

- Clean the filter (Optional, standard product without filter)
It is easy to draw out the filter from the indoor unit for cleaning, even the filter is installed in rear side or bottom side.

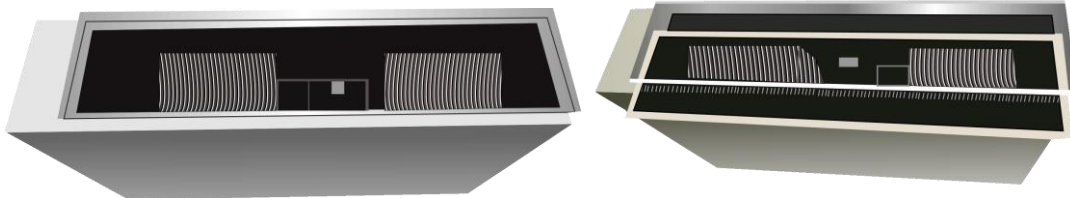

- Replace the motor or centrifugal fan
Remove the ventilated panel firstly. Remove a half of blower housing and take out the motor with centrifugal fan. Directly remove two bolts, and then replace the motor or centrifugal fan easily.

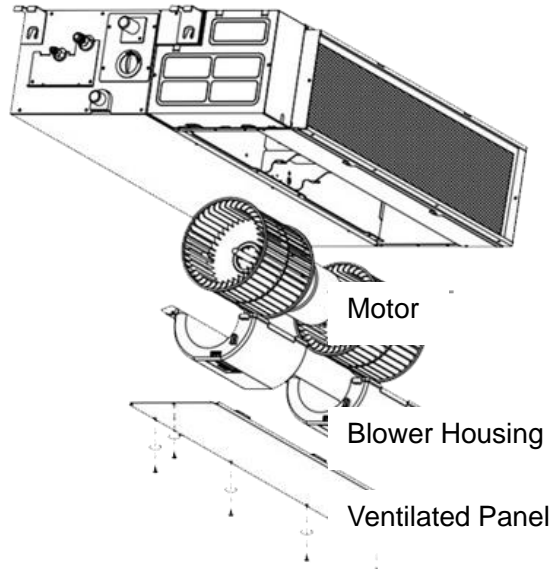

1.5 Reserved remote on-off and central control ports

- Reserved remote on-off ports and central control ports, can connect the cable of an on-off controller or a central controller to realize remote on-off control function or group control function.

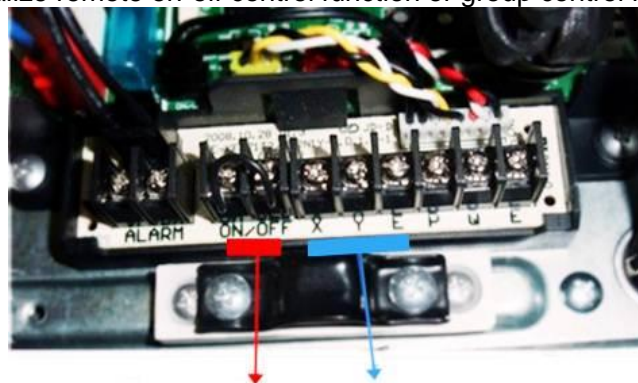

Remote on-off ports Central control ports

1.6 Built-in drain pump (Optional):

- Built-in drain pump can lift the water to 750mm upmost. It's convenient to install drainage piping under most space condition.

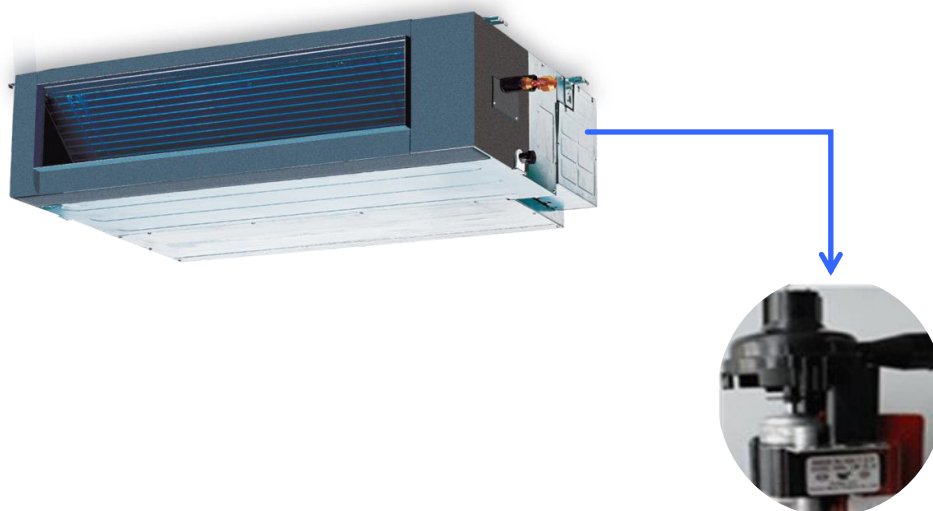
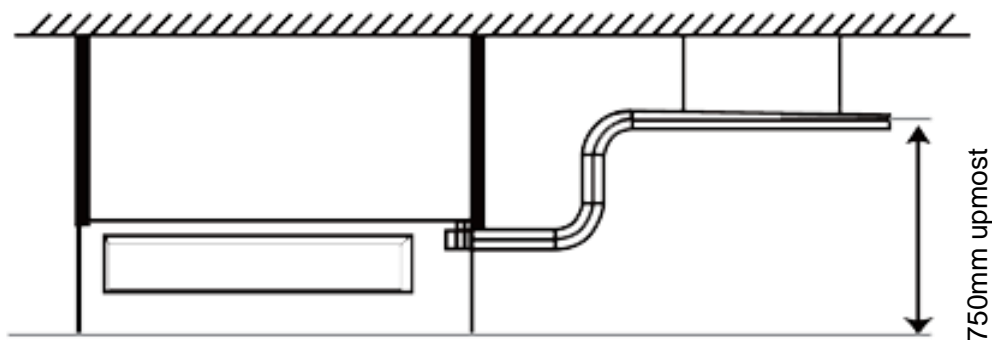

1.7 Built-in display board

- The standard indoor unit can be controlled by wired controller.
- There is a display board with a receiver in the E-box. Move out the display, and fix it in other place, even in the distance of 10m. The unit will realized remoter control.
- The wired controller and the display board can display the error code or production code when the chips detect some failure.

Wired Controller (Standard)

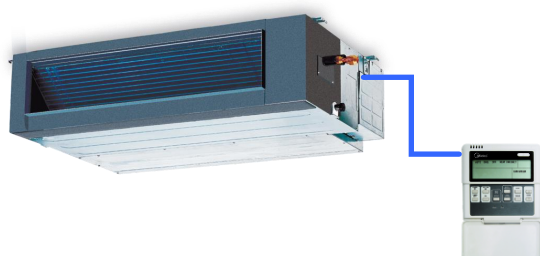

Remote Controller (Optional)

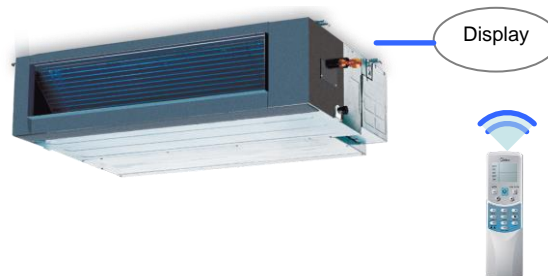

1.8 Twins Combination

- The units can be installed as Twin systems: one outdoor unit can connect with two indoor units. The indoor units can be combined in any of the different available ratings.

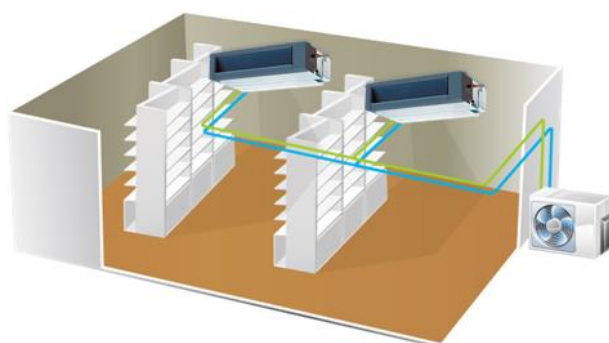

2. Dimensions

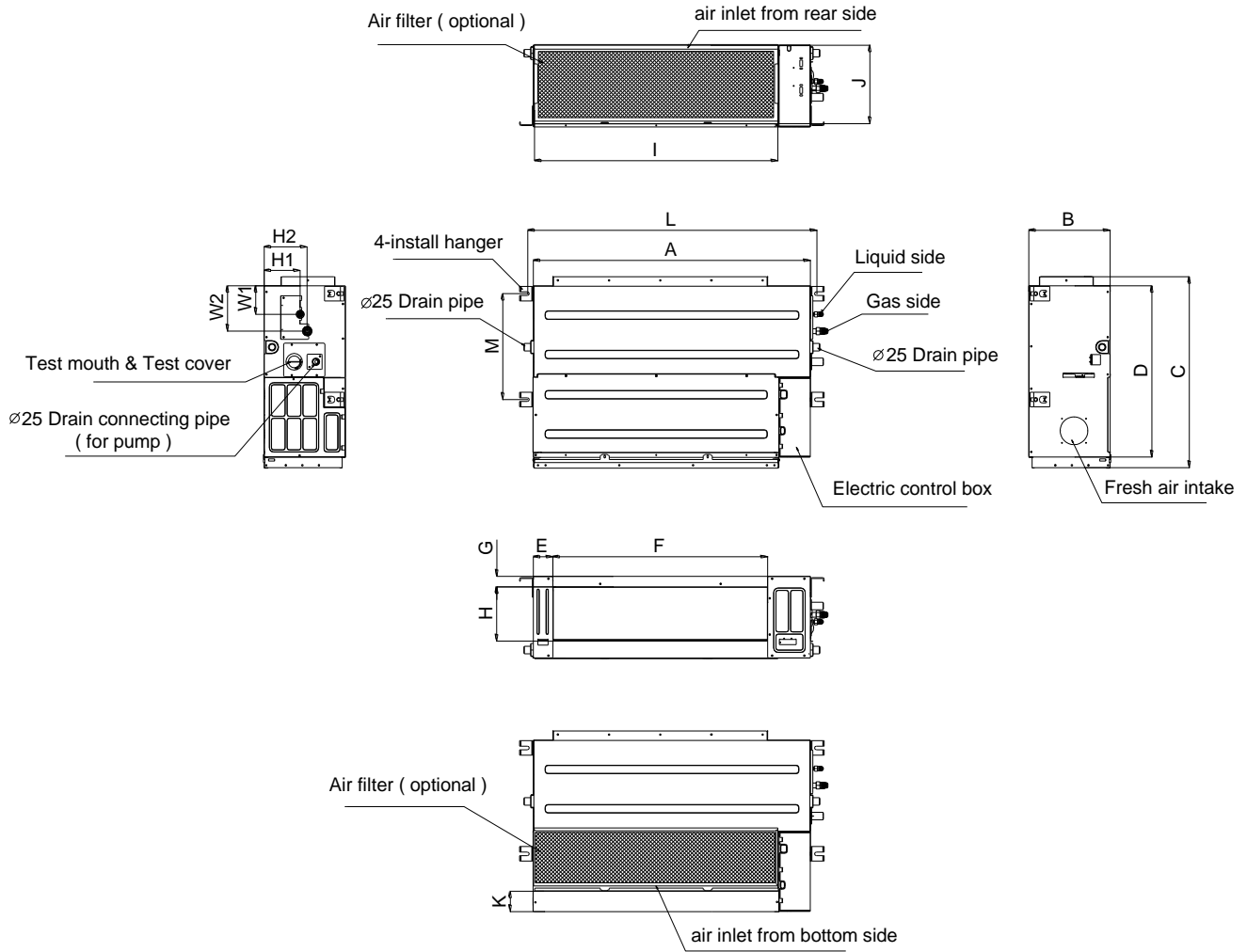

Note: standard product without filter														Unit: mm			
Model	Outline dimension(mm)				Air outlet opening size				Air return opening size			Size of install hanger		Size of refrigerant pipe			
	A	B	C	D	E	F	G	H	I	J	K	L	M	H1	H2	W1	W2
MTBU-12HWFN1-QRD0W	700	210	635	570	65	493	35	119	595	200	80	740	350	120	143	95	150
MTB-18HWFN1-QRD0 MTB-24HWFN1-QRD0	920	270	635	570	65	713	35	179	815	260	20	960	350	120	143	95	150
MTB-30HWFN1-QRD0	1140	270	775	710	65	933	35	179	1035	260	45	1240	500	120	143	95	150
MTB-36HWFN1-QRD0 MTB-42HWFN1-QRD0 MTB-48HWFN1-QRD0 MTB-55HWFN1-QRD0	1200	300	865	800	80	968	40	204	1094	288	45	1240	500	175	198	155	210

3. Service Space

Ensure enough space required for installation and maintenance.

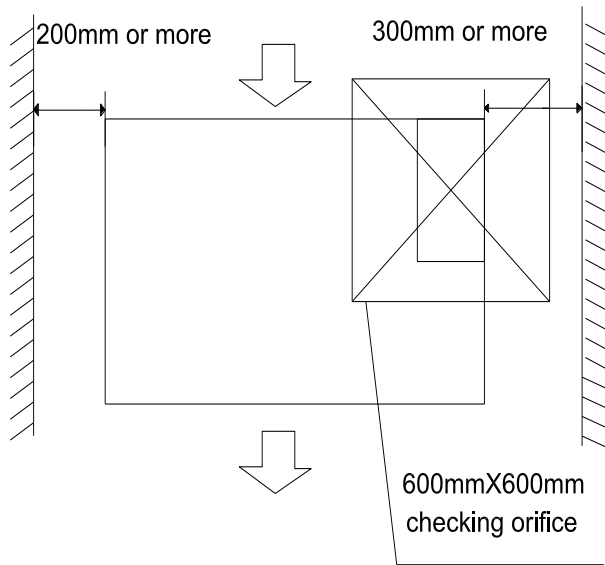

All the indoor units reserve the hole to joint the fresh air pipe. The hole size as following:

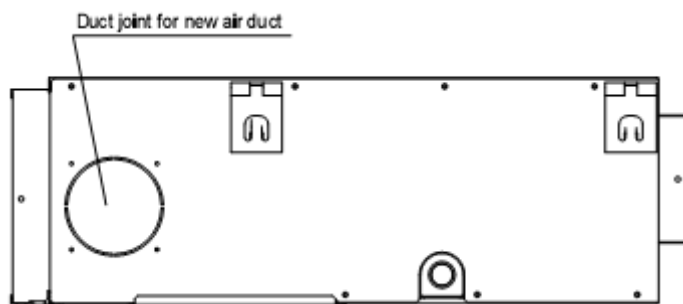

MODLE	
12-24	30-60
<p>Ø90mm</p> <p>80mm</p> <p>80mm</p>	<p>Ø125mm</p> <p>Ø160mm</p>

4. Wiring Diagrams

MTBU-12HWFN1-QRD0W

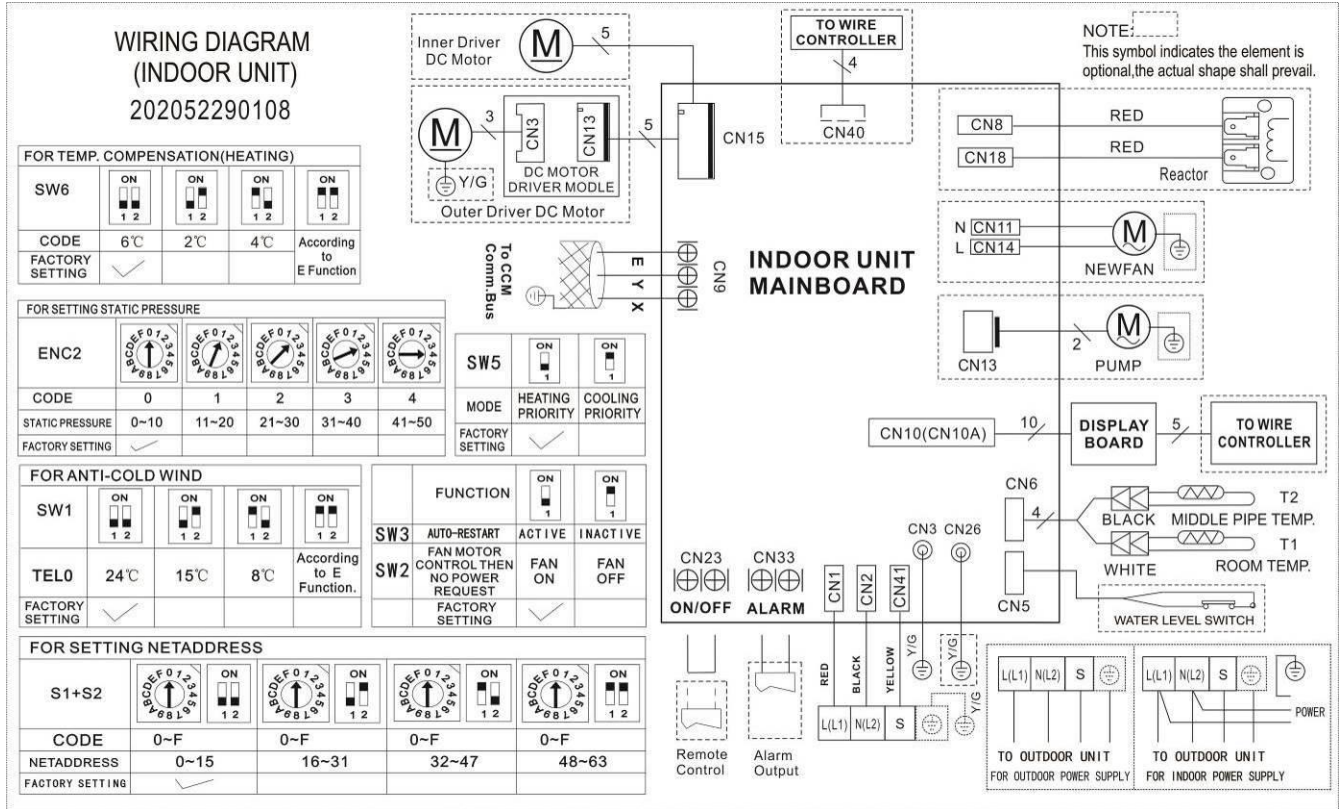

MTB-18HWFN1-QRD0

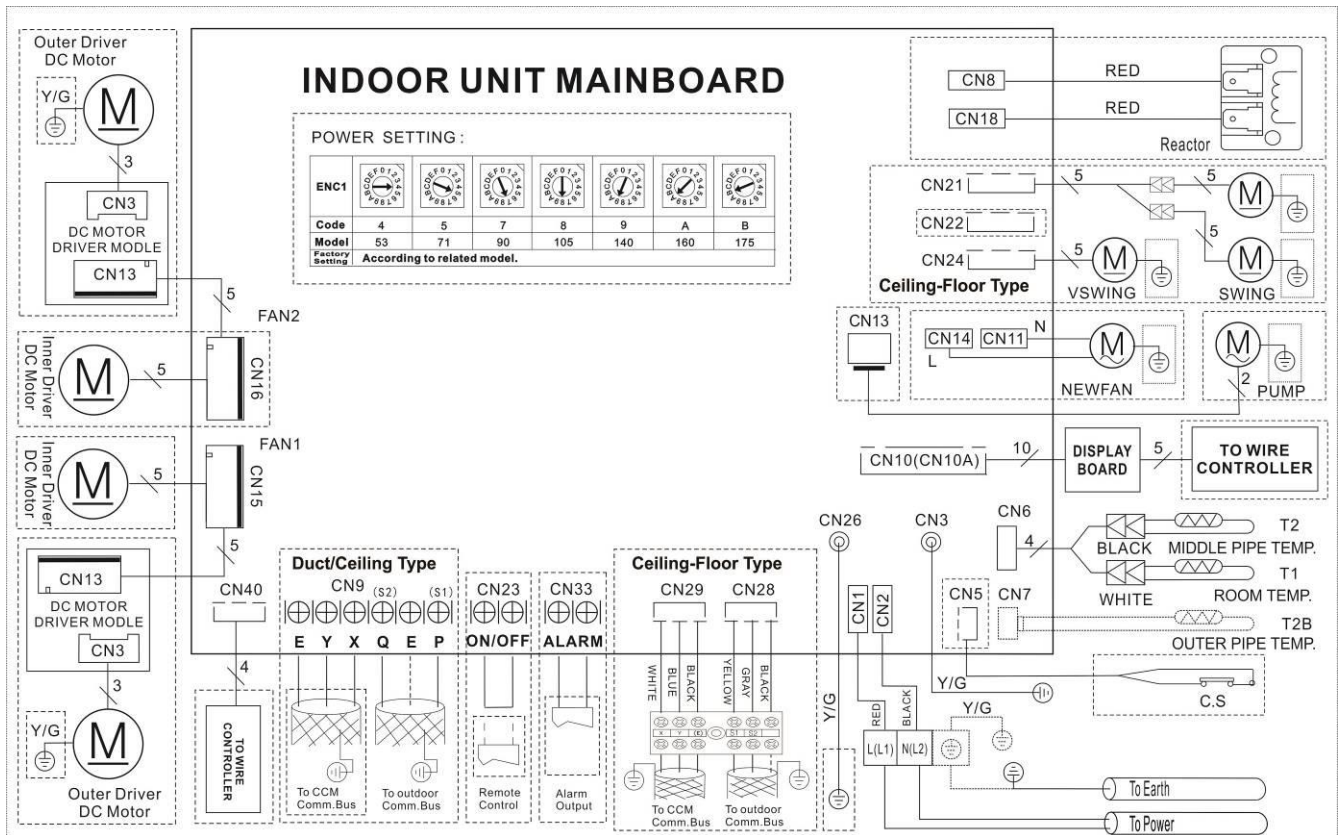

**MTB-24HWFN1-QRD0, MTB-30HWFN1-QRD0, MTB-36HWFN1-QRD0, MTB-42HWFN1-QRD0
MTB-48HWFN1-QRD0, MTB-55HWFN1-QRD0**

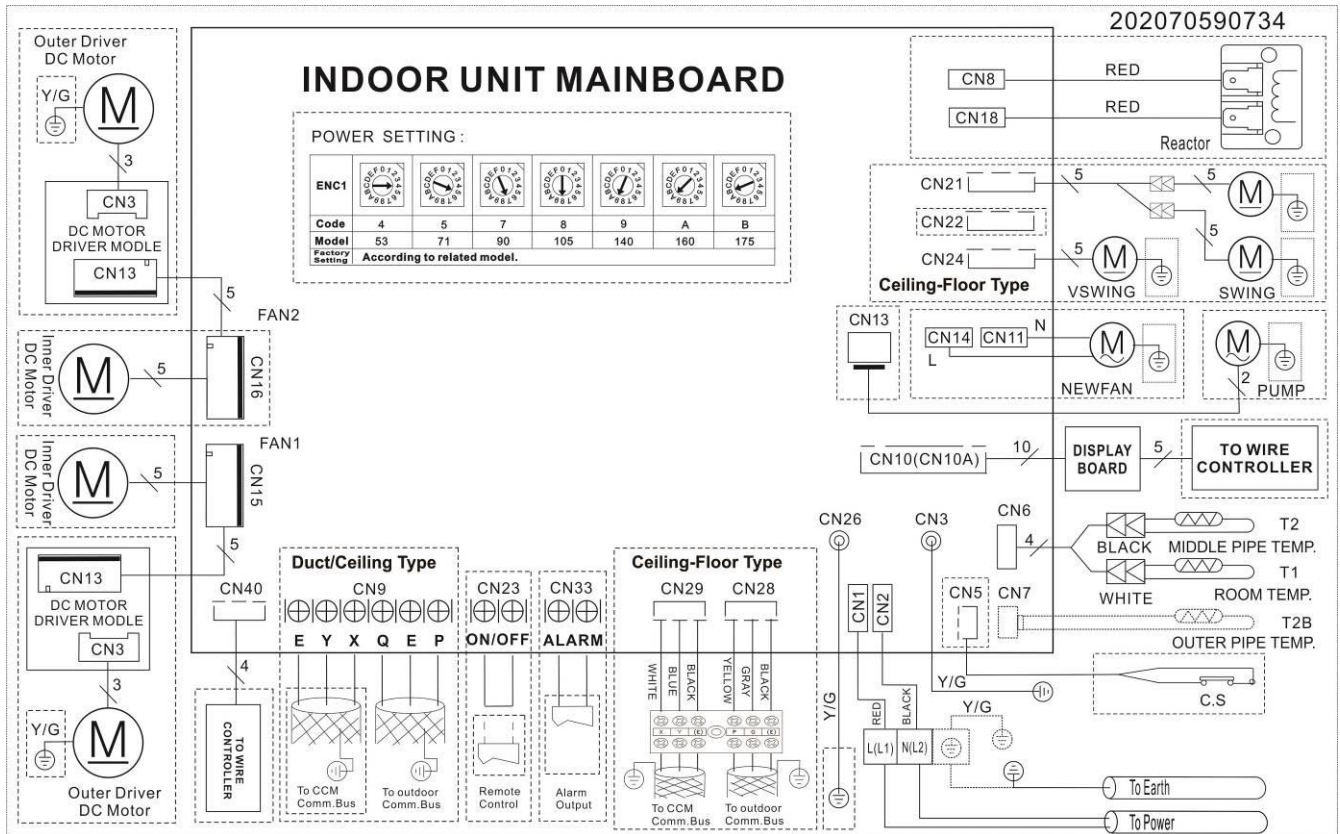

Pre-setting Instructions

FOR SETTING POWER							FOR ANTI-COLD WIND					
ENC1							SW1					
CODE	4	5	7	8	9	A	TELO	24°C	15°C	Fan motor do not stop.	According to the EFunction.	
POWER	≤53	54~71	72~90	91~105	106~140	141~160	FACTORY SETTING	<input checked="" type="checkbox"/>				
FACTORY SETTING	ACCORDING TO RELATED MODEL.											
FOR SETTING NETADDRESS							FOR SETTING FAN MOTOR CONTROL THEN NO POWER REQUEST					
S1+S2							SW2					
CODE	0~F	0~F	0~F	0~F	0~F	0~F	MODE	FAN OFF	FAN ON			
NETADDRESS	0~15	16~31	32~47	48~63			FACTORY SETTING	<input checked="" type="checkbox"/>				
FACTORY SETTING	<input checked="" type="checkbox"/>											
FOR SETTING STATIC PRESSURE							FOR SETTING AUTO-RESTART					
ENC2							SW3					
MODEL (K Btu/h)	CODE	0	1	2	3	4	AUTO-RESTART	ACTIVE	INACTIVE			
	MODEL ≤ 12	0(Pa)	10(Pa)	20(Pa)	30(Pa)	40(Pa)	FACTORY SETTING	<input checked="" type="checkbox"/>				
	12 < MODEL ≤ 24	10(Pa)	25(Pa)	40(Pa)	55(Pa)	70(Pa)						
	24 < MODEL ≤ 60	20(Pa)	35(Pa)	50(Pa)	65(Pa)	80(Pa)						
FACTORY SETTING		<input checked="" type="checkbox"/>										
FOR TEMP. COMPENSATION												
							SW6					
							DUCT TYPE	6°C	2°C	4°C	According to EFunction.	
							FACTORY SETTING	<input checked="" type="checkbox"/>				

FUNCTION SETTING INDICATION

5. Static Pressure MTBU-12HWFN1-QRD0W

High Speed

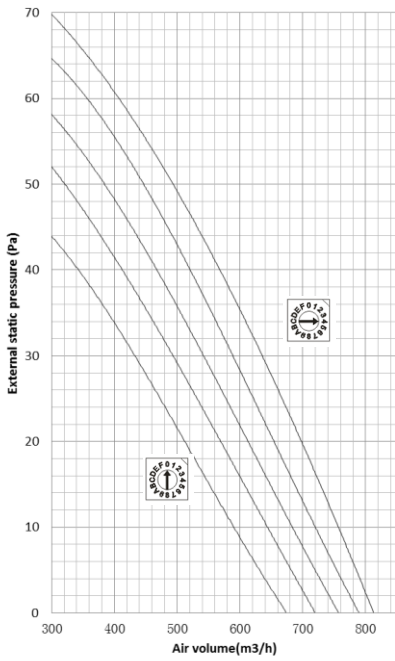

Middle Speed

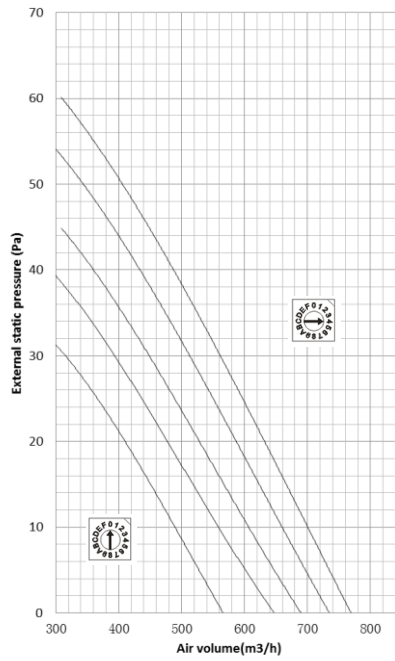

Low Speed

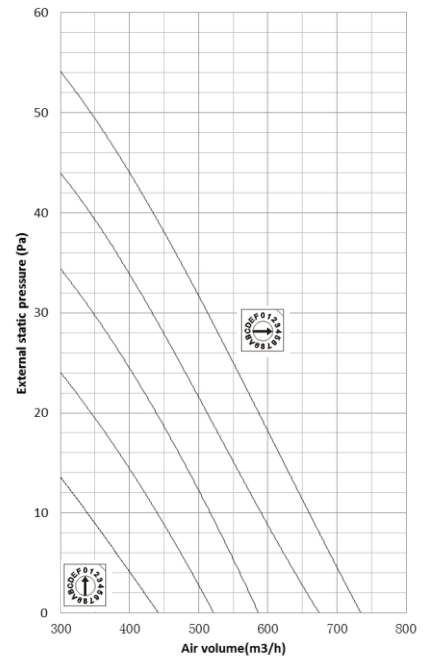

MTB-18HWFN1-QRD0

High Speed

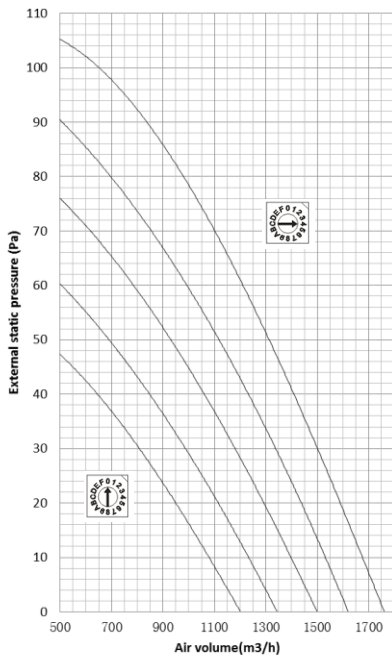

Middle Speed

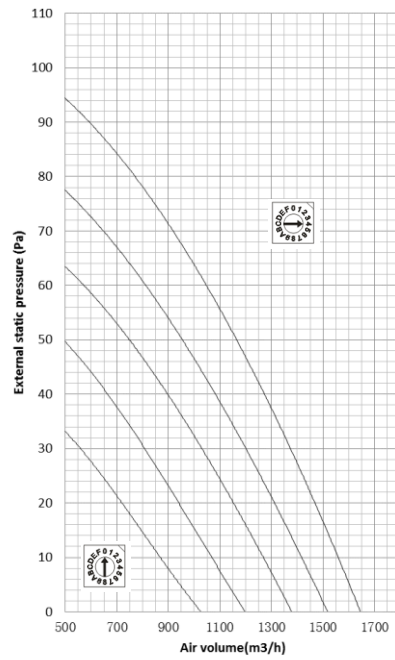

Low Speed

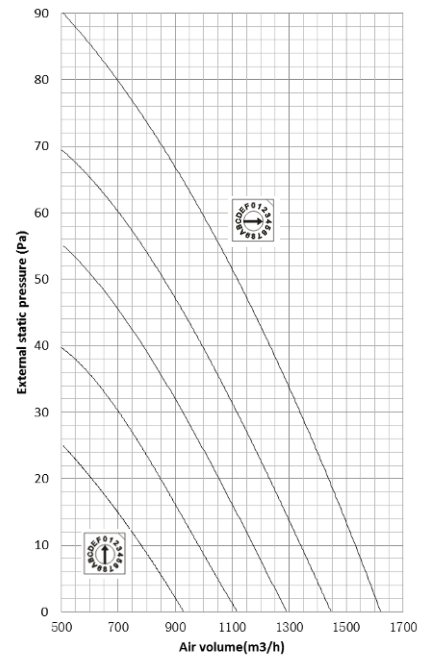

MTB-24HWFN1-QRD0

High Speed

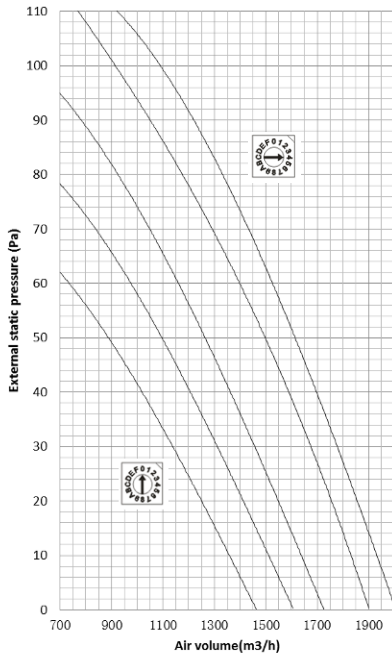

Middle Speed

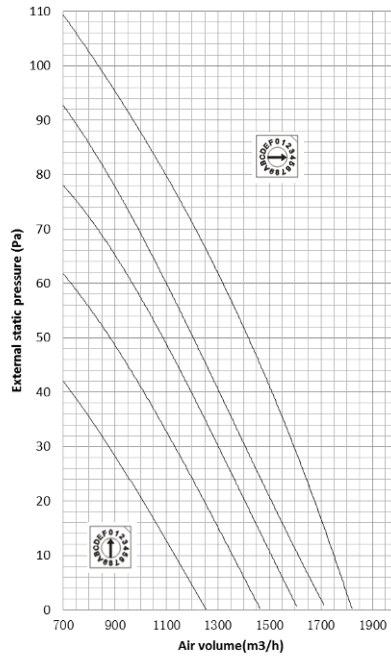

Low Speed

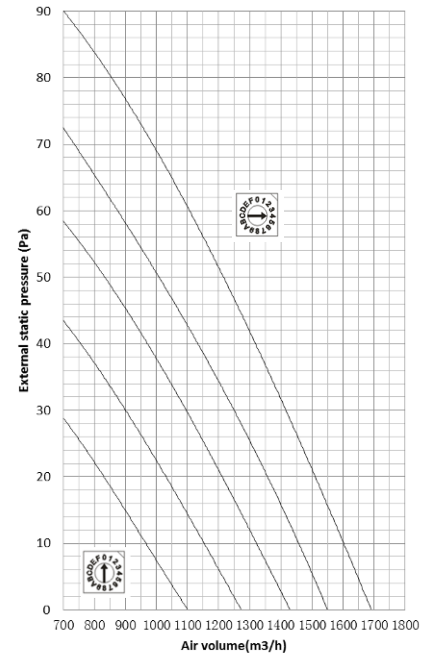

MTB-30HWFN1-QRD0

High Speed

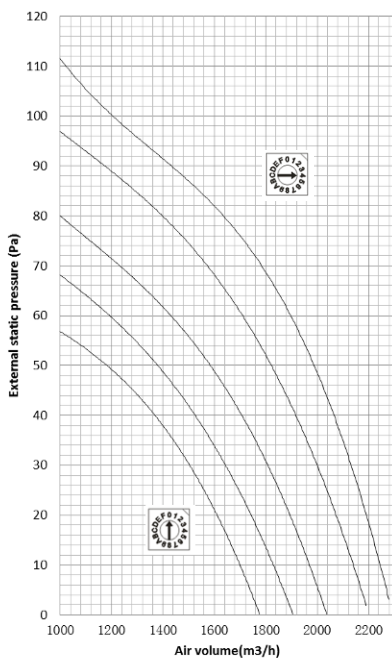

Middle Speed

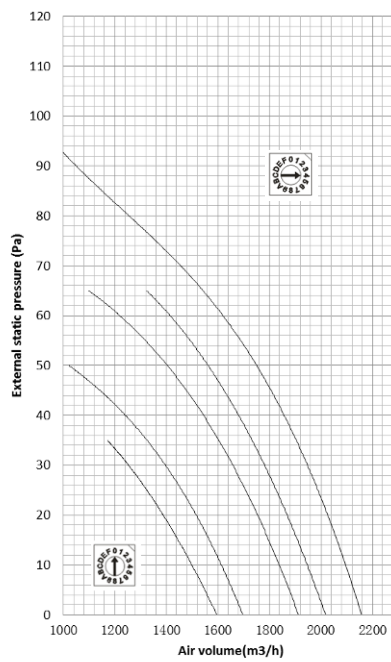

Low Speed

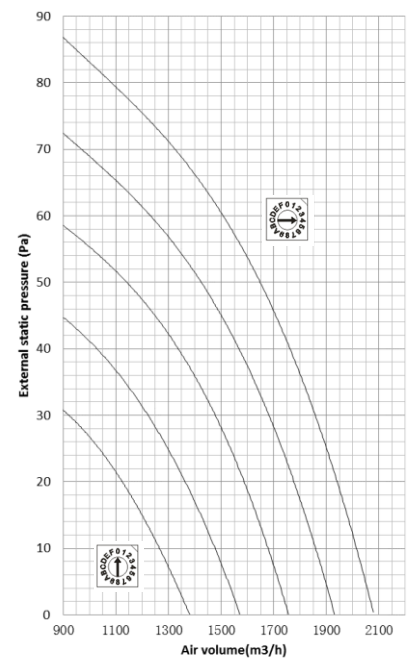

MTB-36HWFN1-QRD0

High Speed

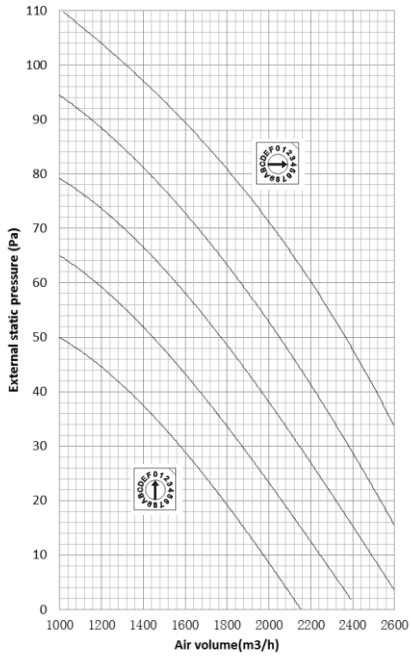

Middle Speed

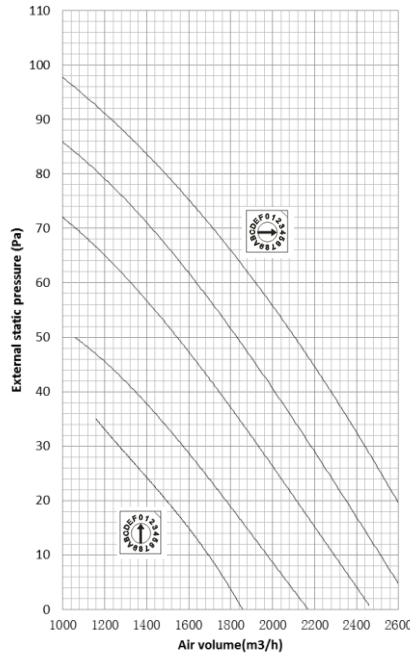

Low Speed

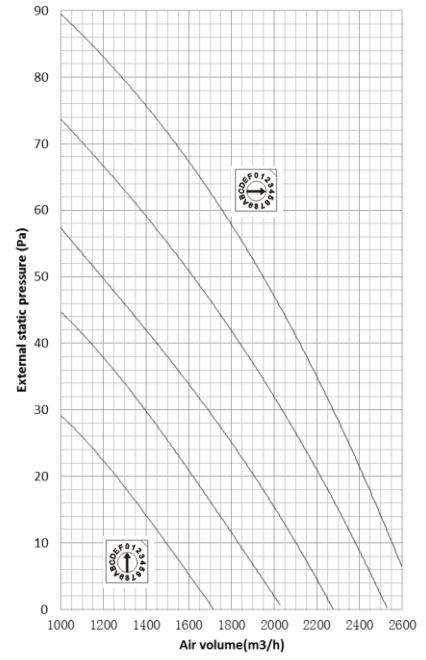

MTB-42HWFN1-QRD0, MTB-48HWFN1-QRD0, MTB-55HWFN1-QRD0

High Speed

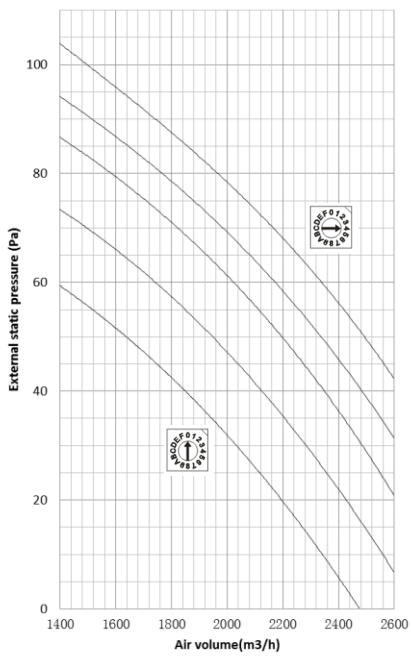

Middle Speed

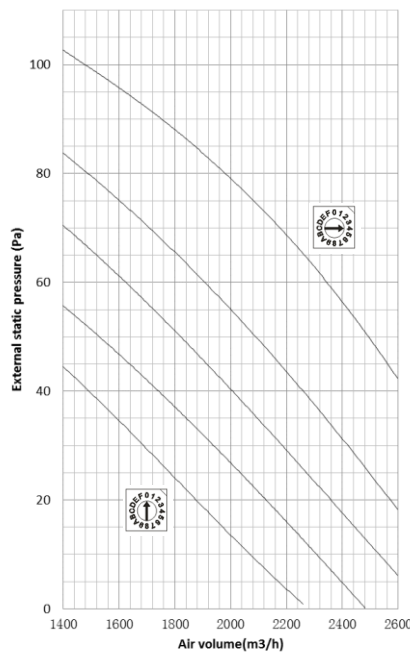

Low Speed

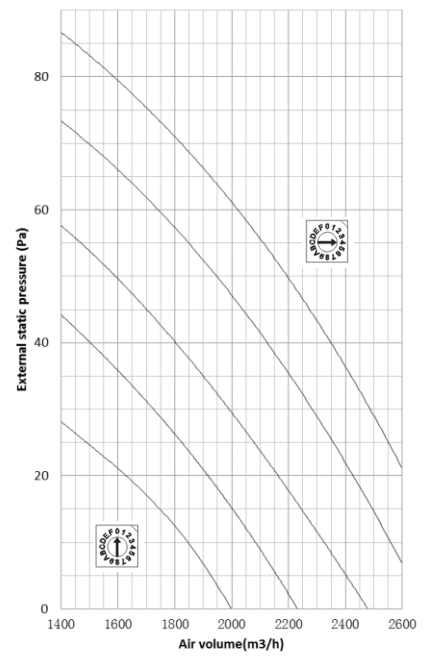

6. Electric Characteristics

Model	Indoor Unit				Power Supply
	Hz	Voltage	Min.	Max.	MFA
MTBU-12HWFN1-QRD0W	50	220-240V	198V	254V	/
MTB-18HWFN1-QRD0	50	220-240V	198V	254V	/
MTB-24HWFN1-QRD0	50	220-240V	198V	254V	/
MTB-30HWFN1-QRD0	50	220-240V	198V	254V	/
MTB-36HWFN1-QRD0	50	220-240V	198V	254V	/
MTB-42HWFN1-QRD0	50	220-240V	198V	254V	/
MTB-48HWFN1-QRD0	50	220-240V	198V	254V	/
MTB-55HWFN1-QRD0	50	220-240V	198V	254V	/

Note:





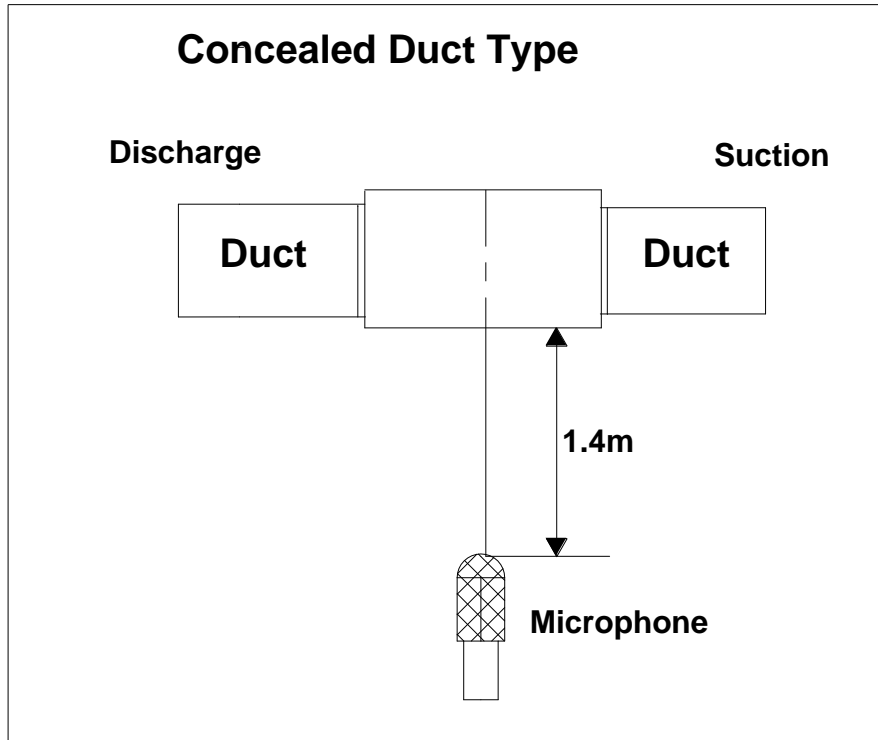



MFA: Max. Fuse Amps. (A)

7. Sound Levels



Model	Sound Power dB(A)	Noise level dB(A)		
		H	M	L
MTBU-12HWFN1-QRD0W	59	42	38	35
MTB-18HWFN1-QRD0	57	44	40	37
MTB-24HWFN1-QRD0	60	44	42	38
MTB-30HWFN1-QRD0	65	53	48	44
MTB-36HWFN1-QRD0	64	46	43	40
MTB-42HWFN1-QRD0	68	49	47	44
MTB-48HWFN1-QRD0	68	50	47	44
MTB-55HWFN1-QRD0	69	50	47	45

8. Accessories

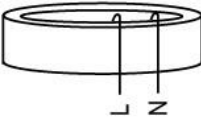
	Name	Shape	Quantity
Tubing & Fittings	Soundproof / insulation sheath		2
	Binding tape		1
	Seal sponge		1
Drainpipe Fittings (for cooling & heating)	Drain joint		1
	Seal ring		1
Wired controller & Its Frame	Wired controller		1
Others	Owner's manual		1
	Installation manual		1
EMS & It's fitting	Magnetic ring (twist the electric wires L and N around it to five circles)		1

9. The Specification of Power

Model(Btu/h)		12000	18000-24000	30000	36000	36000
POWER	Phase	1-phase	1-phase	1-phase	1-phase	3-phase
	Frequency and Voltage	220-240V, 50Hz	220-240V, 50Hz	220-240V, 50Hz	220-240V, 50Hz	380-420V, 50Hz
	POWER WIRING (mm ²)	3×2.5	3×2.5	3×2.5	3×4.0	5×2.5
CIRCUIT BREAKER/Fuse (A)		20/16	30/20	40/30	40/30	30/20
Indoor/Outdoor Connecting Wiring(Weak Electric Signal) (mm ²)		————	2×0.2	2×0.2	2×0.2	2×0.2
Indoor/Outdoor Connecting Wiring(Strong Electric Signal) (mm ²)		4×1.0	3×1.0	3×1.0	3×1.0	3×1.0

Model(Btu/h)		42000~48000	42000-60000
POWER	Phase	1-phase	3-phase
	Frequency and Voltage	220-240V, 50Hz	380-415V, 50Hz
	Power Wiring (mm ²)	3×4.0	5×2.5
Circuit Breaker/Fuse(A)		40/35	30/25
Indoor/Outdoor Connecting Wiring(Weak Electric Signal) (mm ²)		2×0.2	2×0.2
Indoor/Outdoor Connecting Wiring(Strong Electric Signal) (mm ²)		3×1.0	3×1.0

10. Field Wiring

MTBU-12HWFN1-QRD0W

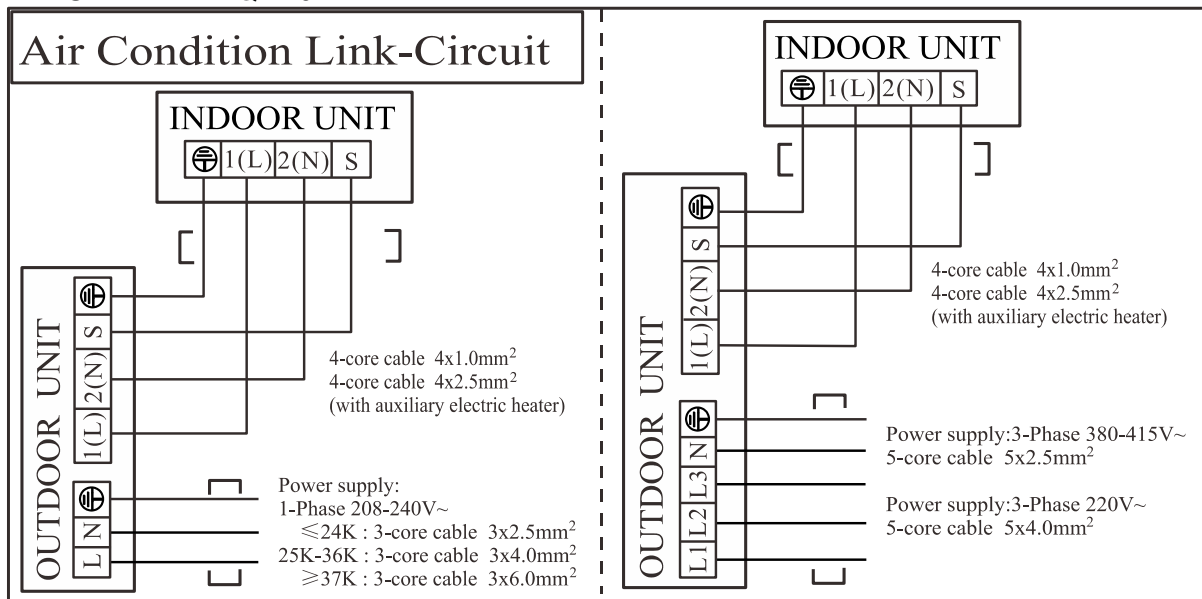

MTB-18HWFN1-QRD0, MTB-24HWFN1-QRD0, MTB-30HWDN1-QRD0, MTB-36HWFN1-QRD0
MTB-42HWFN1-QRD0, MTB-48HWFN1-QRD0, MTB-55HWFN1-QRD0

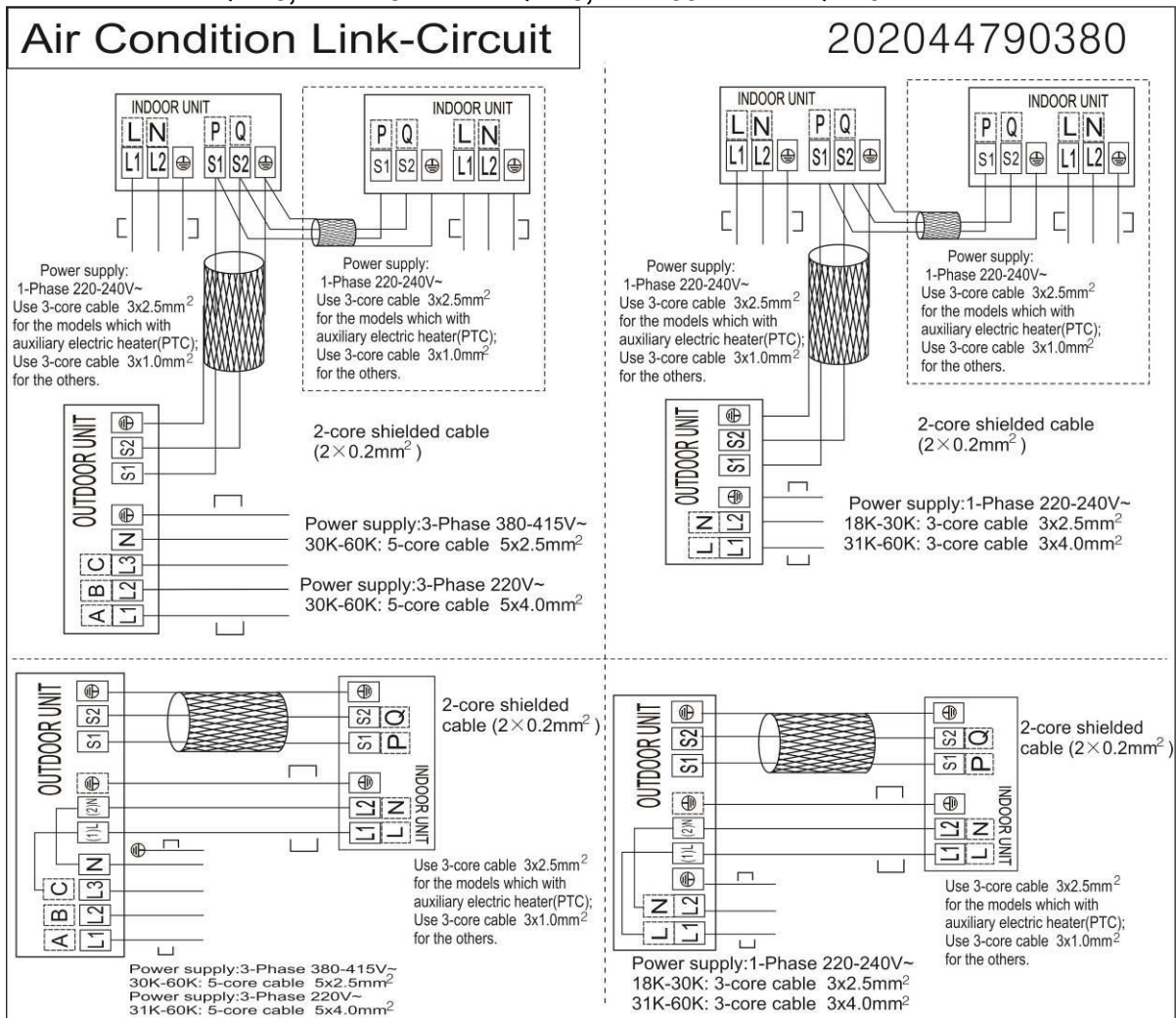

Ceiling & Floor Type

1. Features.....	39
2. Dimensions.....	40
3. Service Space	41
4. Wiring Diagrams.....	42
5. Electric Characteristics	43
6. Sound Levels	43
7. Air Velocity and Temperature Distributions (Reference Data).....	44
8. Accessories	50
9. The Specification of Power	50
10. Field Wiring	51

1. Features

1.1. New design, more modern and elegant appearance.



1.2. Convenient installation

- The ceiling type can be easily installed into a corner of the ceiling even if the ceiling is very narrow
- It is especially useful when installation of an air conditioner in the center of the ceiling is impossible due to a structure such as one lighting.

1.3. Two direction auto swing (vertical & horizontal) and wide angle air flow,

- Air flow directional control minimizes the air resistance and produces wilder air flow to vertical direction.
- The range of horizontal air discharge is widened which secures wider air flow distribution to provide more comfortable air circulation no matter where the unit is set up

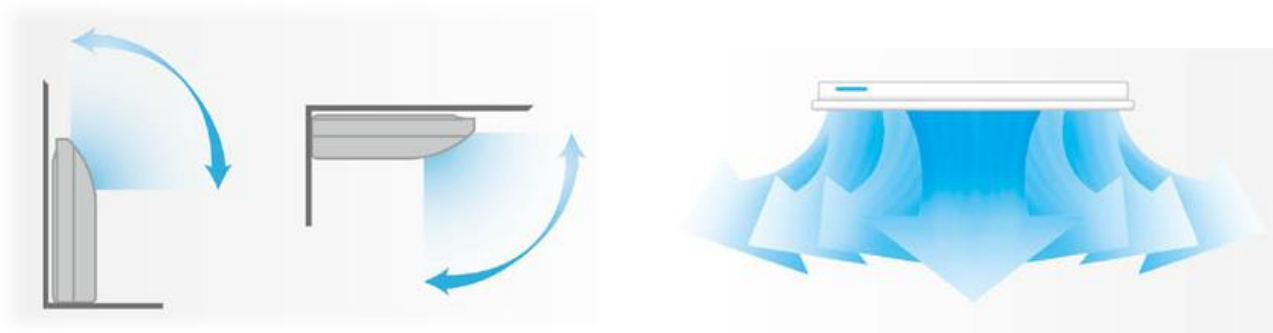

1.4. Three level fan speed, more humanism design, meets different air-supply requirement.

1.5. New foam drain pan with plastic-spraying inner surface



1.6. Easy operation.

1.7. Remote control and optional wired control method.

2. Dimensions

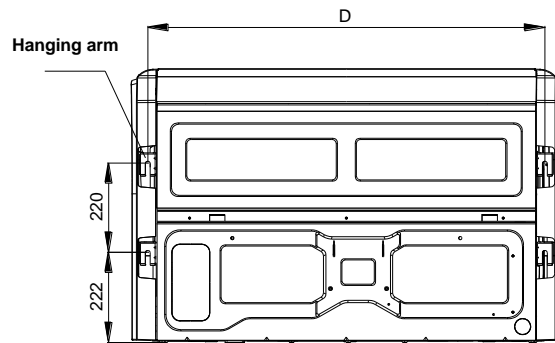
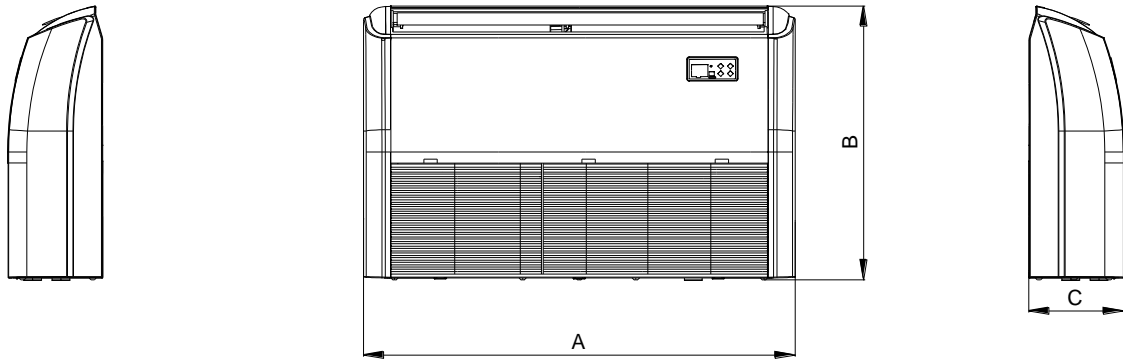
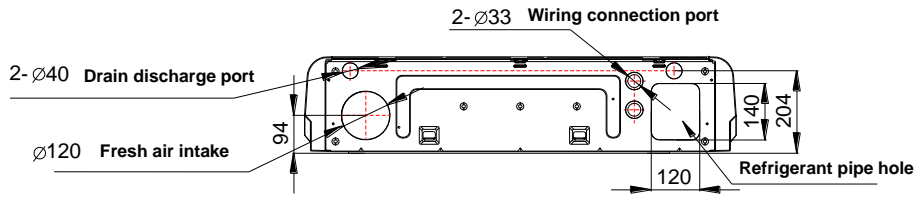

Capacity (KBtu/h)	A	B	C	D
18/24	1068	675	235	983
30	1285	675	235	1200
36/42/48/55	1650	675	235	1565

3. Service Space

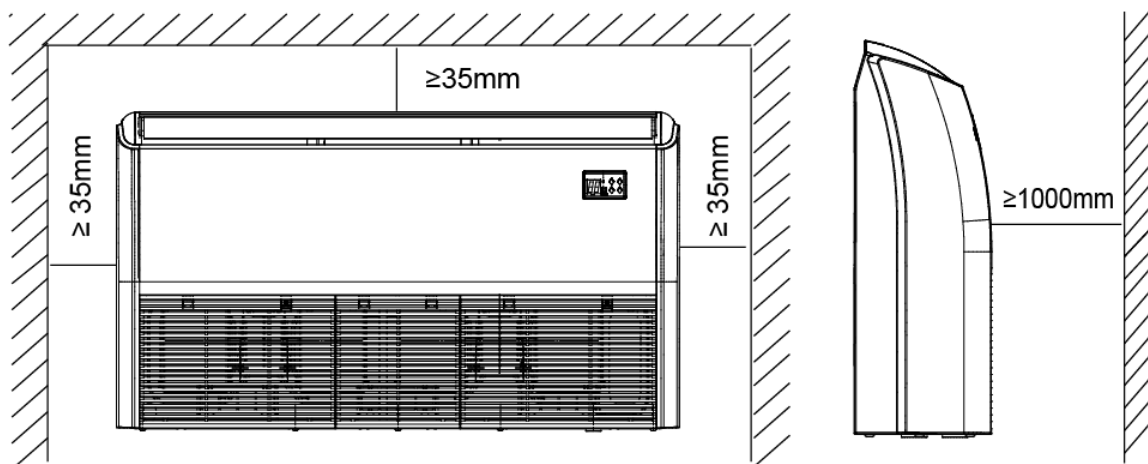

4. Wiring Diagrams

MUE-18HRFN1-QRD0, MUE-24HRFN1-QRD0, MUE-30HRFN1-QRD0, MUE-36HRFN1-QRD0

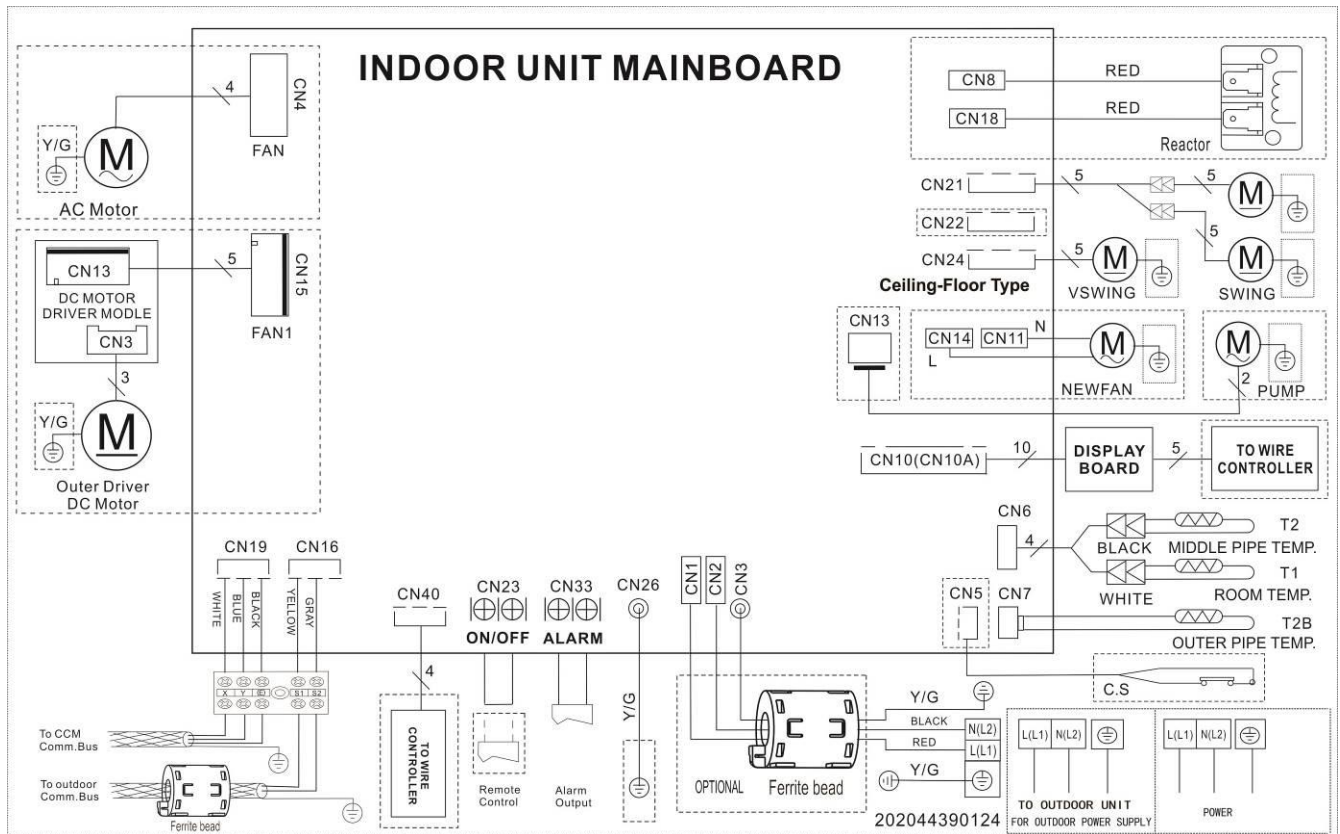

MUE-42HRFN1-QRD0, MUE-48HRFN1-QRD0, MUE-55HRFN1-QRD0

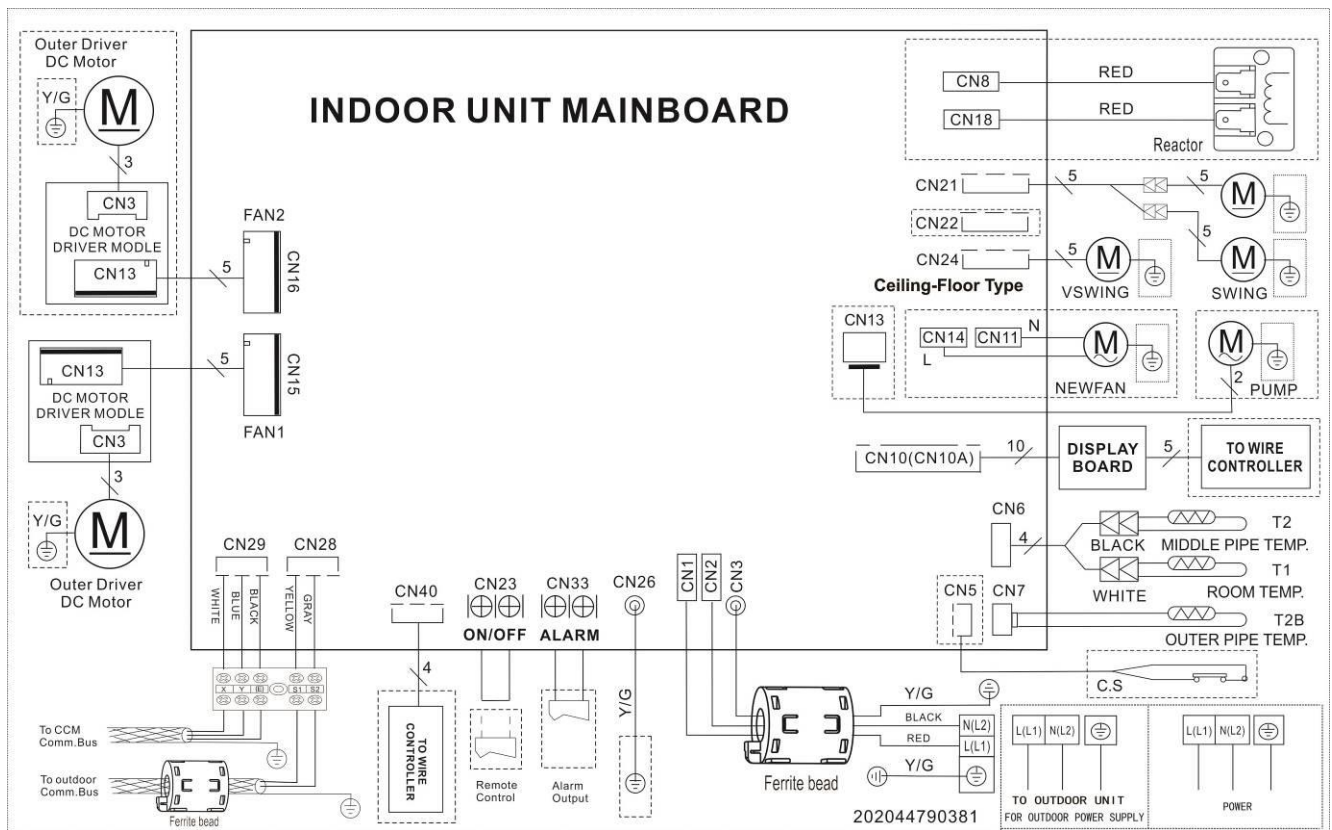

5. Electric Characteristics

Model	Indoor Units				Power Supply
	Hz	Voltage	Min.	Max.	MFA
MUE-18HRFN1-QRD0	50	220-240V	198V	254V	/
MUE-24HRFN1-QRD0	50	220-240V	198V	254V	/
MUE-30HRFN1-QRD0	50	220-240V	198V	254V	/
MUE-36HRFN1-QRD0	50	220-240V	198V	254V	/
MUE-42HRFN1-QRD0	50	220-240V	198V	254V	/
MUE-48HRFN1-QRD0	50	220-240V	198V	254V	/
MUE-55HRFN1-QRD0	50	220-240V	198V	254V	/

Note:

MFA: Max. Fuse Amps. (A)

6. Sound Levels

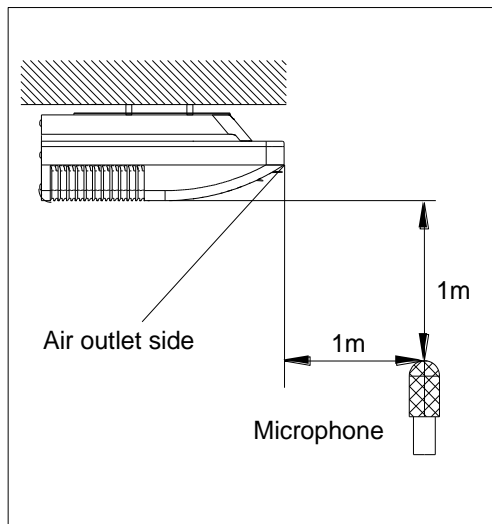

Ceiling

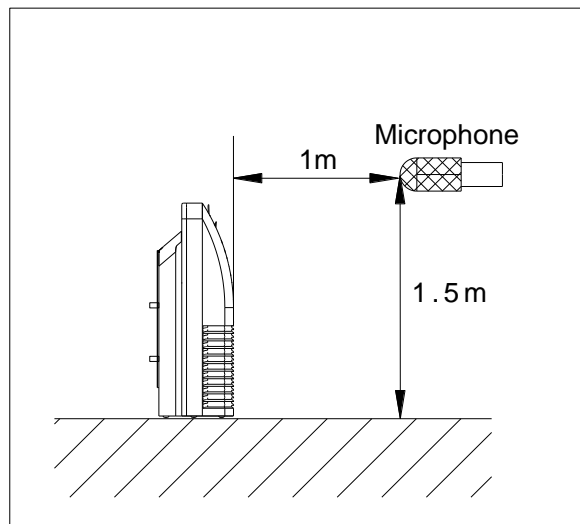

Floor

Model	Sound Power dB (A)	Noise level dB(A)		
		H	M	L
MUE-18HRFN1-QRD0	56	44	39	34
MUE-24HRFN1-QRD0	64	53	48	42
MUE-30HRFN1-QRD0	65	54	49	44
MUE-36HRFN1-QRD0	65	56	53	50
MUE-42HRFN1-QRD0	68	56	48	41
MUE-48HRFN1-QRD0	68	56	48	41
MUE-55HRFN1-QRD0	70	55	50	45

7. Air Velocity and Temperature Distributions (Reference Data)

Model: MUE-18HRFN1-QRD0, MUE-24HRFN1-QRD0

Ceiling installation:

Discharge angle 17°

Cooling airflow velocity distribution

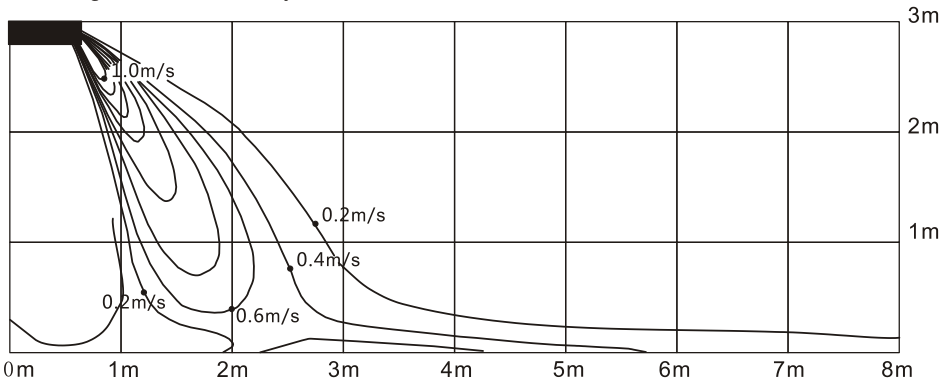

Cooling temperature distribution

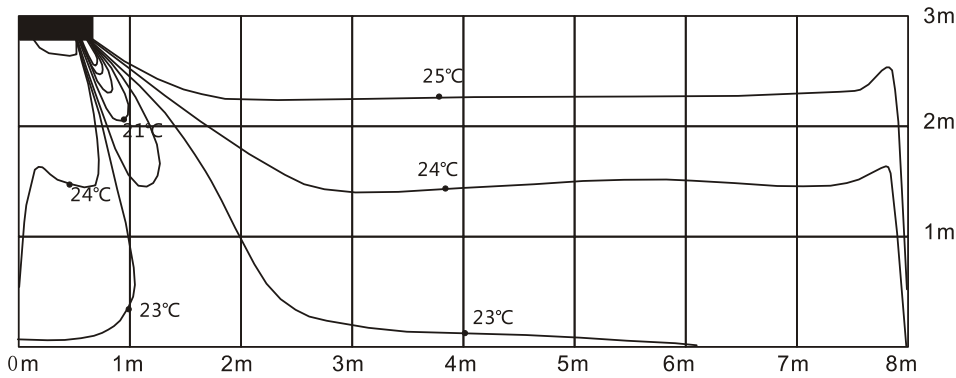

Discharge angle 50°

Heating airflow velocity distribution

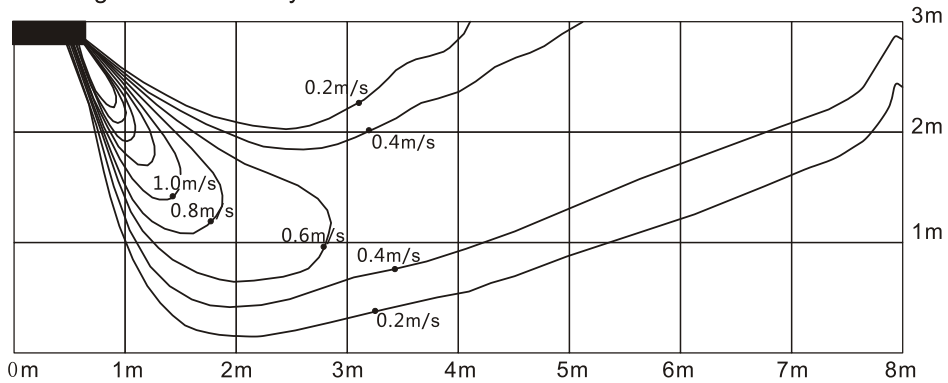

Heating temperature distribution

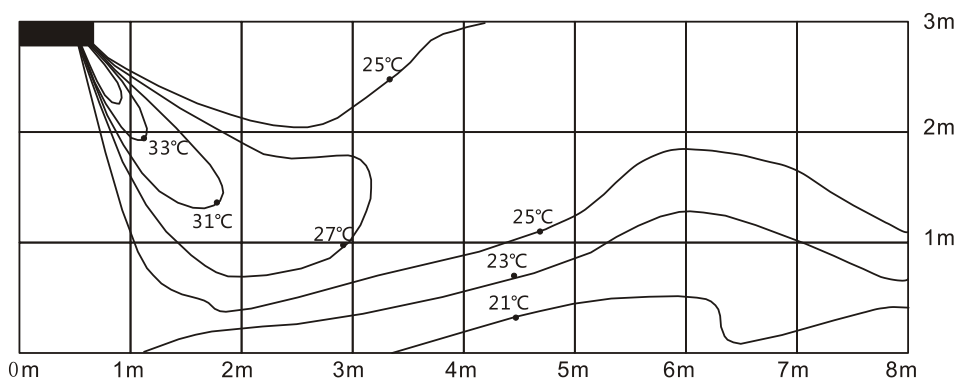

Floor installation:

Discharge angle 17°

Cooling airflow velocity distribution

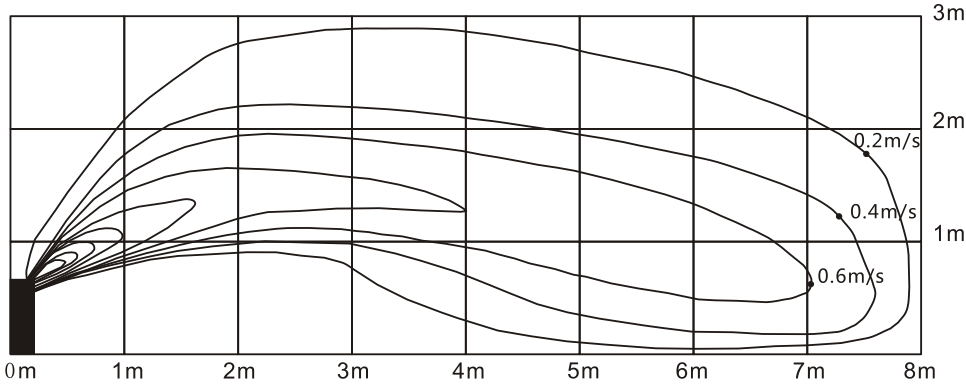

Cooling temperature distribution

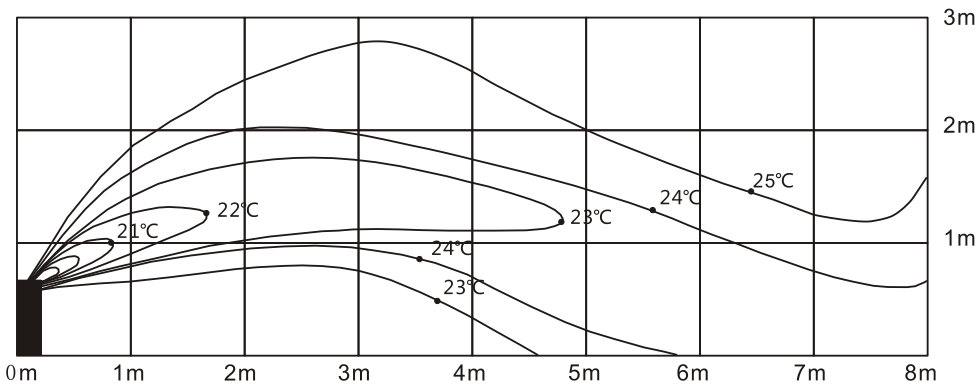

Discharge angle 50°

Heating airflow velocity distribution

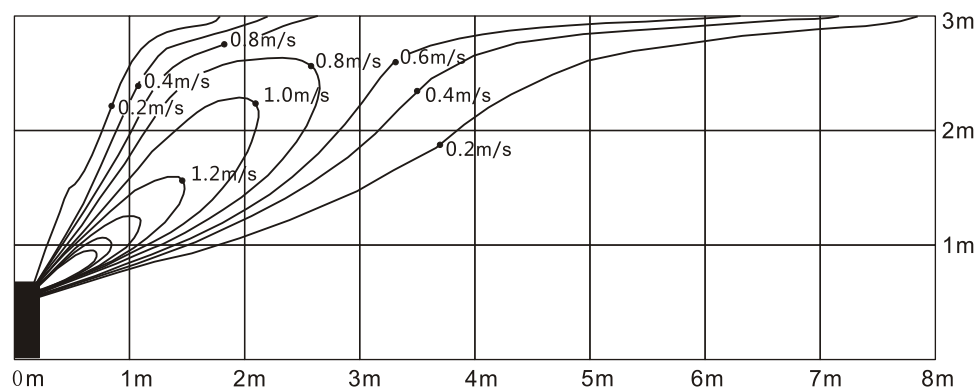

Heating temperature distribution

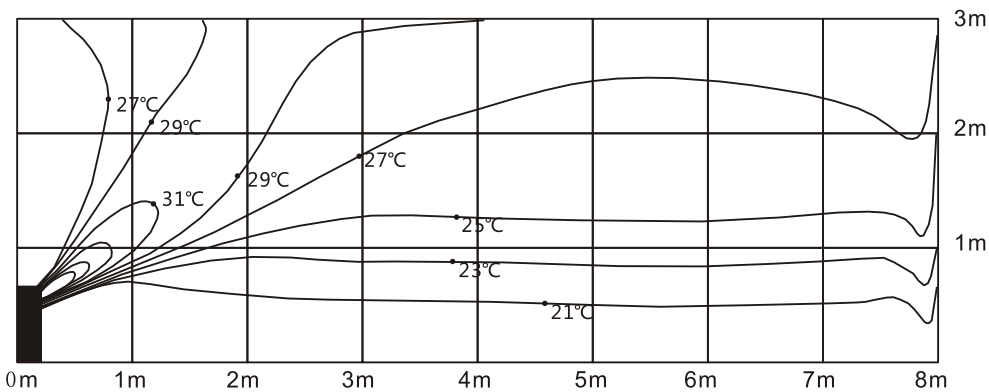

Model: MUE-30HRFN1-QRD0, MUE-36HRFN1-QRD0

Ceiling installation:

Discharge angle 17°

Cooling airflow velocity distribution

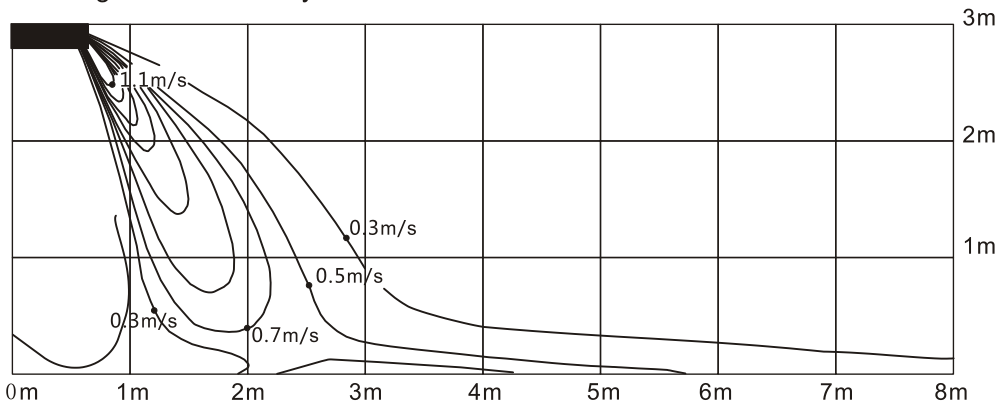

Cooling temperature distribution

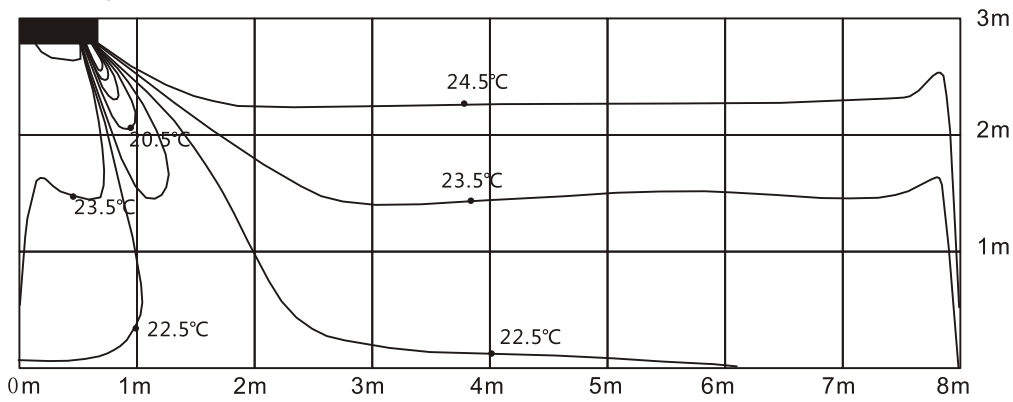

Discharge angle 50°

Heating airflow velocity distribution

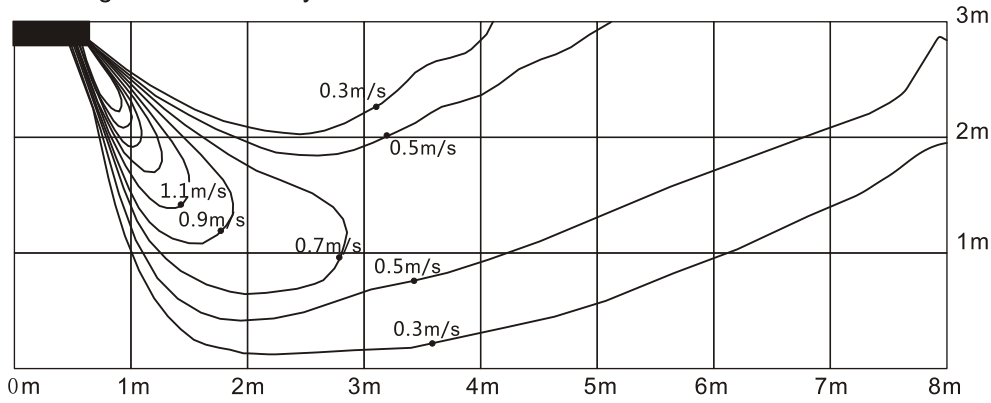

Heating temperature distribution

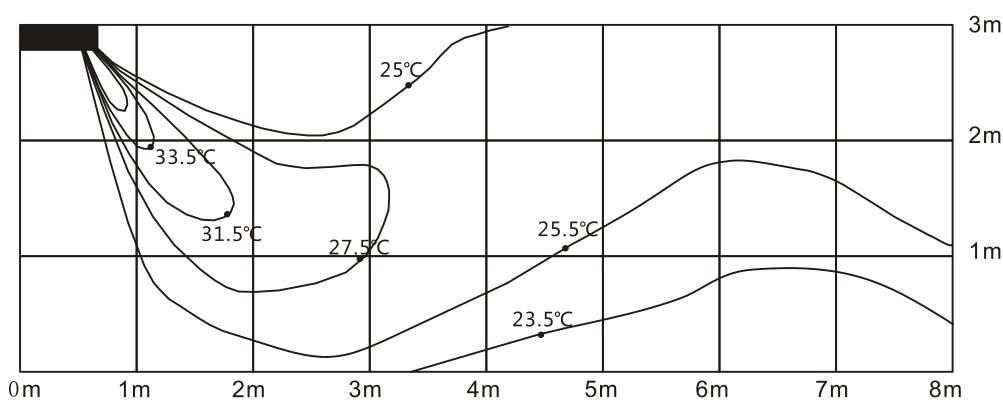

Floor installation:

Discharge angle 17°

Cooling airflow velocity distribution

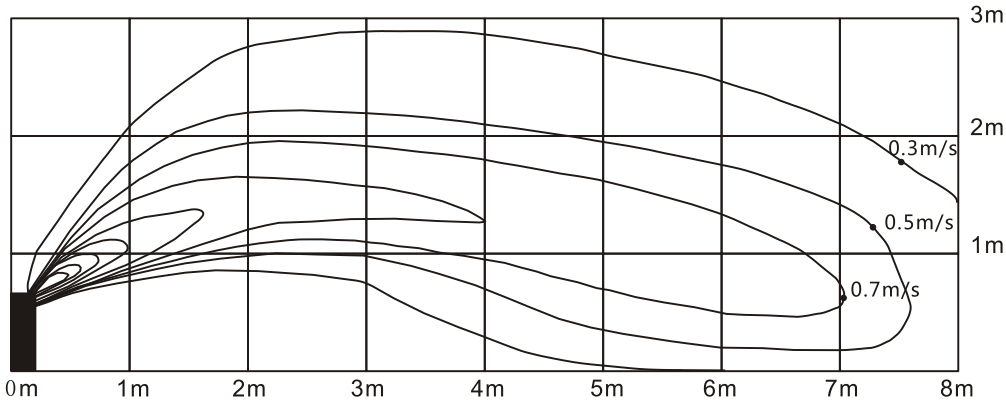

Cooling temperature distribution

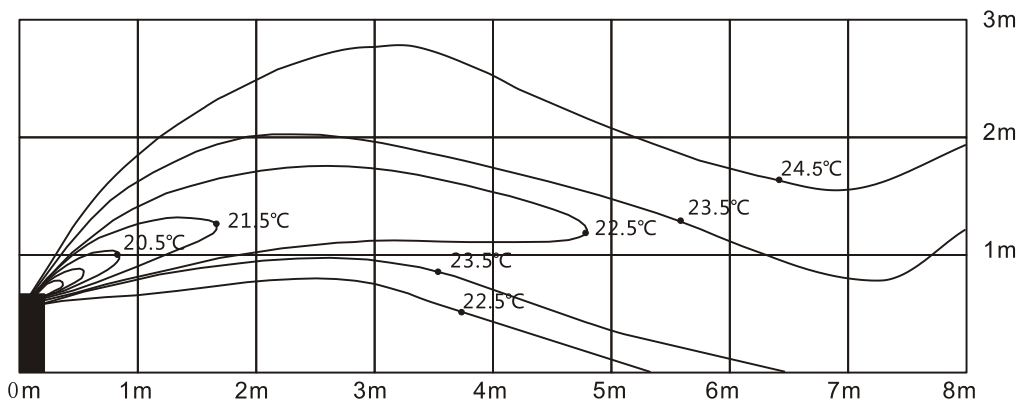

Discharge angle 50°

Heating airflow velocity distribution

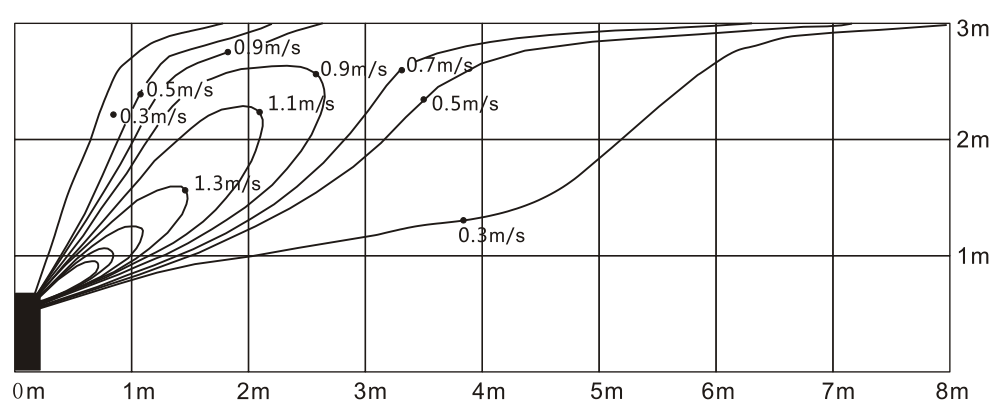

Heating temperature distribution

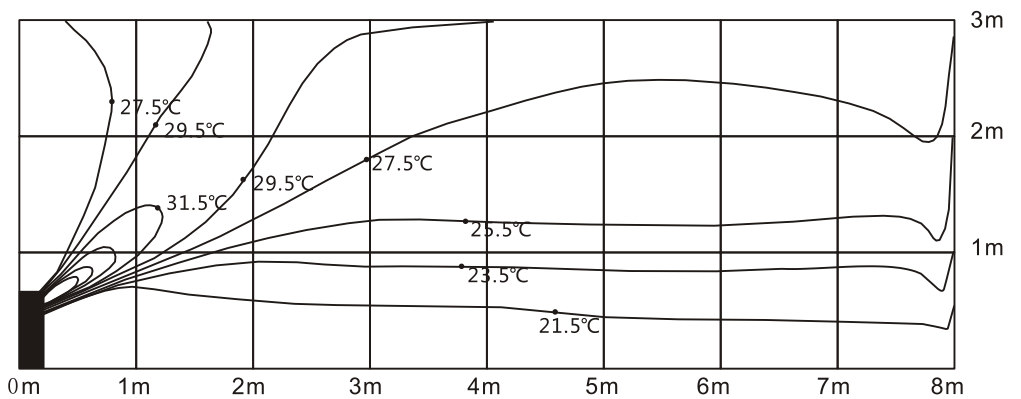

Model: MUE-42HRFN1-QRD0, MUE-48HRFN1-QRD0, MUE-55HRFN1-QRD0

Ceiling installation:

Discharge angle 17°

Cooling airflow velocity distribution

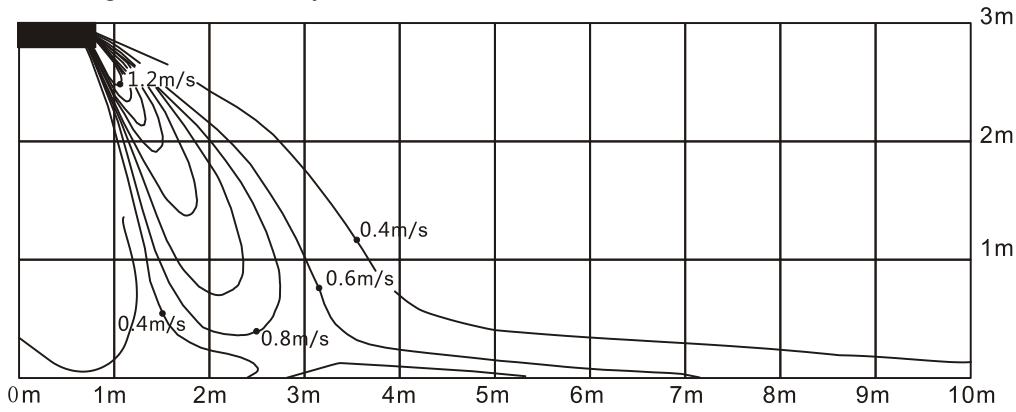

Cooling temperature distribution

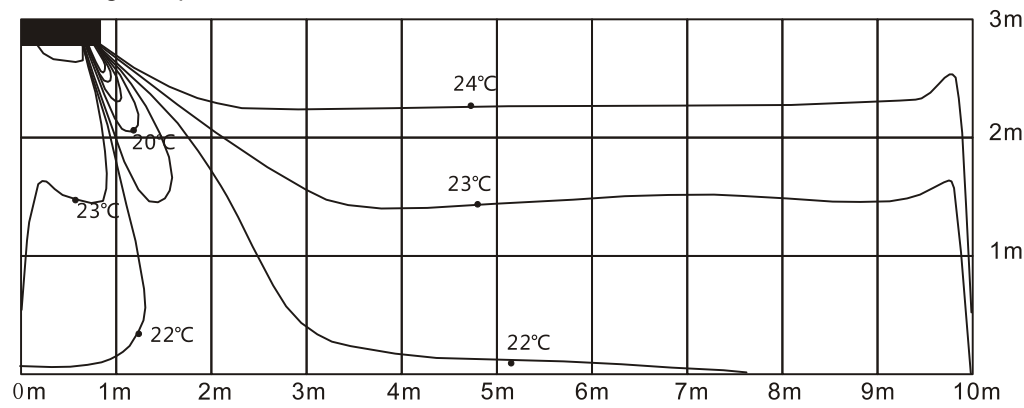

Discharge angle 50°

Heating airflow velocity distribution

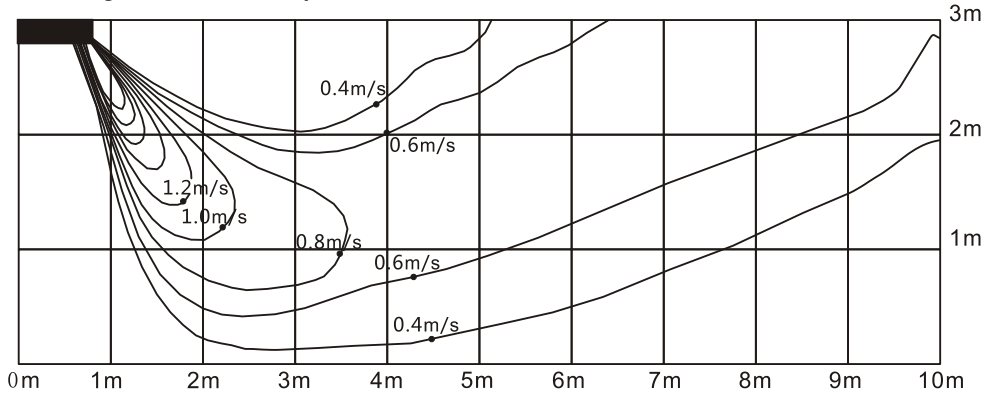

Heating temperature distribution

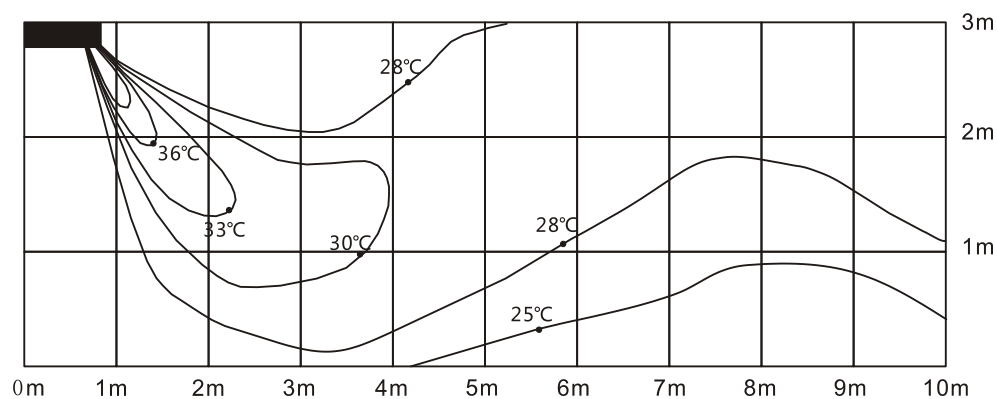

Floor installation:

Discharge angle 17°

Cooling airflow velocity distribution

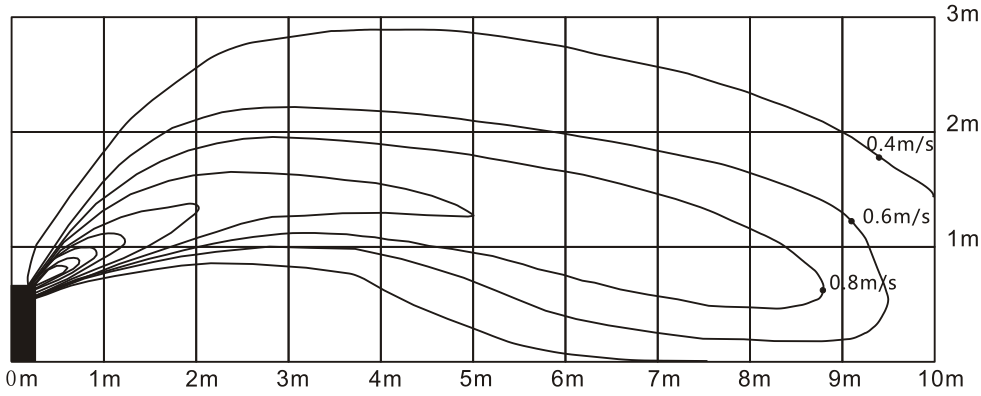

Cooling temperature distribution

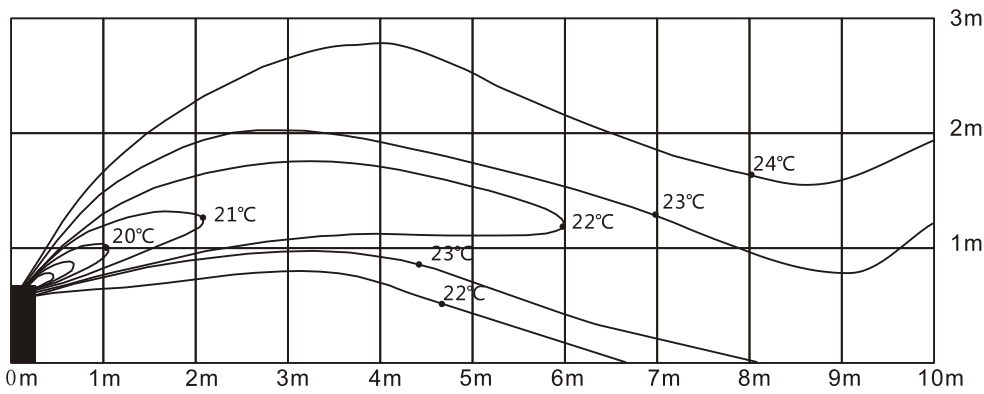

Discharge angle 50°



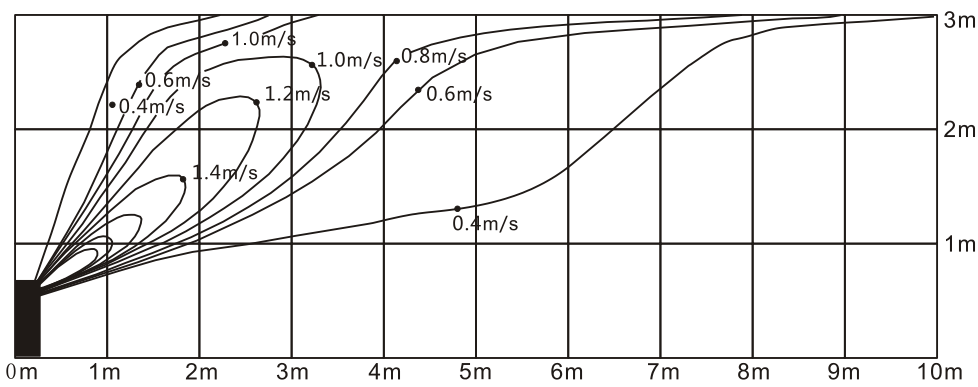

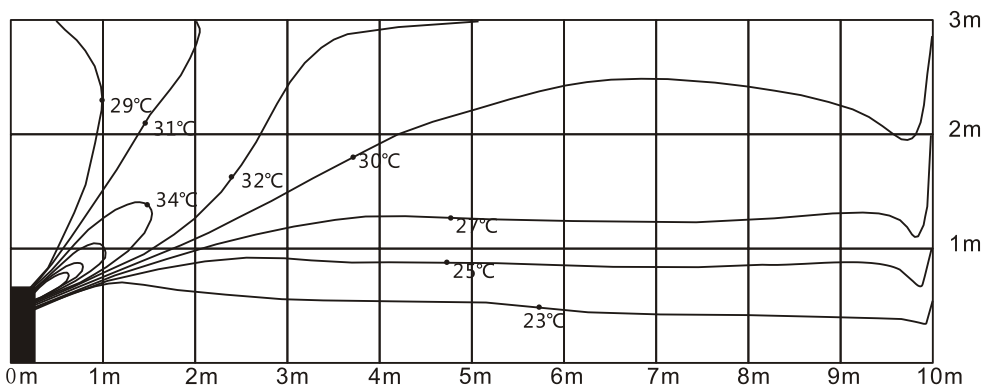

Heating airflow velocity distribution



Heating temperature distribution



8. Accessories

	Name	Shape	Quantity
Remote controller & Its holder(The product you have might not be provided the following accessories)	1. Remote controller		1
	2. Remote controller holder		1
	3. Mounting screw (ST2.9x10-C-H)		2
	4. Alkaline dry batteries (AM4)		2
Others	5. Owner's manual		1
	6. Installation manual		1
	7. Remote controller manual		1

9. The Specification of Power

Model(Btu/h)		18000-24000	30000	36000	36000
POWER	Phase	1-phase	1-phase	1-phase	3-phase
	Frequency and Voltage	220-240V, 50Hz	220-240V, 50Hz	220-240V, 50Hz	380-420V, 50Hz
	POWER WIRING (mm ²)	3x2.5	3x2.5	3x4.0	5x2.5
CIRCUIT BREAKER/Fuse (A)		30/20	40/30	40/30	30/20
Indoor/Outdoor Connecting Wiring (Weak Electric Signal) (mm ²)	Wiring	2x0.2	2x0.2	2x0.2	2x0.2
Indoor/Outdoor Connecting Wiring (Strong Electric Signal) (mm ²)	Wiring	3x1.0	3x1.0	3x1.0	3x1.0

Model(Btu/h)		42000~48000	42000~60000
POWER	Phase	1-phase	3-phase
	Frequency and Voltage	220-240V, 50Hz	380-415V, 50Hz
	Power Wiring (mm ²)	3x4.0	5x2.5
Circuit Breaker/Fuse (A)		40/35	30/25
Indoor/Outdoor Connecting Wiring(Weak Electric Signal) (mm ²)		2x0.2	2x0.2
Indoor/Outdoor Connecting Wiring(Strong Electric Signal) (mm ²)		3x1.0	3x1.0

10. Field Wiring

Air Condition Link-Circuit

202044790380

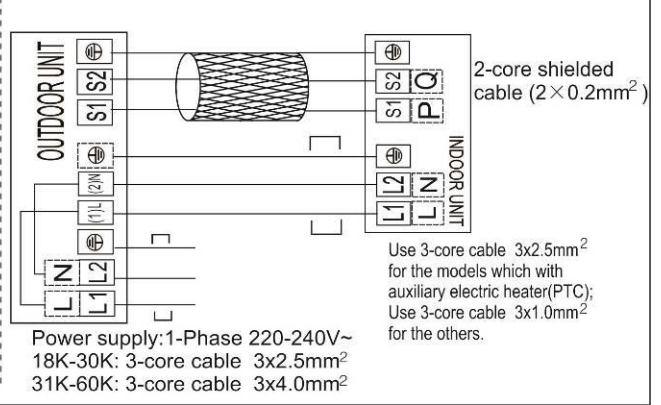
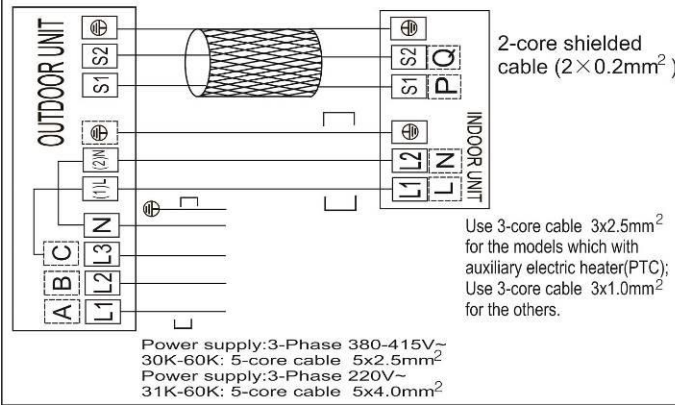
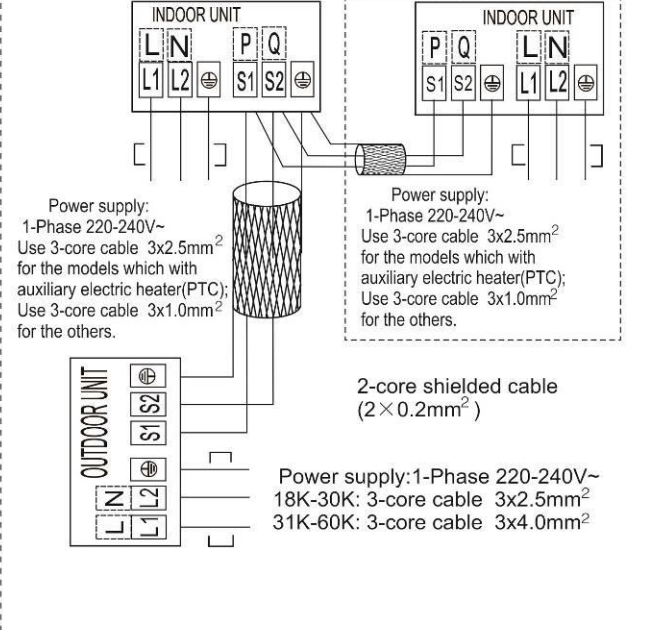
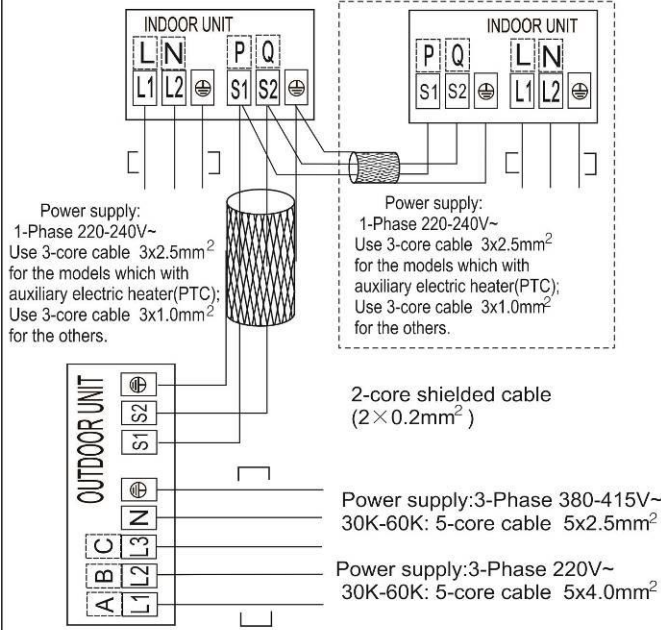

Four-way Cassette Type (Compact)

1. Features	53
2. Dimensions	54
3. Service Space	55
4. Wiring Diagrams.....	56
5. Air Velocity and Temperature Distributions (Reference Data)	57
6. Electric Characteristics	58
7. Sound Levels	58
8. Accessories	59
9. The Specification of Power.....	59
10. Field Wiring.....	60

1. Features

1.1 New panel

- 360°surrounding air outlet design, affords comfortable feeling



1.2 Compact design

- The body size is 570×260×570mm, it's just smaller than the ceiling board, so it's very easy for installation and will not damage the decoration. The panel size is 647×50×647mm.
- The hooks are designed in the four corners of the body, which can save installation space.



1.3 Electric control box built-in design

- The E-box is simply and safely built inside the indoor unit. It's convenient for installation and maintenance. Can check the control part easily, you only need to open the air return grille.



1.4 Air passage function

- Reserves the space for air outlet from the side of indoor unit; It's availed to connect air duct from the two sides to the nearby small rooms.

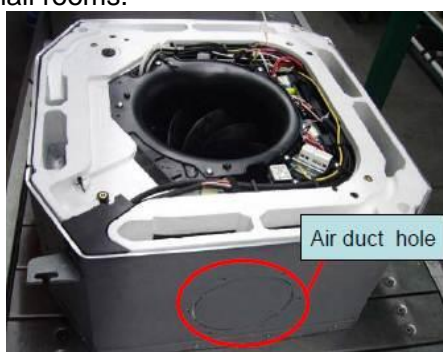

2. Dimensions

MCA3U-12HRFN1-QRD0W, MCA3-18HRFN1-QRD0

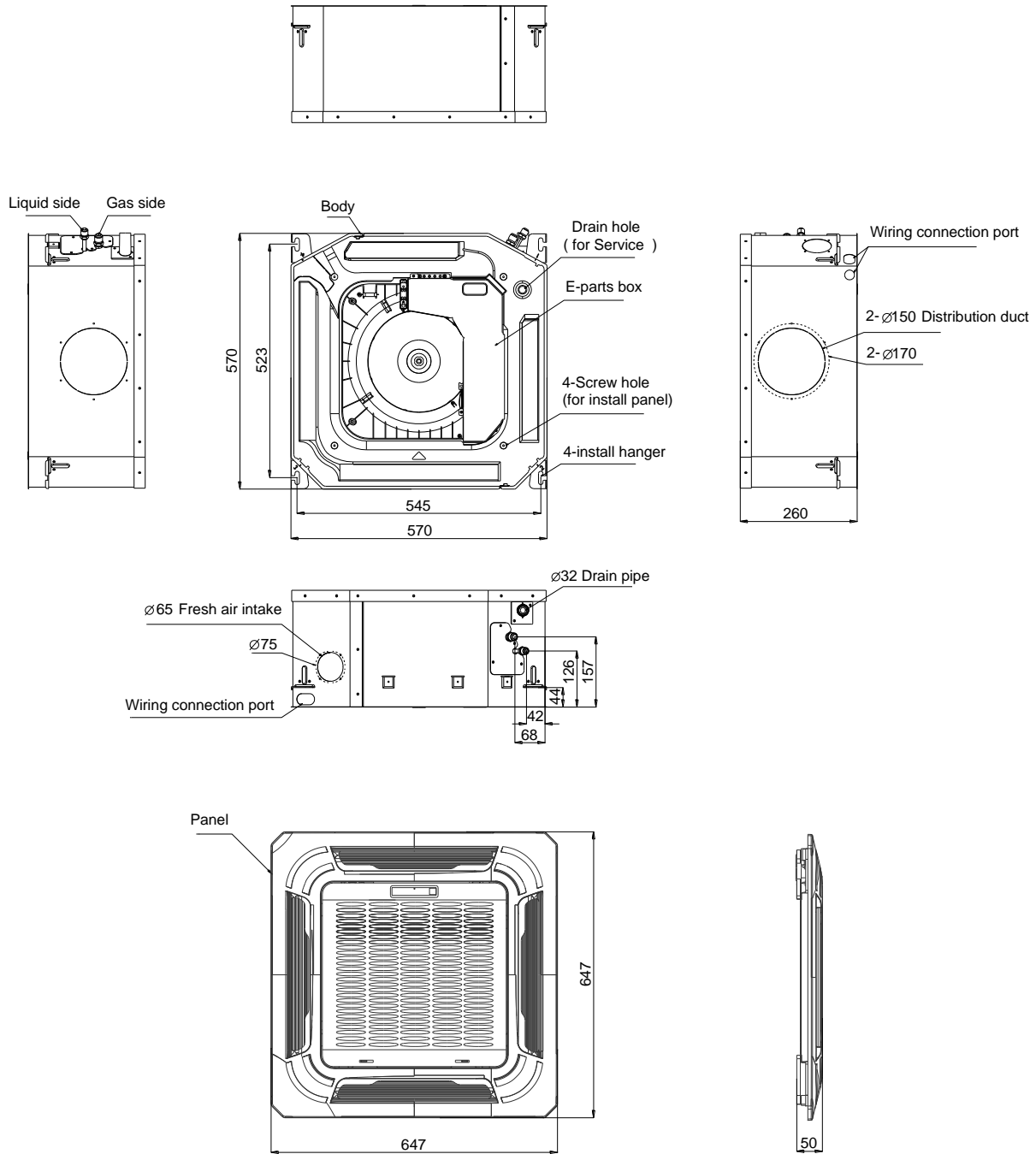

3. Service Space

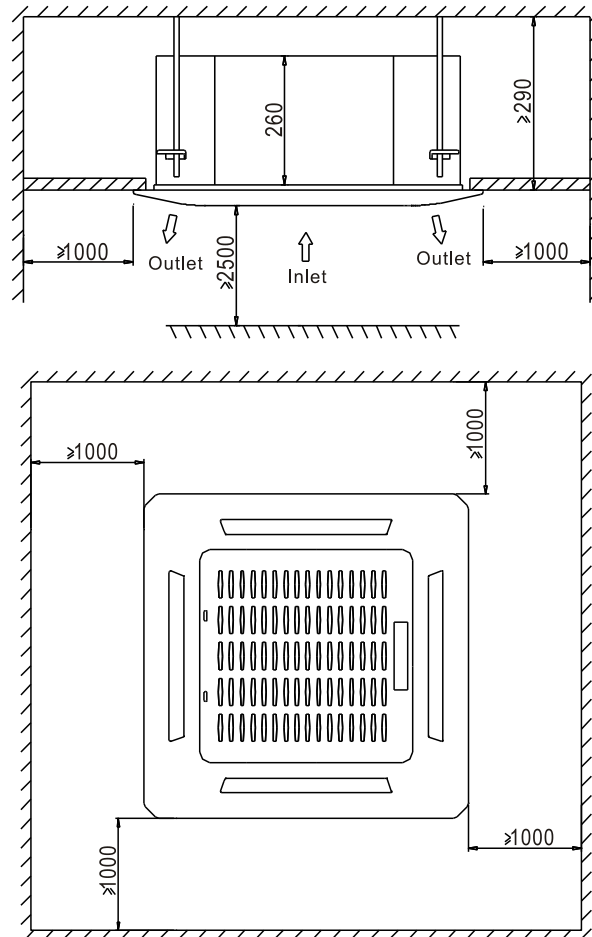

4. Wiring Diagrams

MCA3U-12HRFN1-QRD0W

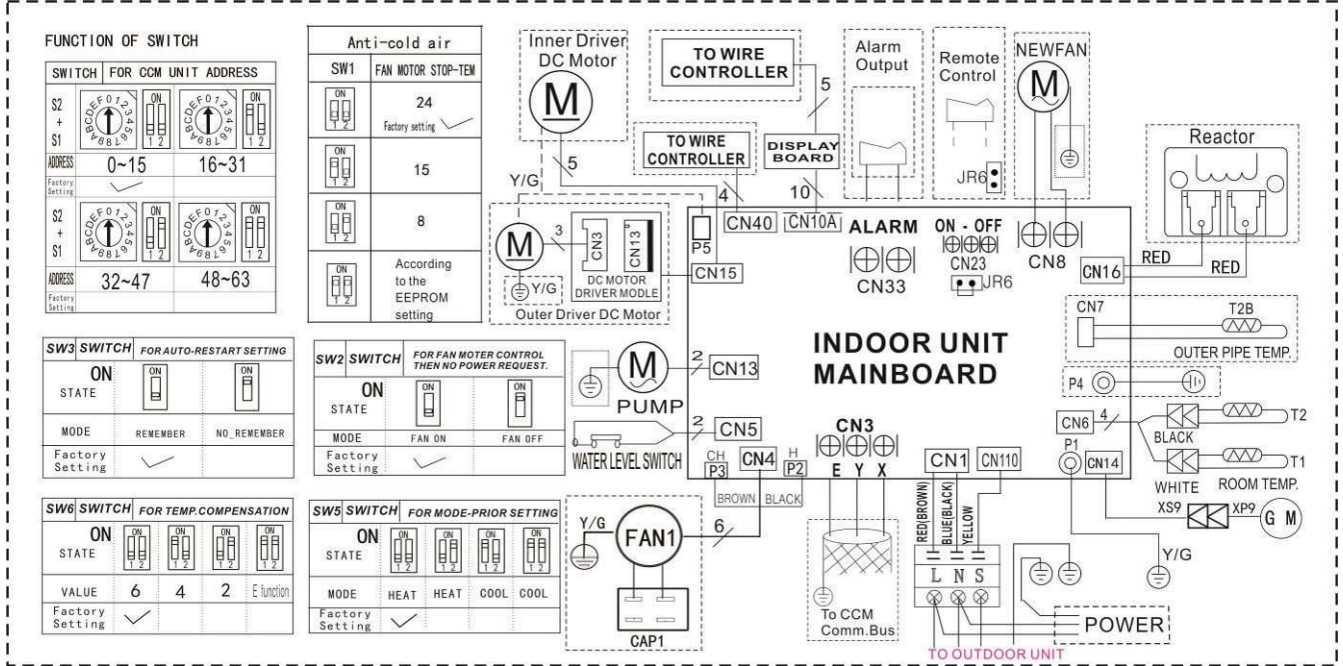

MCA3-18HRFN1-QRD0

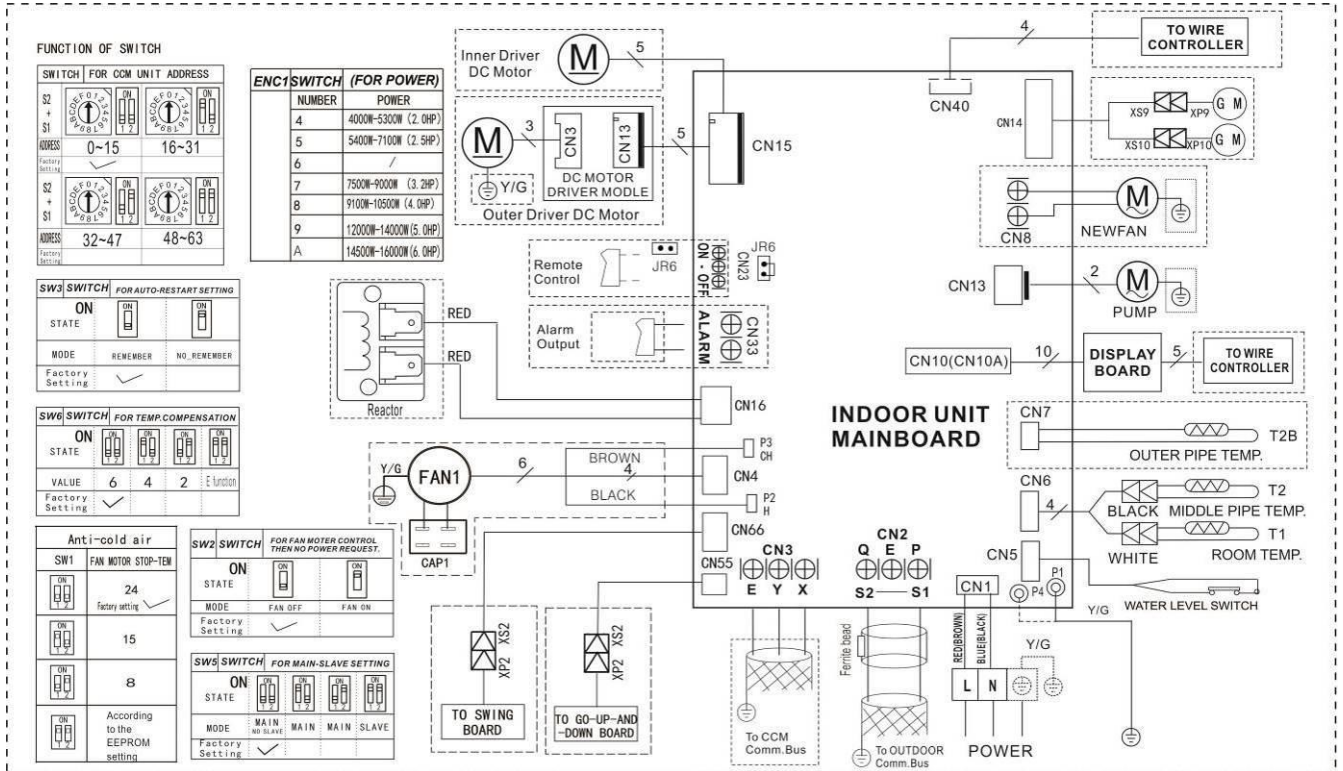

5. Air Velocity and Temperature Distributions (Reference Data)

Airflow velocity

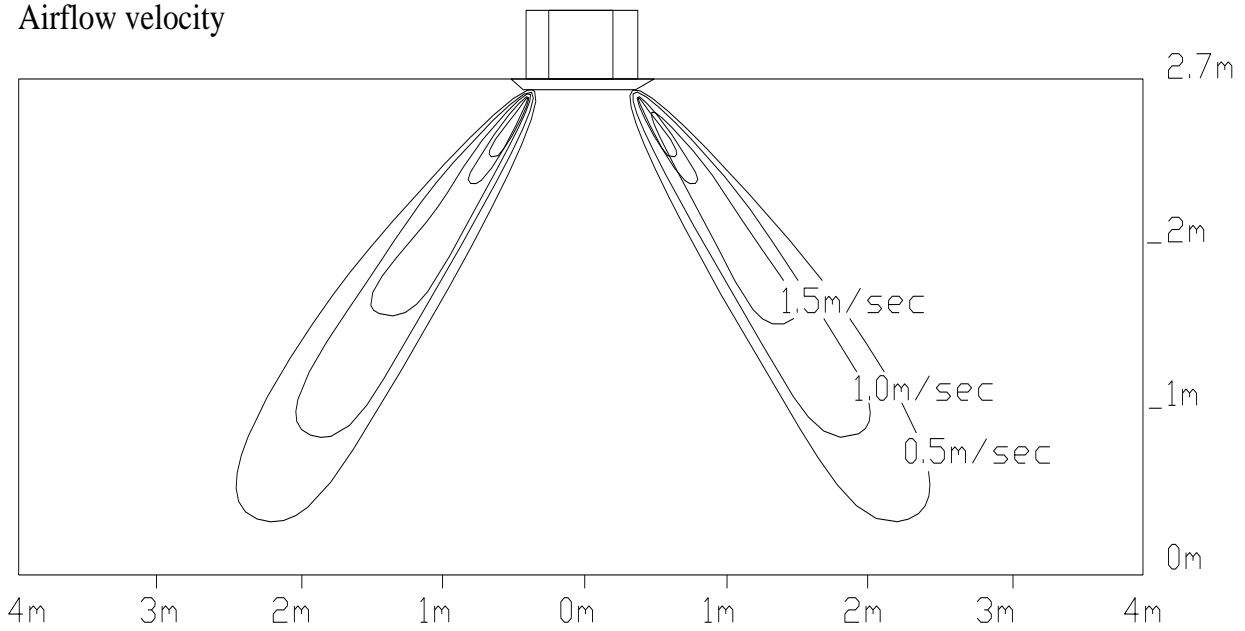

Temperature

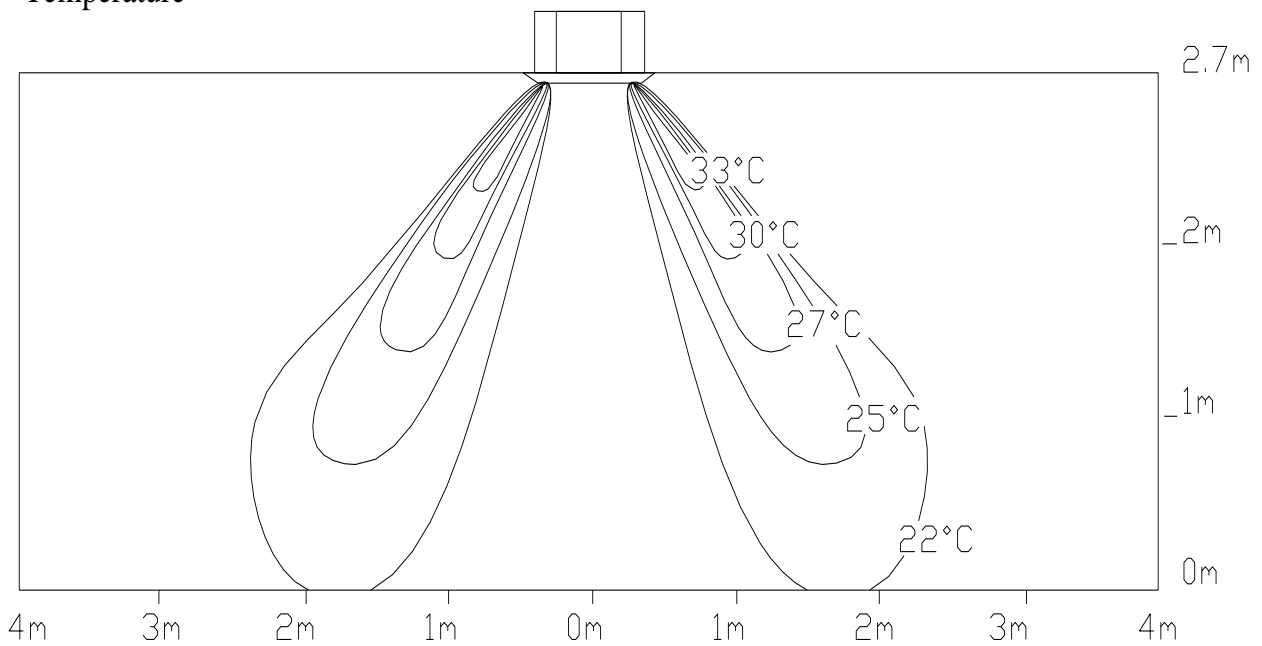

6. Electric Characteristics

Model	Indoor Units				Power Supply
	Hz	Voltage	Min.	Max.	MFA
MCA3U-12HRFN1-QRD0W	50	220-240V	198V	254V	/
MCA3-18HRFN1-QRD0	50	220-240V	198V	254V	/

Note:





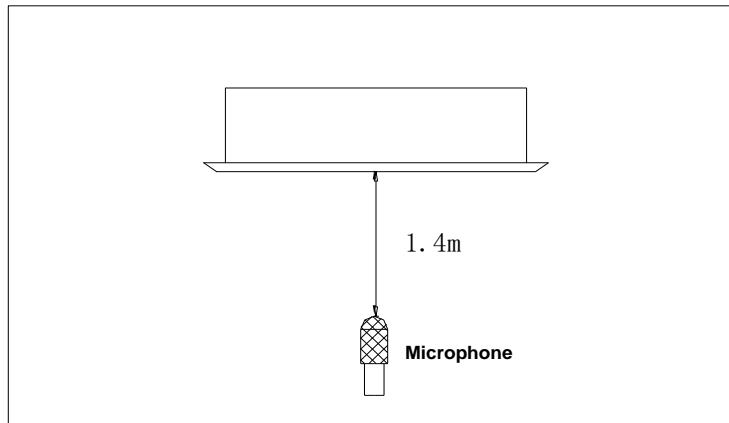









MFA: Max. Fuse Amps. (A)

7. Sound Levels

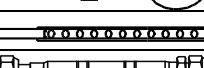
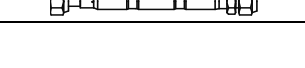

Model	Noise Power dB(A)	Noise level dB(A)		
		H	M	L
MCA3U-12HRFN1-QRD0W	58	42	38	34
MCA3-18HRFN1-QRD0	59	46	42	38

8. Accessories

	Name	Shape	Quantity
Installation Fittings	Installation paper board		1
Tubing & Fittings	Soundproof / insulation sheath		1
Drainpipe Fittings	Out-let pipe sheath		1
	Out-let pipe clasp		1
	Drain joint		1
	Seal ring		1
Remote controller & Its Frame (The product you have might not be provided the following accessories)	Remote controller & Its Frame		1
	Remote controller holder		1
	Mounting screw(ST2.9x10-C-H)		2
	Remote controller manual		1
	Alkaline dry batteries (AM4)		2
Others	Owner's manual		1
	Installation manual		1
Installation accessory (The product you have might not be provided the following accessories)	Expansive hook		4
	Installation hook		4
	Orifice		1

9. The Specification of Power

Model(Btu/h)		12000	18000
POWER	Phase	1-phase	1-phase
	Frequency and Voltage	220-240V, 50Hz	220-240V, 50Hz
	POWER WIRING (mm ²)	3x2.5	3x2.5
CIRCUIT BREAKER/Fuse (A)		20/16	30/20
Indoor/Outdoor Connecting Wiring(Weak Electric Signal) (mm ²)		—————	2x0.2
Indoor/Outdoor Connecting Wiring(Strong Electric Signal)(mm ²)		4x1.0	3x1.0

10. Field Wiring

MCA3U-12HRFN1-QRD0W

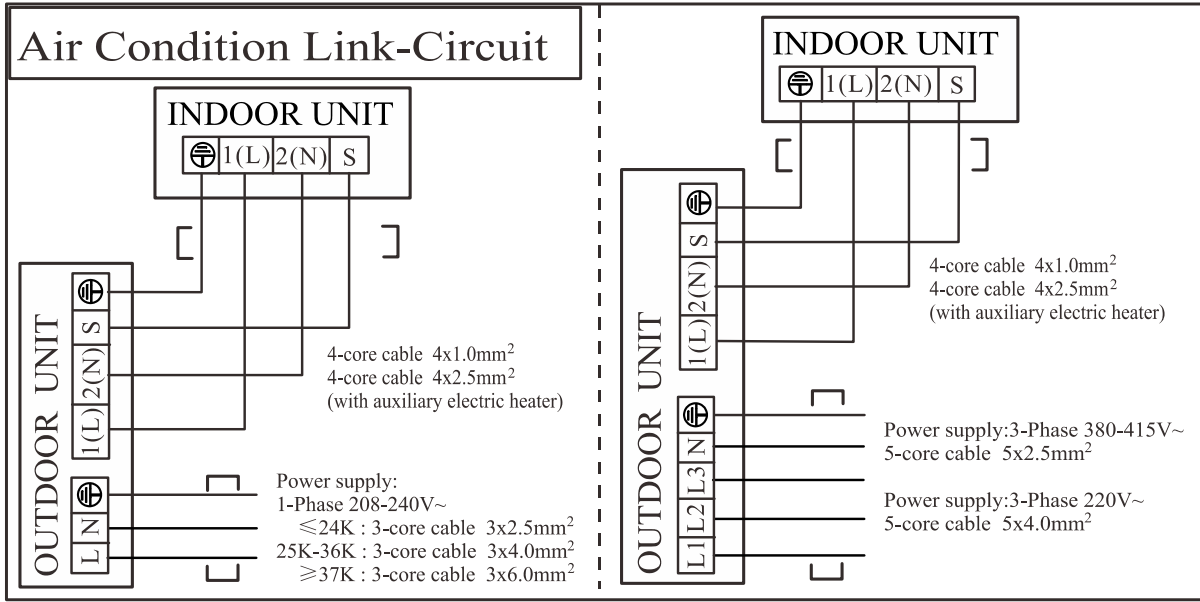

MCA3-18HRFN1-QRD0

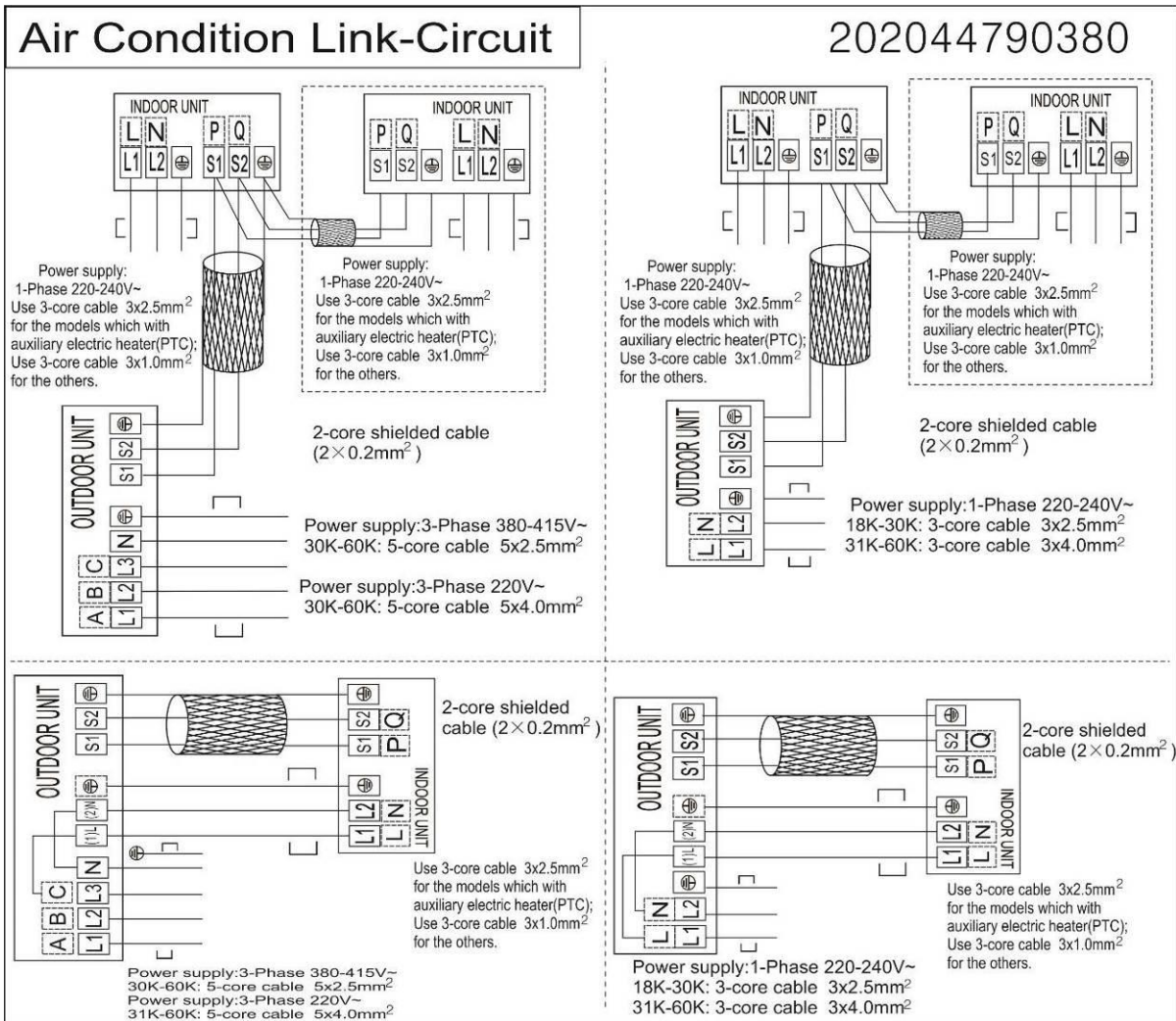

Console Type

1. Features	63
2. Dimensions	65
3. Service Space	66
4. Wiring Diagrams.....	67
5. Air Velocity and Temperature Distributions (Reference Data).....	68
6. Electric Characteristics	69
7. Sound Levels	70
8. Accessories	71
9. The Specification of Power.....	71
10. Field Wiring.....	72

1. Features

1.1. Modern and elegant appearance

- The simple and stylish designs can nicely harmonies with your living space.



1.2. Four panels optional



1.3. Two air-outlet ways Cooling mode

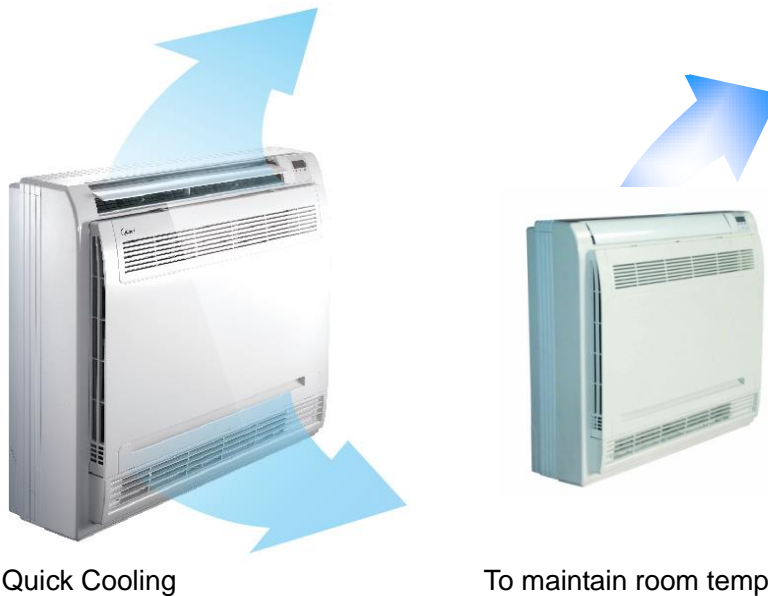

- Air outlet from top and bottom to make quick cooling -----When the A/C is just switched on, or room temp. is still high, cold air will be blown out from top and bottom air outlet to cool down the room quickly
- Air outlet from top to maintain room temp. ----When the room has been cooled down, or the A/C has been opened over 1 hour, cold air only from the top outlet to keep constant room temp

Heating mode

- Anti-cold air -----When the AC is just turn on, temperature of evaporator is very low, in this case, in

order to prevent cold air direct blowing, only the upper louver is opened in a high position, the lower louver closed.



1.4. Four air inlets



1.5. Low noise

- DC indoor fan motor, which has five speeds.
- Low noise and energy saving.



- Advanced centrifugal fan technology makes a fast airflow and reduces the indoor noise.

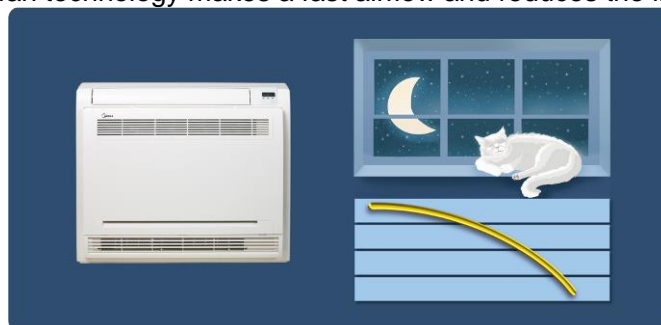

1.6. Golden fin is optional.

1.7. Active carbon filter is standard.

2. Dimensions

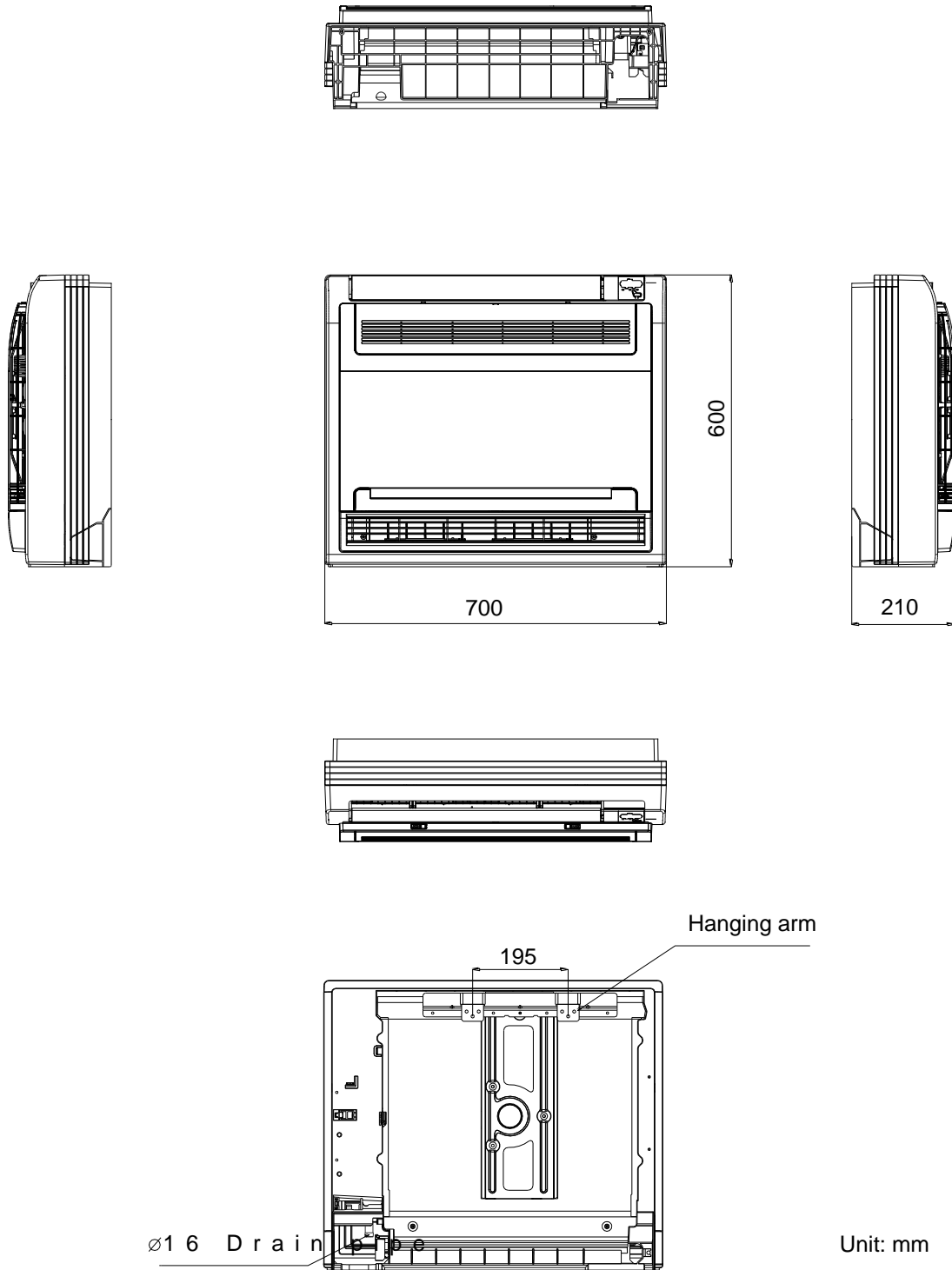

3. Service Space

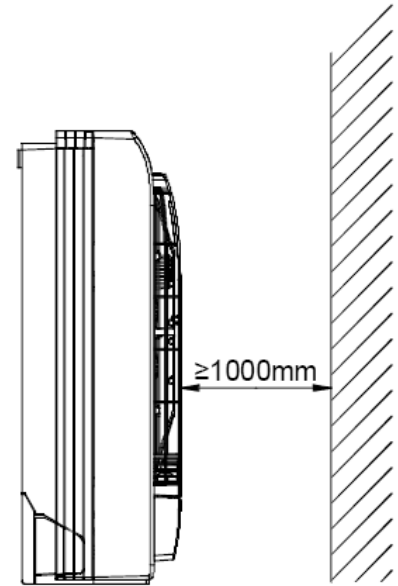
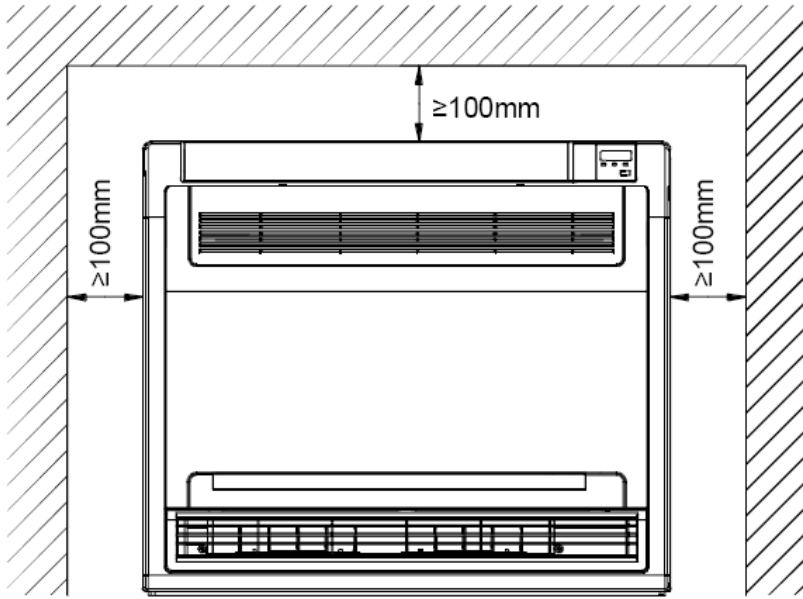

4. Wiring Diagrams

MFAU-12HRFN1-QRC8W, MFA-16HRFN1-QRC8W

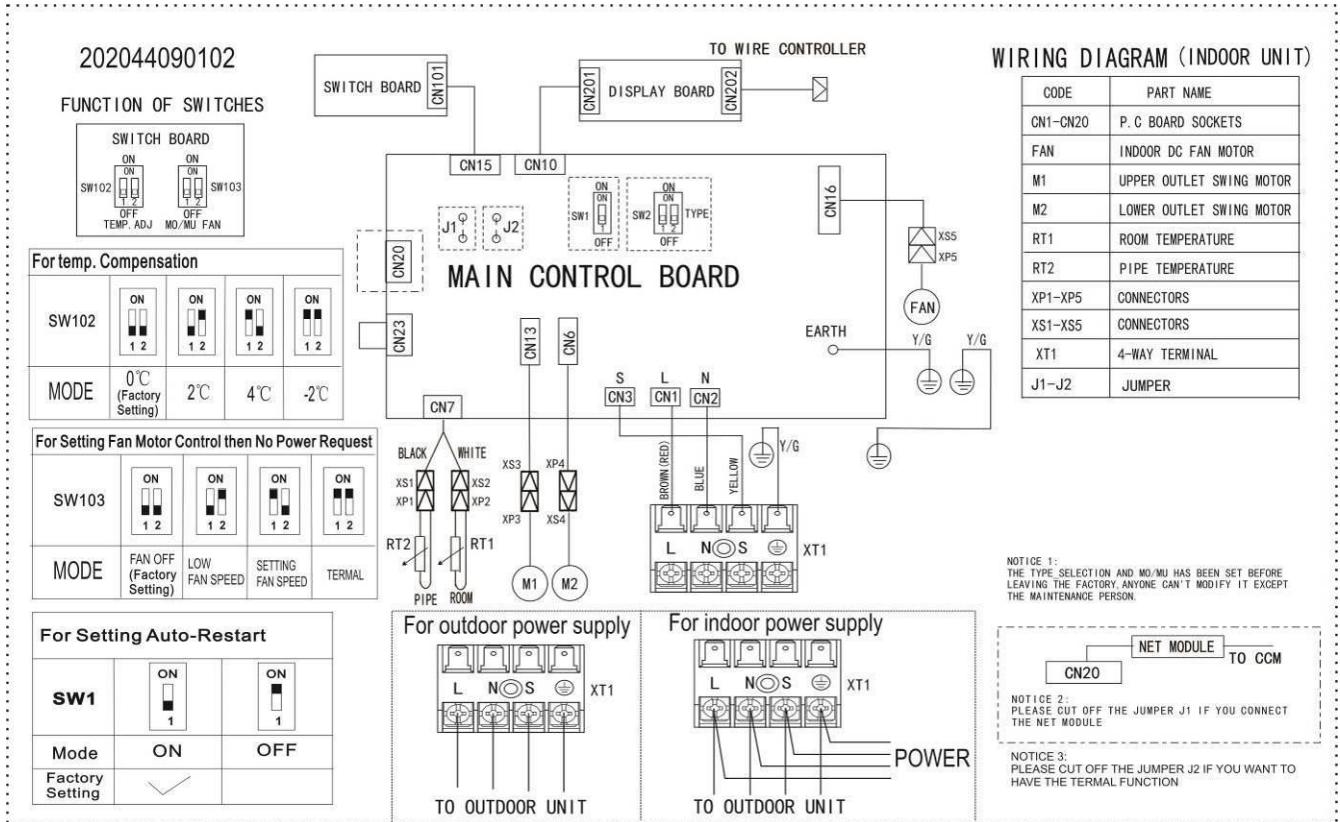

5. Air Velocity and Temperature Distributions (Reference Data)

Discharge angle 60

Airflow velocity

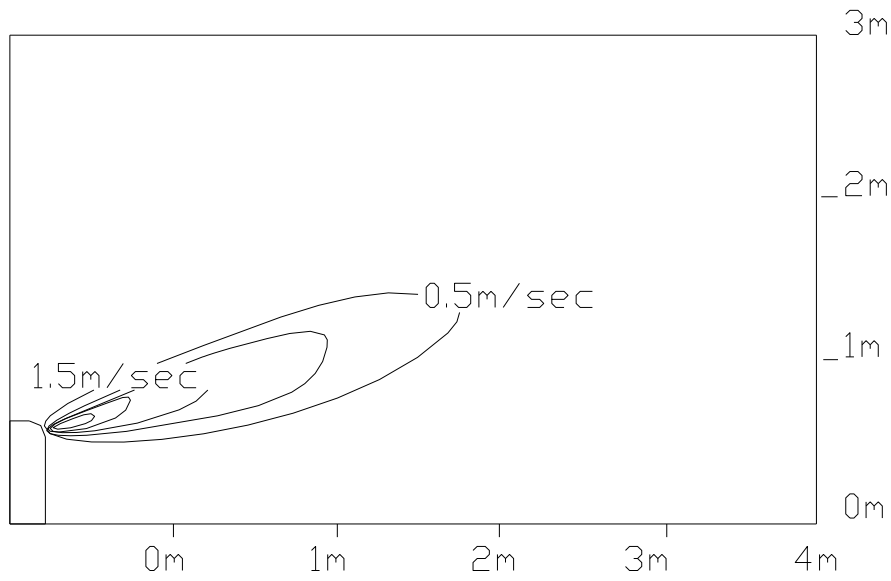

Temperature

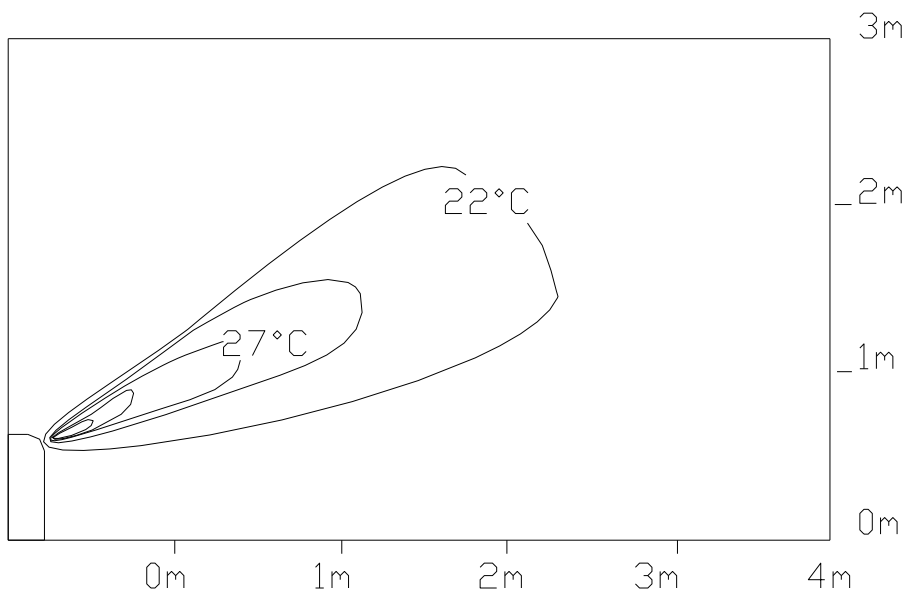

6. Electric Characteristics



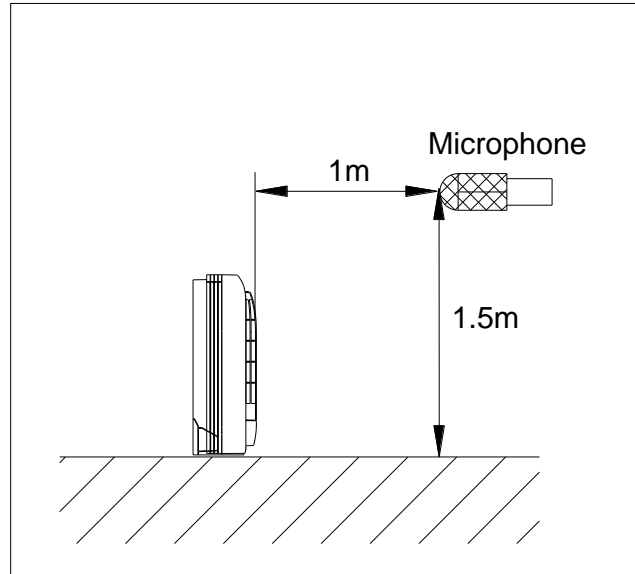

Model	Indoor Units				Power Supply
	Hz	Voltage	Min.	Max.	MFA
MFAU-12HRFN1-QRC8W	50	220-240V	198V	254V	/
MFA-16HRFN1-QRC8W	50	220-240V	198V	254V	/

7. Sound Levels



Model	Noise Power dB(A)	Noise level dB(A)		
		H	M	L
MFAU-12HRFN1-QRC8W	58	47	41	35
MFA-16HRFN1-QRC8W	58	48	41	35

8. Accessories

	Name	Shape	Quantity
Installation fittings	Hook		2
Remote controller & Its Frame	Remote controller		1
	Frame		1
	Mounting screw(ST2.9×10-C-H)		2
	Alkaline dry batteries (AM4)		2
Others	Installation manual	/	1
	Owner's manual	/	1

9. The Specification of Power

Model(Btu/h)		12000	16000
POWER	Phase	1-phase	1-phase
	Frequency and Voltage	220-240V, 50Hz	220-240V, 50Hz
	POWER WIRING (mm ²)	3×2.5	3×2.5
CIRCUIT BREAKER/Fuse (A)		20/16	30/20
Indoor/Outdoor Connecting Wiring(Weak Electric Signal) (mm ²)		—————	—————
Indoor/Outdoor Connecting Wiring(Strong Electric Signal)(mm ²)		4×1.0	4×1.0

10. Field Wiring

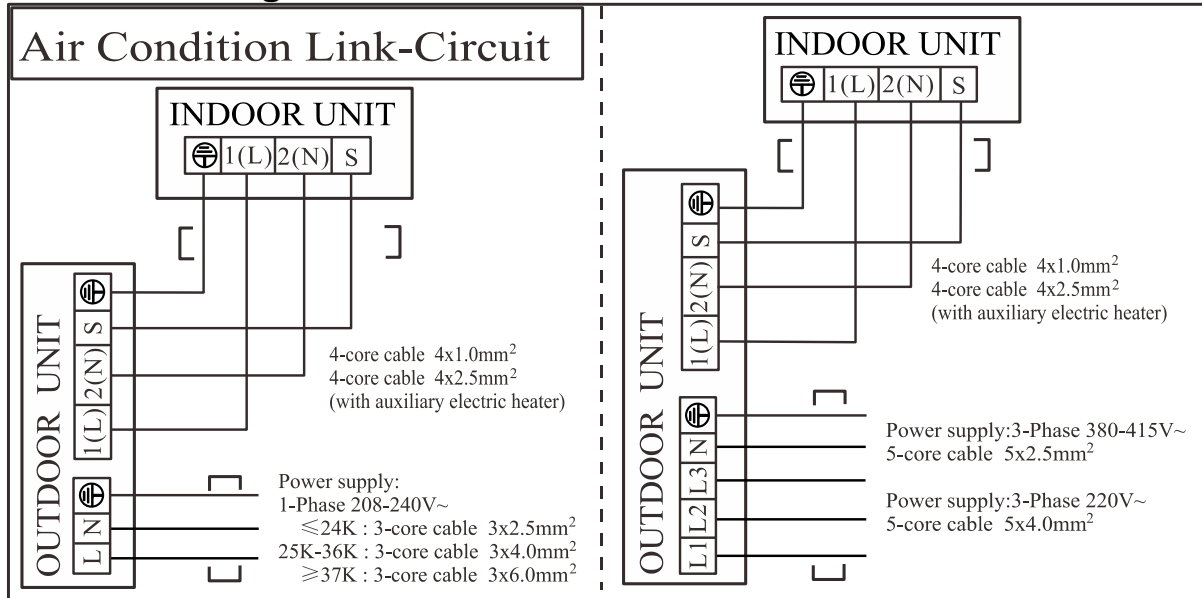

M Floor-standing Type

1.Features	74
2. Dimensions.....	75
3. Service Space.....	76
4. Wiring Diagrams	77
5. Electric Characteristics	78
6. Sound Levels.....	79
7. Accessories.....	80
8. The Specification of Power	81
9. Field Wiring	82

1. Features

1.1 Fashionable design, concise and easy design better suits decoration style.



1.2. Dustproof Air Outlet

When press OFF to turn off the unit, the air outlet louver can be closed automatically to prevent the dust falling in.

1.3. Easy Control

Big LCD display shows multi-information very clearly.
Slight-touch buttons make the operation easy, clear and precise.

1.4. Comfortable Air Flow

Long distance air supply.
3D air distribution(Vertical and horizontal louvers auto swing)(optional)

1.5. Fresh Air (Optional)

A fresh air inlet can be customized on the return air channel. When the indoor fan runs, the fresh air will be sucked inside through the fresh air pipe, which makes the air more clear and healthy.

1.6 Double Air Filters (Optional)

Various healthy filters are optional.

1.7 Ionizer (Optional)

Ionizer generator brings refreshing air to your room.

2. Dimensions

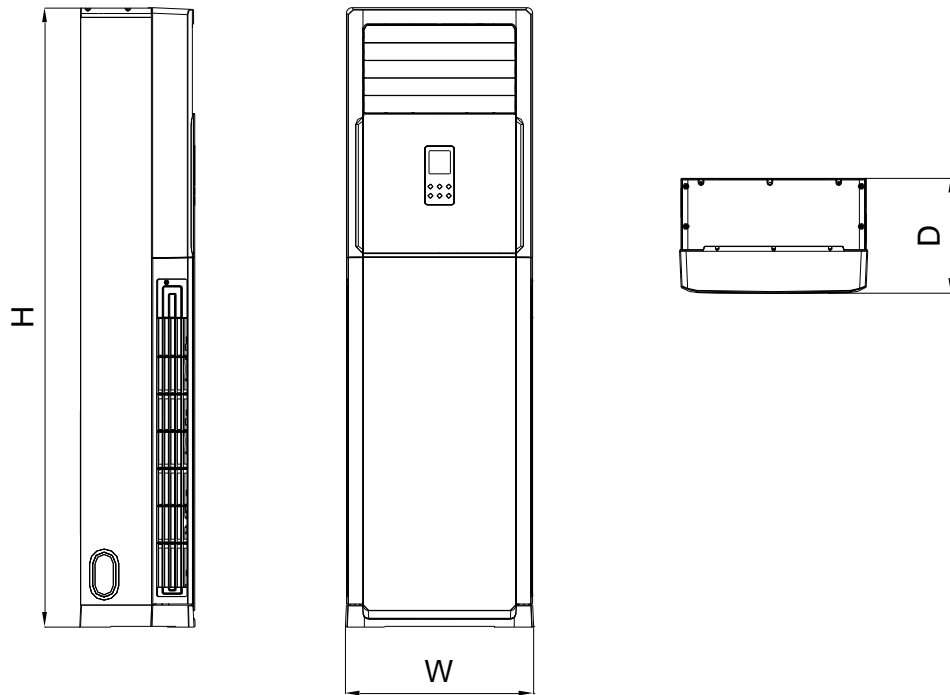

Model \ Dimension	W(mm)	D(mm)	H(mm)
MFM-24HRFN1-QRD0	500	315	1700

3. Service Space

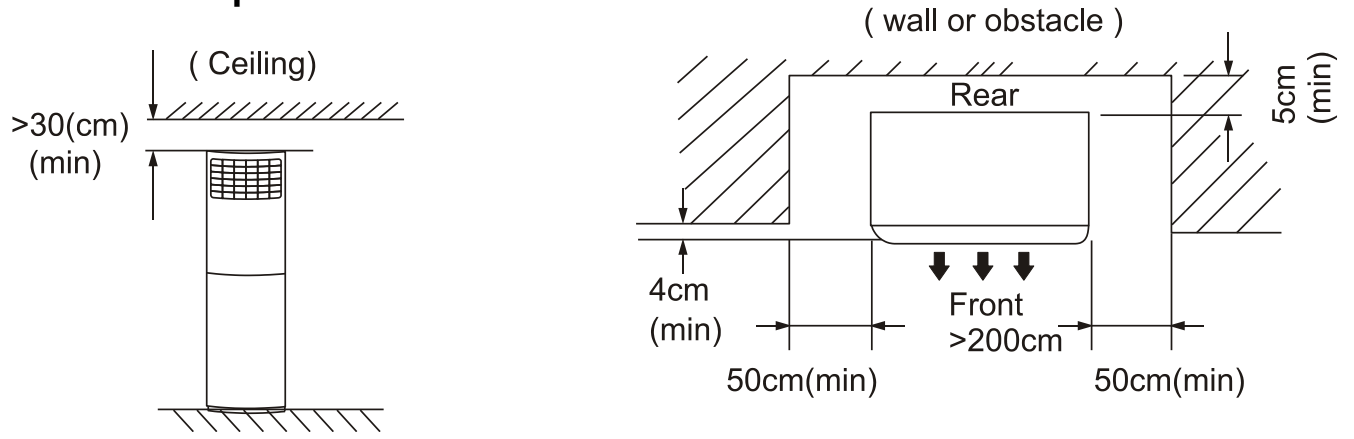

4. Wiring Diagrams

MFM-24HRFN1-QRD0

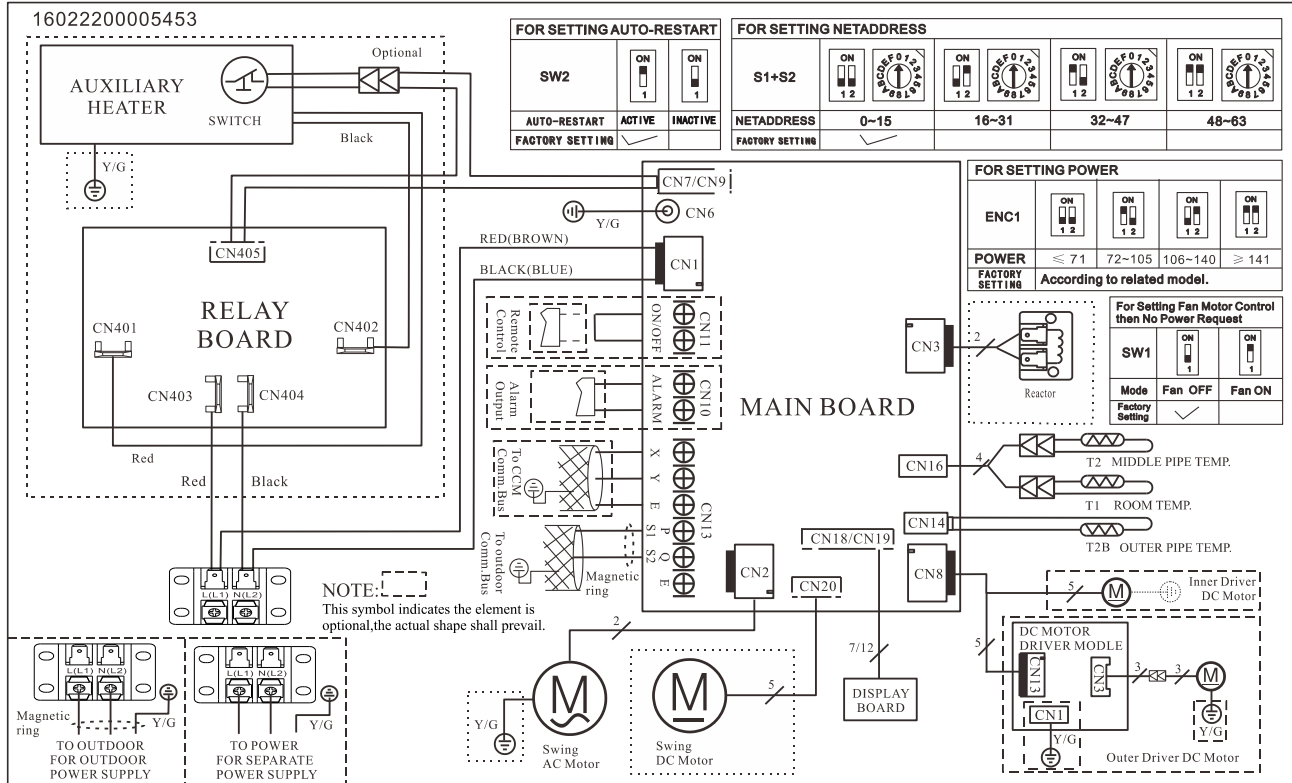

5. Electric Characteristics

Model	Indoor Units				Power Supply
	Hz	Voltage	Min.	Max.	MFA
MFM-24HRFN1-QRD0	50	220-240V	198V	254V	/

Note:





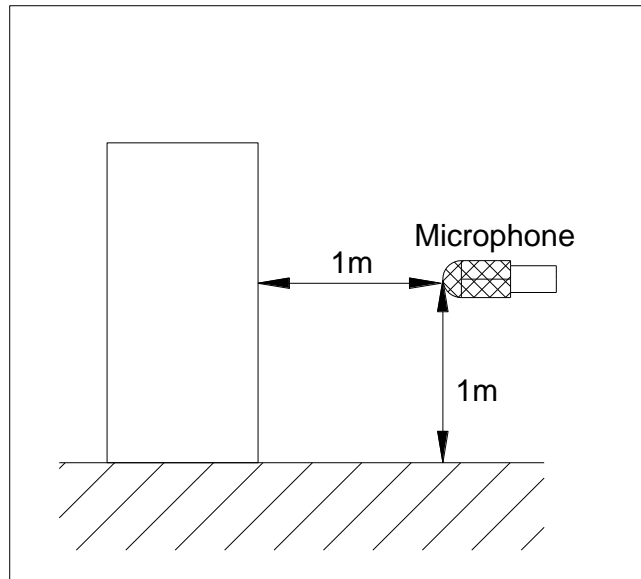











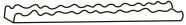

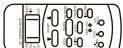
MFA: Max. Fuse Amps. (A)

6. Sound Levels



Model	Sound Power Level dB(A)	Noise level dB(A)		
		H	M	L
MFM-24HRFN1-QRD0	63	49.5	46	43.5

7. Accessories

NO.	Part Name	Shape	Quantity
1	Safety Lock		1
2	Self-tapping Screw 3.9x25		2
3	Flat Washers		2
4	Bushing-Sleeve Cover		1
5	Sound/Heat Insulation Sleeves		2
6	Seal		1
7	Drain joint		1
8	Pipe - hole - protection Ring		1
9	Remote Battery		2
10	Remote Controller		1
11	Remote controller manual		1
12	User's manual		1
13	Installation manual		1
14	Remote controller holder(Optional parts)		1
15	Ratproof board(on some models)		1
16	Band(on some models)		2
17	Drain Hose(on some models)		1
18	Connection Cables(on some models)		1
19	Putty(on some models)		1

8. The Specification of Power

Model(Btu/h)		24000
POWER	Phase	1-phase
	Frequency and Voltage	220-240V, 50Hz
	POWER WIRING (mm ²)	3×2.5
CIRCUIT BREAKER/Fuse (A)		30/20
Indoor/Outdoor Connecting Wiring(Weak Electric Signal) (mm ²)		2×0.2
Indoor/Outdoor Connecting Wiring(Strong Electric Signal)(mm ²)		3×1.0

9. Field Wiring

Air Condition Link-Circuit

202044790380

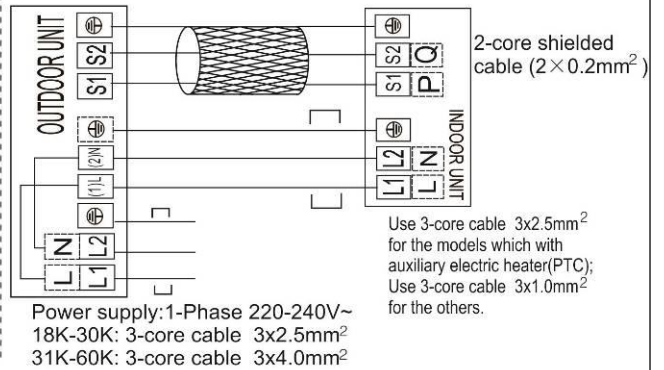
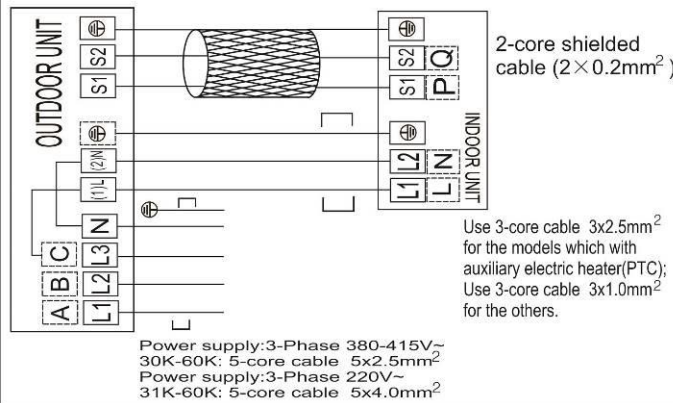
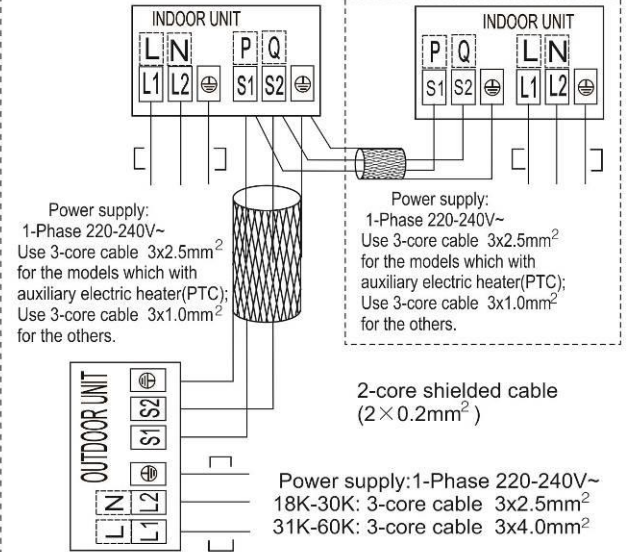
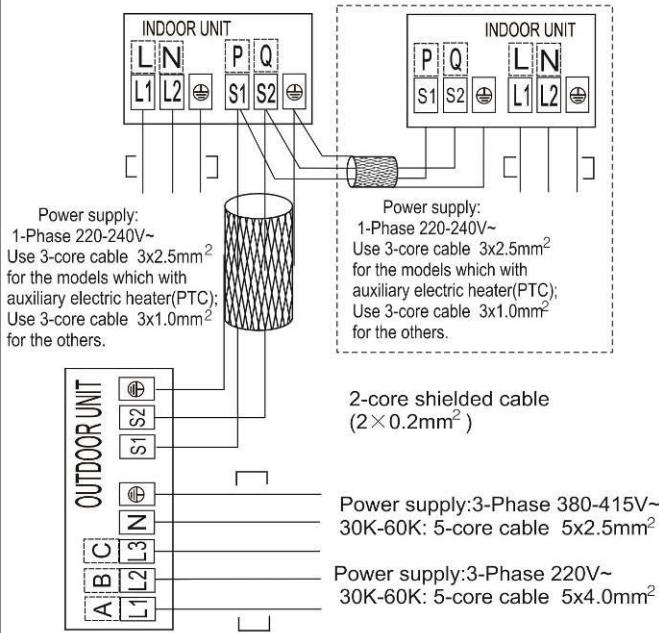

GA Floor-standing Type

1. Features	84
2. Dimensions	85
3. Service Space.....	86
4. Wiring Diagrams	87
5. Air Velocity and Temperature Distributions (Reference Data)	88
6. Electric Characteristics	89
7. Sound Levels.....	90
8. Accessories.....	91
9. The Specification of Power	92
10. Field Wiring.....	93

1. Features

1.1. Fashionable design, more modern and elegant appearance.



1.2. Air Outlet Dustproof

When turned off, the air outlet louver of the unit can be closed manually to prevent the dust falling in.

1.3. Simple and bright panel

Adopts simple and bright style panel, GA series are suitable for most different space, and show in good taste.

1.4. Big LCD display, easy to read and to operate



1.5. Optional GA1 & GA2 panel, healthy filter and auto-restart function

2. Dimensions

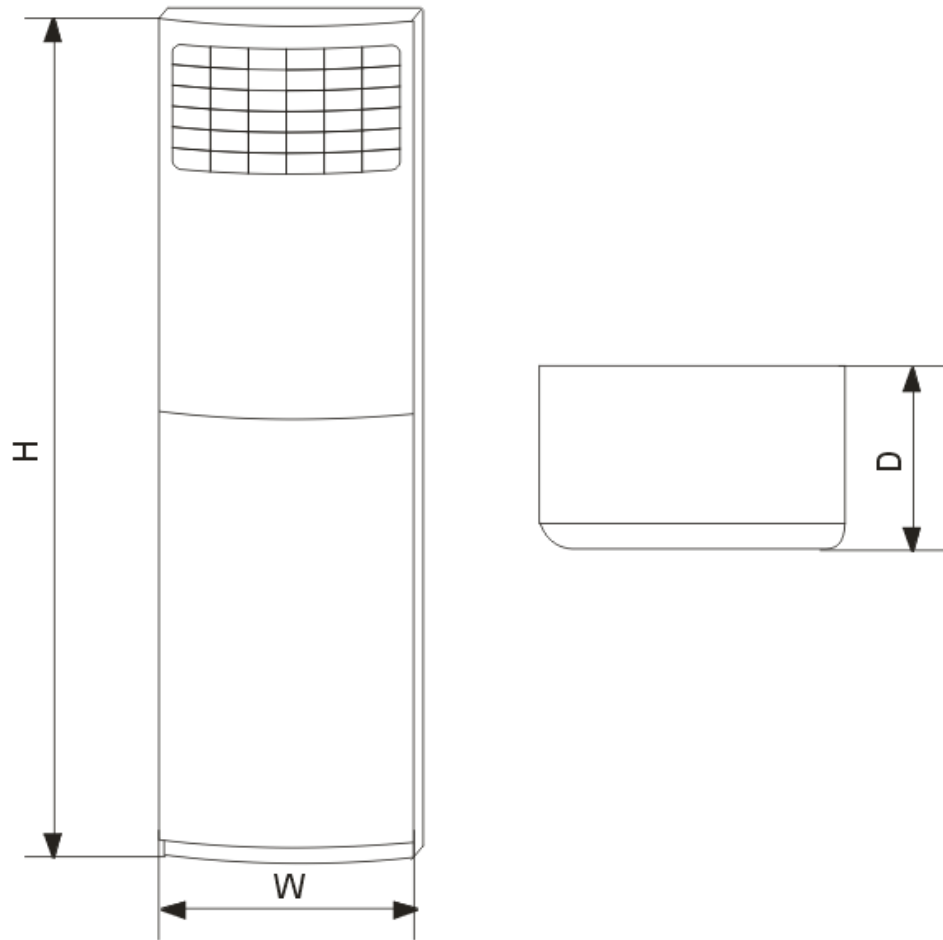

Mode / Dimension	W(mm)	D(mm)	H(mm)
MFGA-55ARFN1-RRD0(B)	610	390	1925

3. Service Space

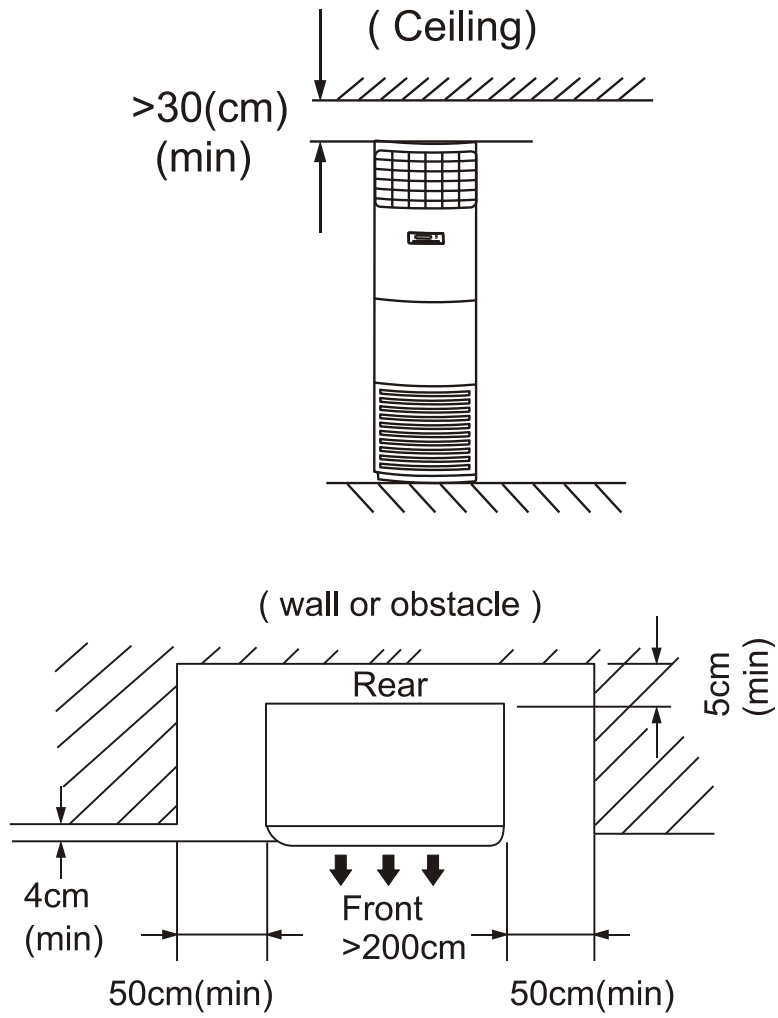

4. Wiring Diagrams

MFGA-55ARFN1-RRD0(B)

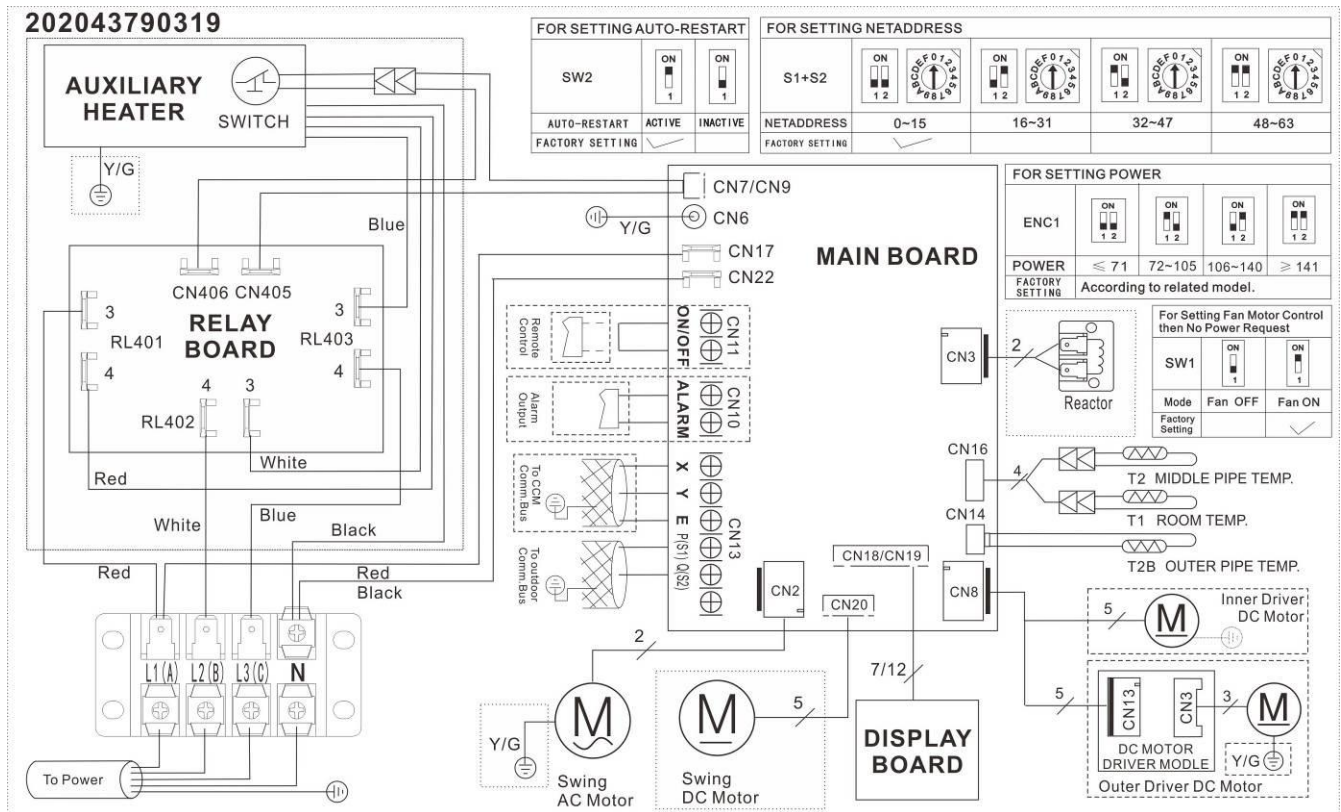

5. Air Velocity and Temperature Distributions (Reference Data)

Model 55K :

Airflow velocity

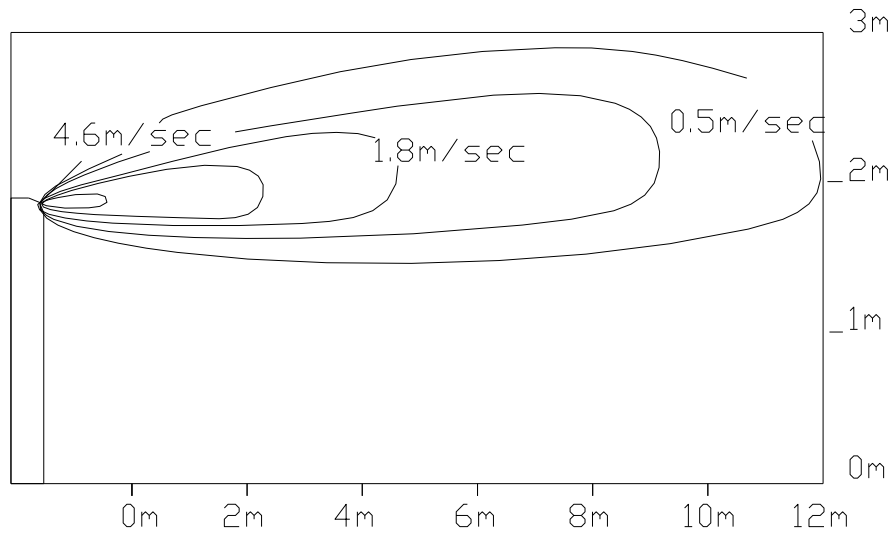

Temperature

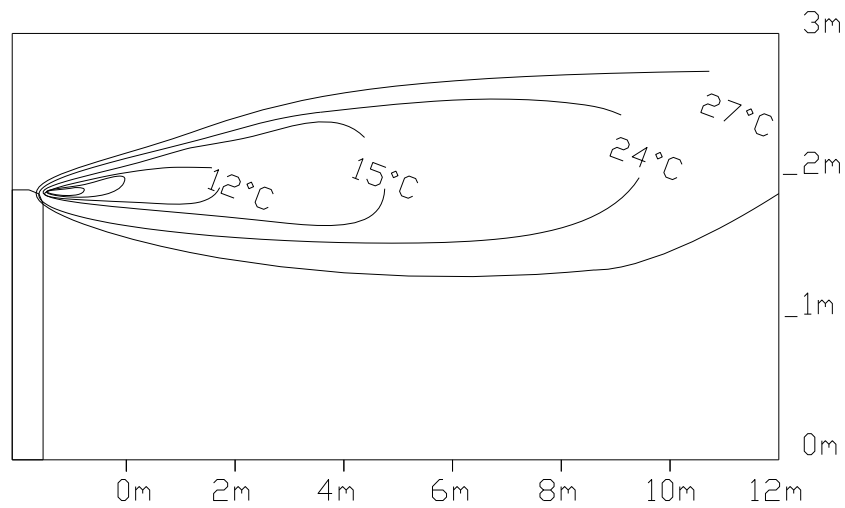

6. Electric Characteristics

Model	Indoor Units				Power Supply
	Hz	Voltage	Min.	Max.	MFA
MFGA-55ARFN1-RRD0(B)	50	220-240V	198V	254V	10

Note:





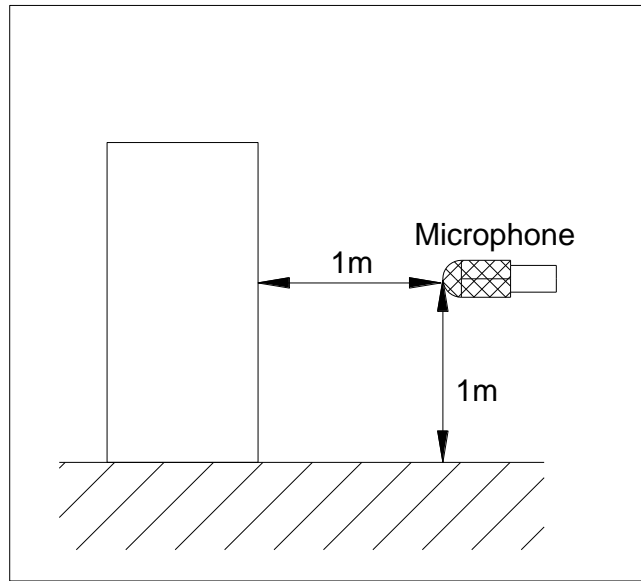







MFA: Max. Fuse Amps. (A)

7. Sound Levels

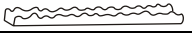

Model	Sound Power Level dB(A)	Noise level dB(A)		
		H	M	L
MFGA-55ARFN1-RRD0(B)	67	59	53	47

8. Accessories

NO.	Part Name	Shape	Quantity
1	Safety Lock		1
2	Self-tapping Screw 3.9x25		2
3	Flat Washers		2
4	Bushing-Sleeve Cover		1
5	Sound/Heat Insulation Sleeves		2
6	Seal		1
7	Drain joint		1
8	Pipe - hole - protection Ring		1
9	Remote Battery		2
10	Remote Controller		1
11	Connection Cables		1
12	Remote controller manual		1
13	User's manual		1
14	Installation manual		1

9. The Specification of Power

Model		MFGA-55ARFN1-RRD0(B)
INDOOR UNIT POWER	Phase	1-phase
	Frequency and Voltage	220-240V, 50Hz
	Power Wiring (mm ²)	3×2.5
	Circuit Breaker (A)	15/10
OUTDOOR UNIT POWER	Phase	3-phase
	Frequency and Voltage	380-415V, 50Hz
	Power Wiring (mm ²)	5×2.5
	Circuit Breaker (A)	30/25
Indoor/Outdoor Connecting Wiring (Weak Electric Signal) (mm ²)		2×0.2
Indoor/Outdoor Connecting Wiring (Strong Electric Signal) (mm ²)		—————

10. Field Wiring

Air Condition Link-Circuit

202044790380

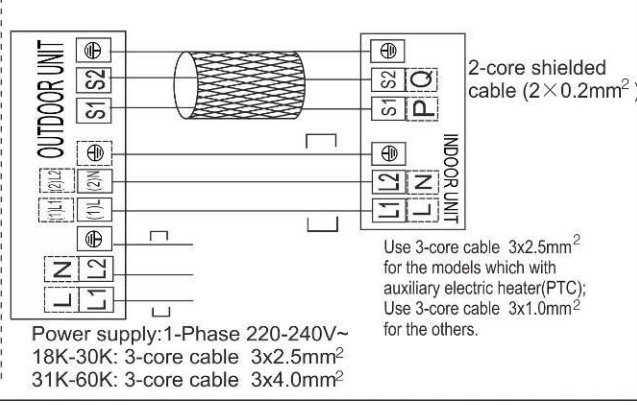
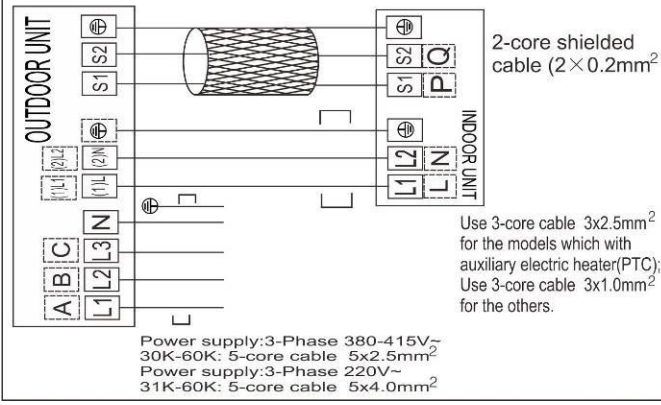
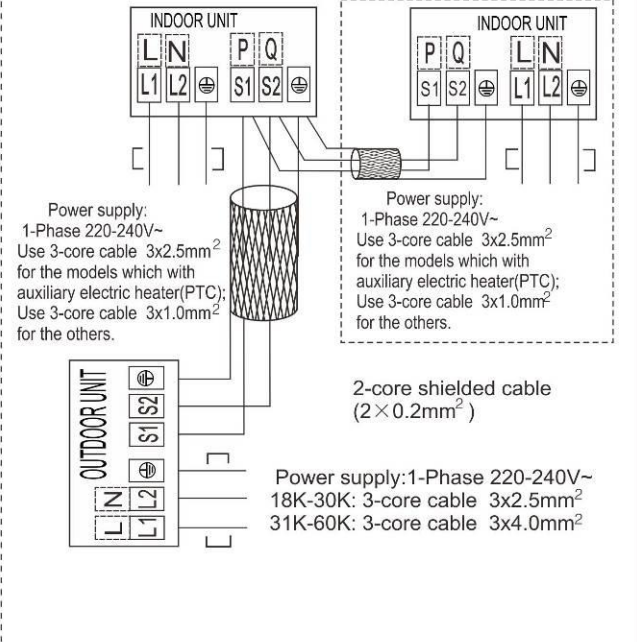
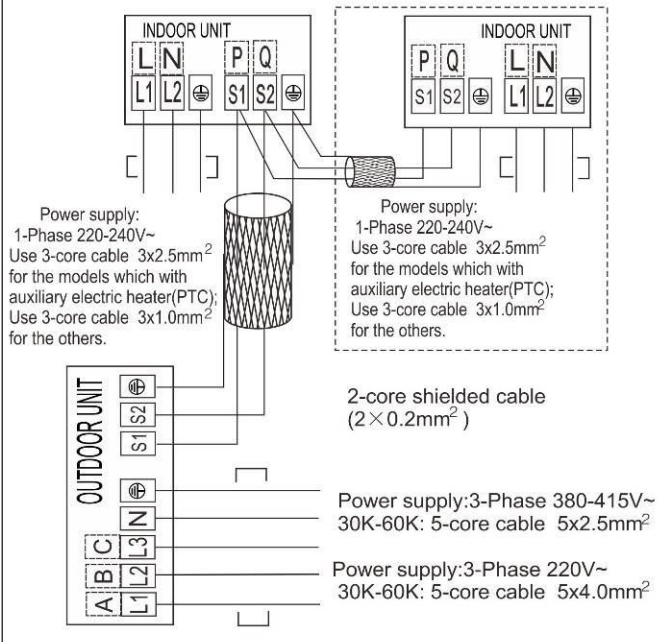

Part 3

Outdoor Units

1. Dimensions.....	95
2. Service Space.....	97
3. Wiring Diagrams	98
4. Piping Diagrams.....	103
5. Electric Characteristics	104
6. Operation Limits.....	105
7. Sound Levels.....	106

1. Dimensions

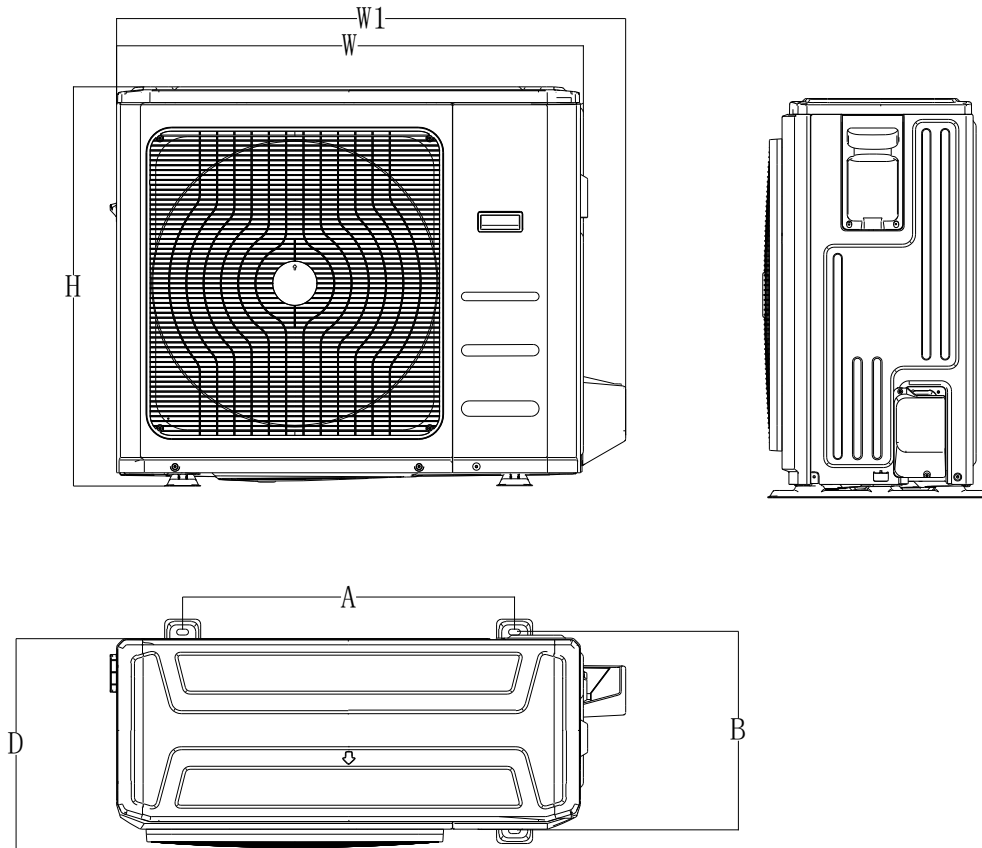

Model(KBtu/h)	Unit : mm					
	W	D	H	W1	A	B
12/16/18	800	333	554	870	514	340
24	845	363	702	914	540	350
30/36/42	946	410	810	1030	673	403

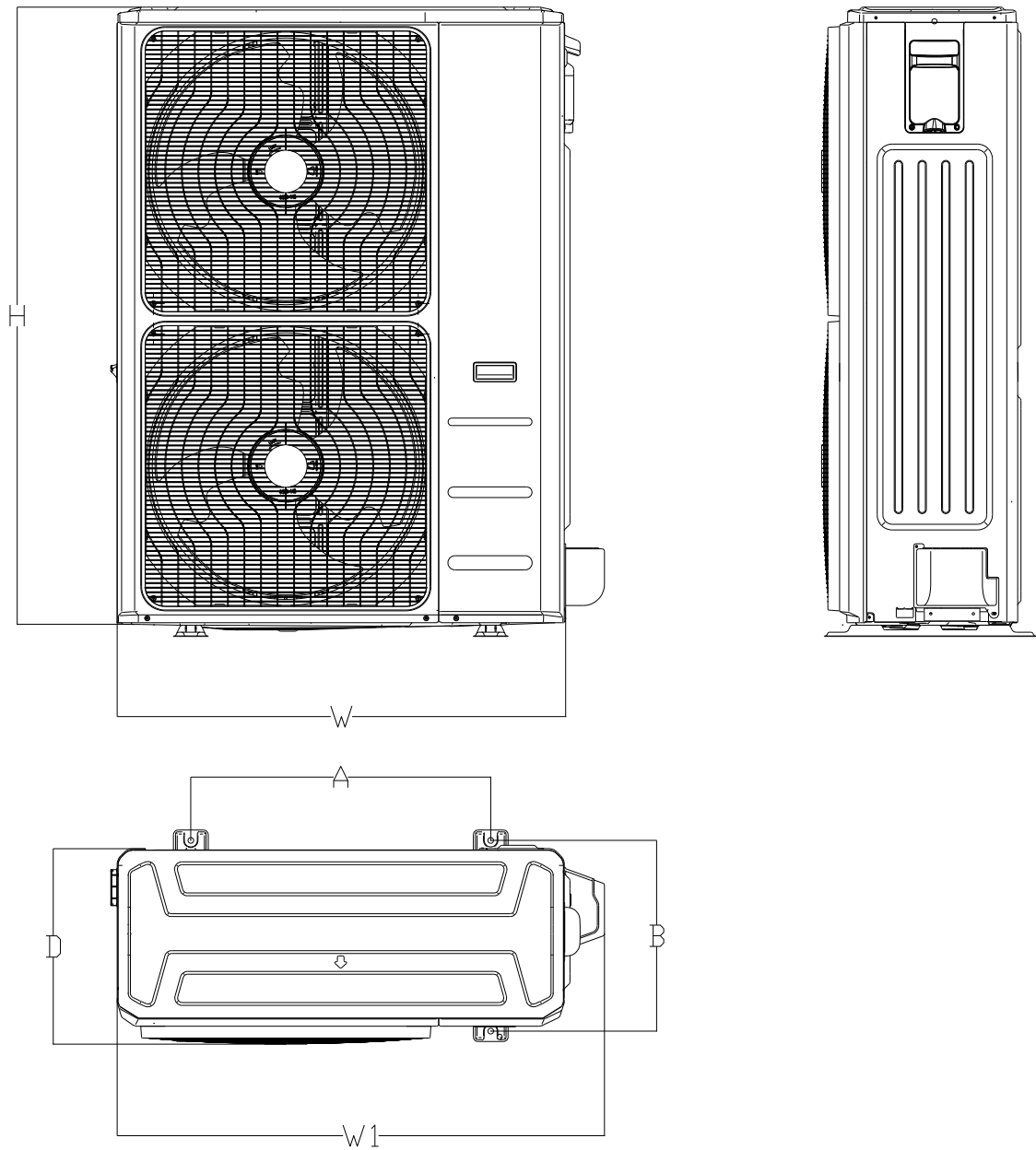

Model(KBtu/h)	Unit : mm					
	W	D	H	W1	A	B
48/55	952	415	1333	1045	634	404

2. Service Space

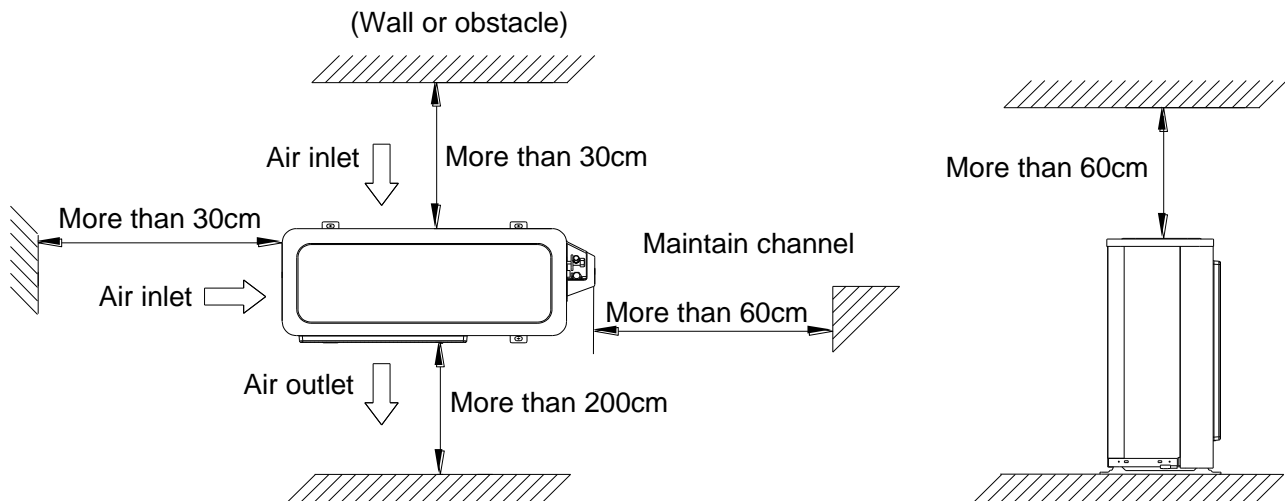

3. Wiring Diagrams

MOB30U-12HFN1-QRD0W

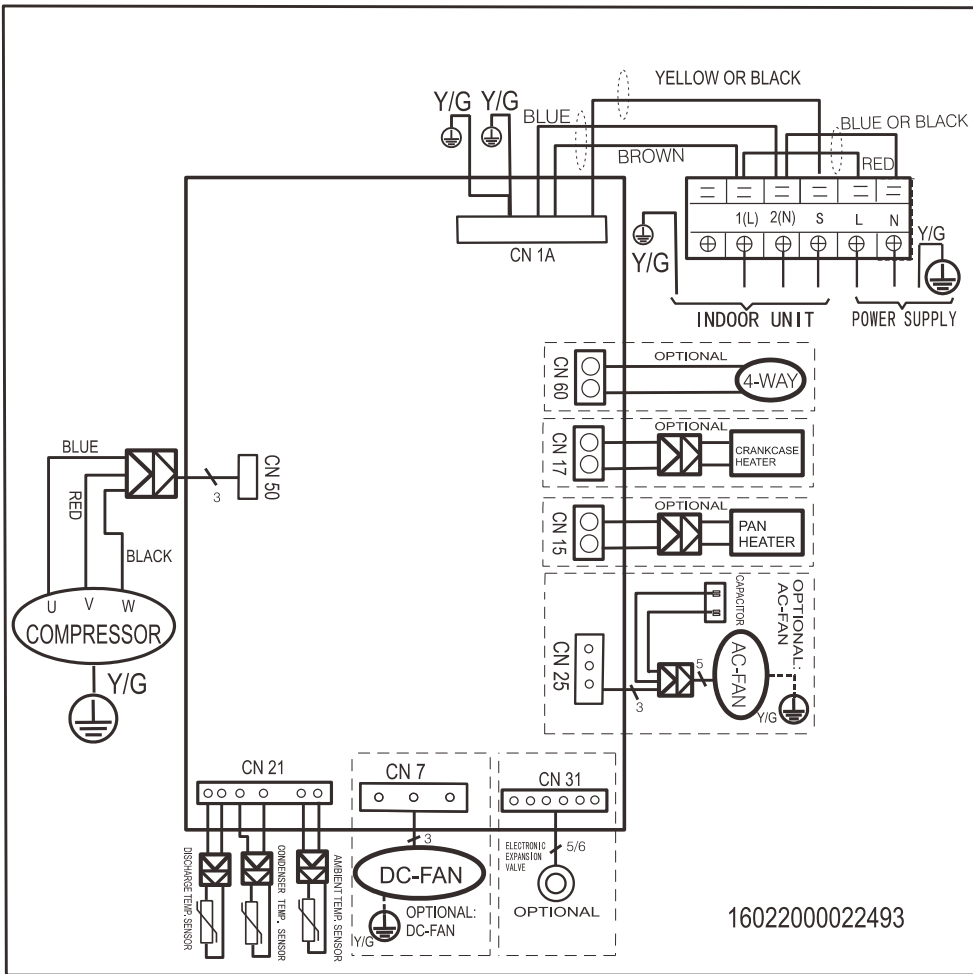

MOB30U-16HFN1-QRC8W

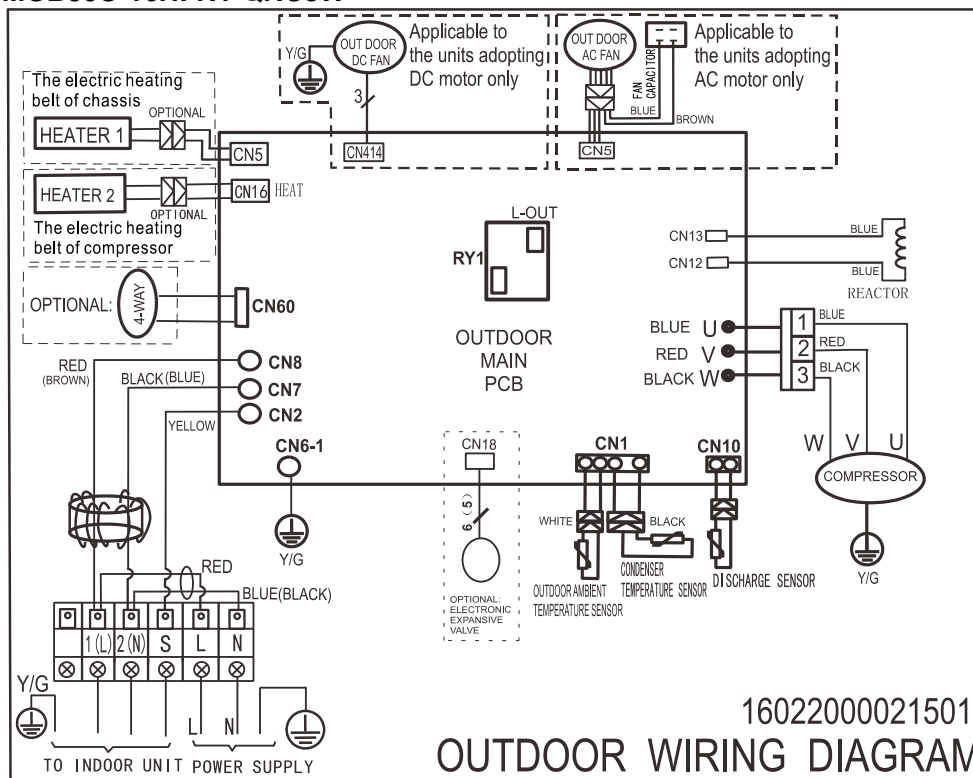

MOB30U-18HFN1-QRD0

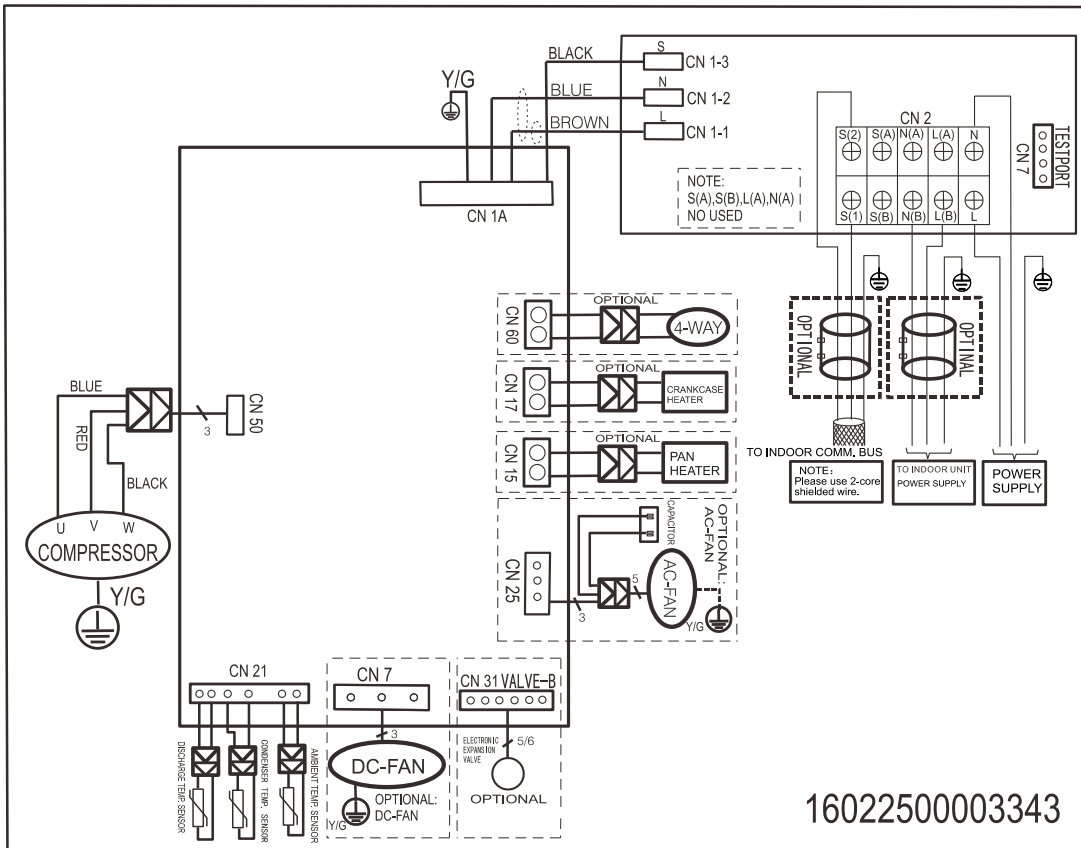

MOCA30U-24HFN1-QRD0, MOD30U-30HFN1-QRD0

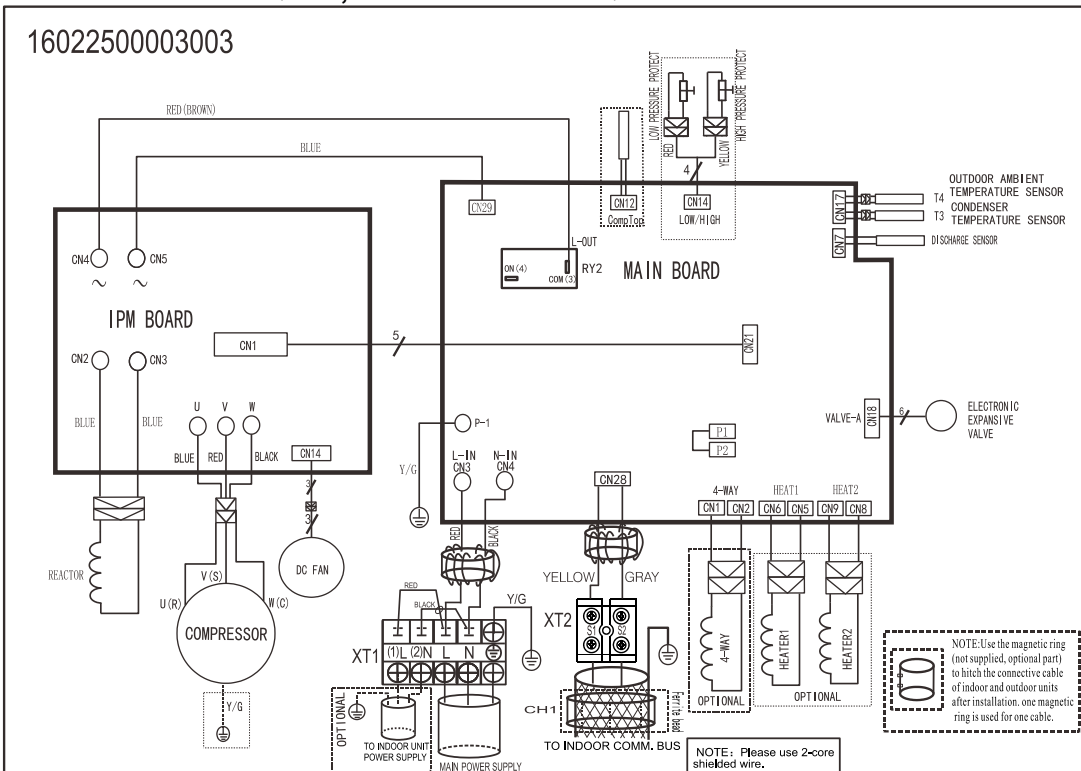

MOD30U-36HFN1-QRD0, MOD30U-42HFN1-QRD0

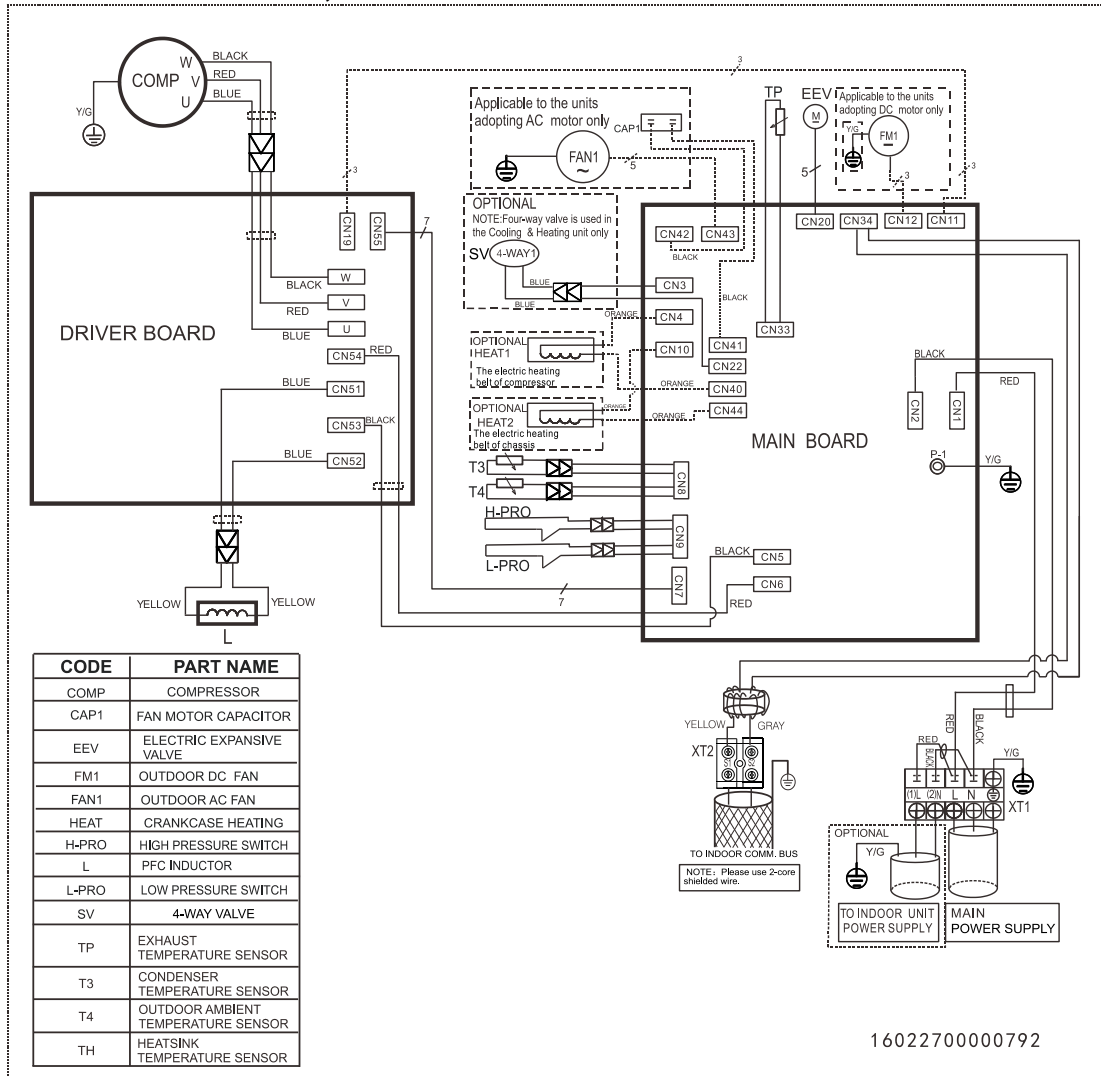

1602270000792

MOD30U-36HFN1-RRD0, MOD30U-42HFN1-RRD0

WIRING DIAGRAM (OUTDOOR UNIT)

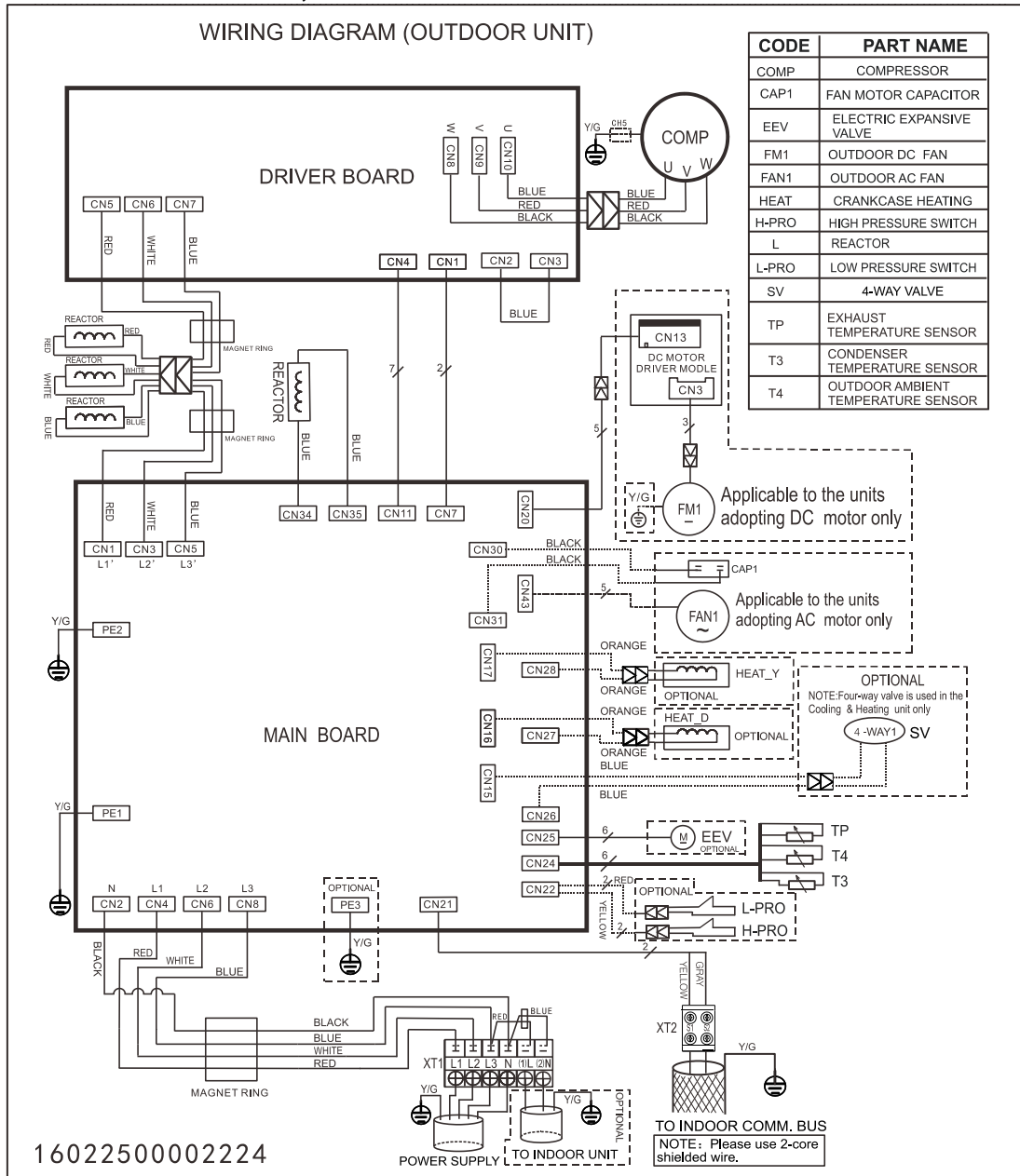

MOE30U-48HFN1-QRD0

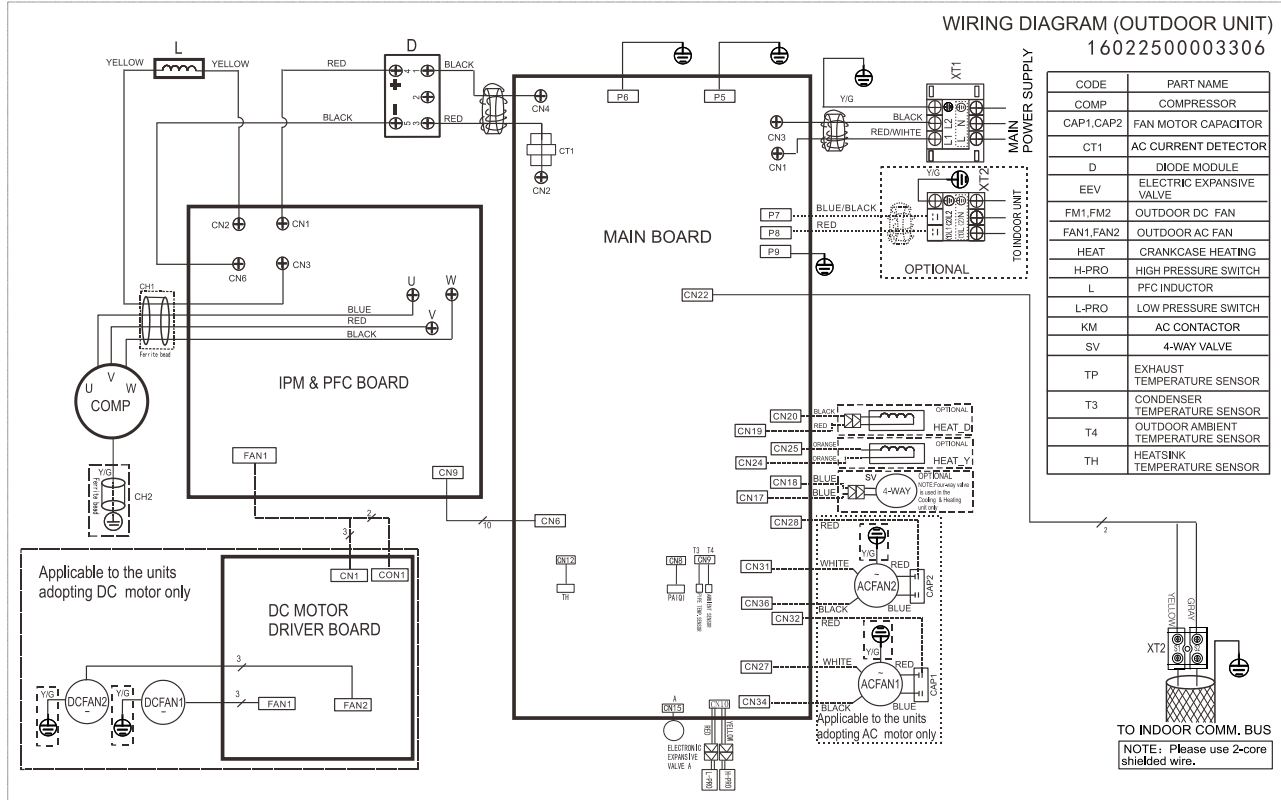

MOE30U-48HFN1-RRD0, MOE30U-55HFN1-RRD0

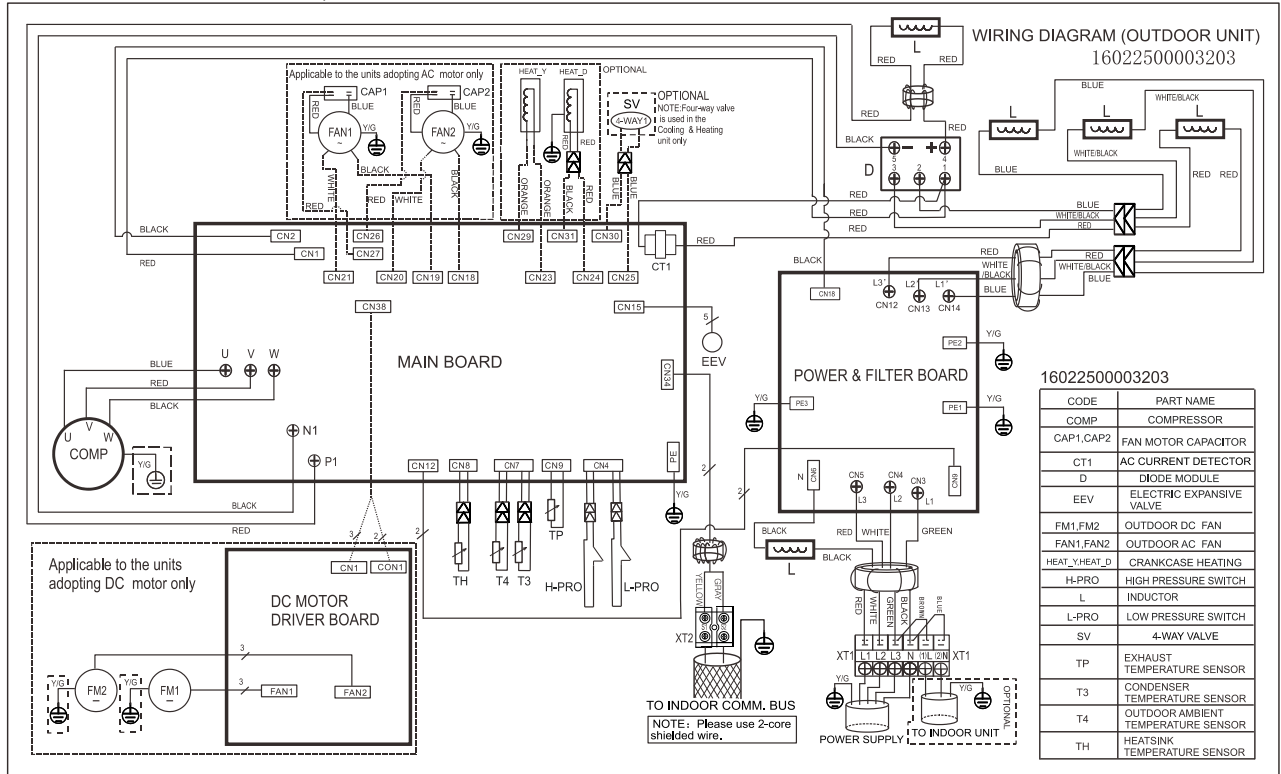

4. Piping Diagrams

MOB30U-12HFN1-QRD0W MOB30U-16HFN1-QRC8W MOB30U-18HFN1-QRD0
MOCA30U-24HFN1-QRD0

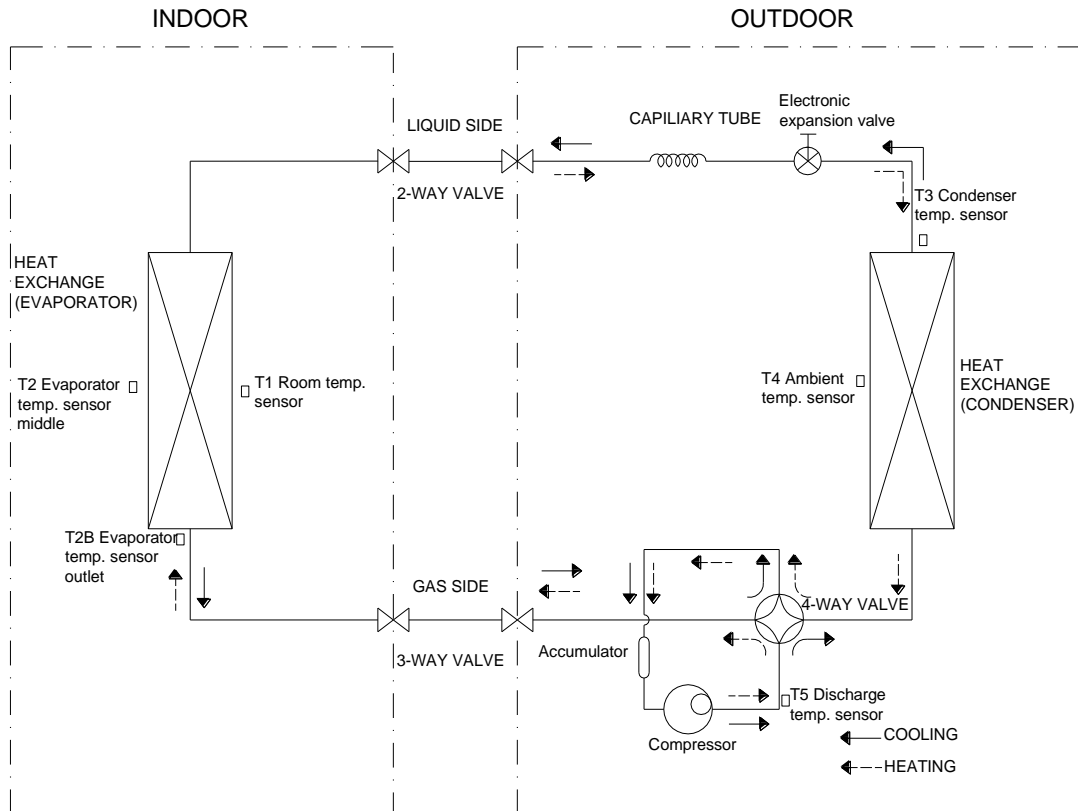

For MOCA30U-24HFN1-QRD0, there is no accumulator.

MOD30U-30HFN1-QRD0 MOD30U-36HFN1-QRD0 MOD30U-36HFN1-RRD0
MOD30U-42HFN1-QRD0 MOD30U-42HFN1-RRD0 MOE30U-48HFN1-QRD0
MOE30U-48HFN1-RRD0 MOE30U-55HFN1-RRD0

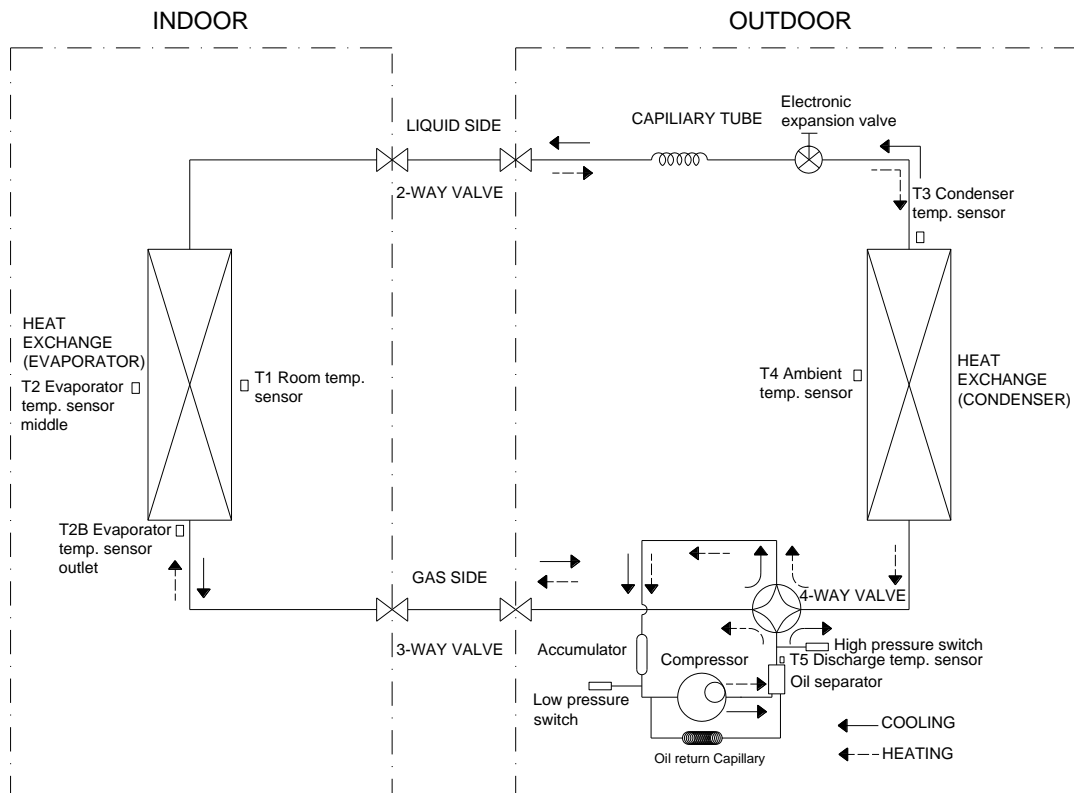

For MOD30U-30HFN1-QRD0, there are no oil separator and oil return capillary.

5. Electric Characteristics

Model	Outdoor Unit				Power Supply
	Hz	Voltage	Min.	Max.	MFA
MOB30U-12HFN1-QRD0W	50	220-240V	198V	254V	16
MOB30U-16HFN1-QRC8W	50	220-240V	198V	254V	20
MOB30U-18HFN1-QRD0	50	220-240V	198V	254V	20
MOCA30U-24HFN1-QRD0	50	220-240V	198V	254V	20
MOD30U-30HFN1-QRD0	50	220-240V	198V	254V	30
MOD30U-36HFN1-QRD0	50	220-240V	198V	254V	30
MOD30U-36HFN1-RRD0	50	380-415V	342V	440V	20
MOD30U-42HFN1-QRD0	50	220-240V	198V	254V	35
MOD30U-42HFN1-RRD0	50	380-415V	342V	440V	25
MOE30U-48HFN1-QRD0	50	220-240V	198V	254V	35
MOE30U-48HFN1-RRD0	50	380-415V	342V	440V	25
MOE30U-55HFN1-RRD0	50	380-415V	342V	440V	25

Notes:

MFA: Max. Fuse Amps. (A)

6. Operation Limits

Mode \ Temperature	Cooling operation	Heating operation	Drying operation
Room temperature	17°C ~ 32°C	0°C ~ 30°C	17°C ~ 32°C
Outdoor temperature	0°C ~ 50°C	-15°C ~ 24°C	0°C ~ 50°C
	(-15°C ~ 50°C : For the models with low temperature cooling system)		

CAUTION:

1. If the air conditioner is used beyond the above conditions, certain safety protection features may come into operation and cause the unit to operate abnormally.
2. The room relative humidity should be less than 80%. If the air conditioner operates beyond this figure, the surface of the air conditioner may attract condensation. Please set the vertical air flow louver to its maximum angle (vertically to the floor), and set HIGH fan mode.
3. The optimum performance will be achieved during this operating temperature zone.

7. Sound Levels

Outdoor Unit

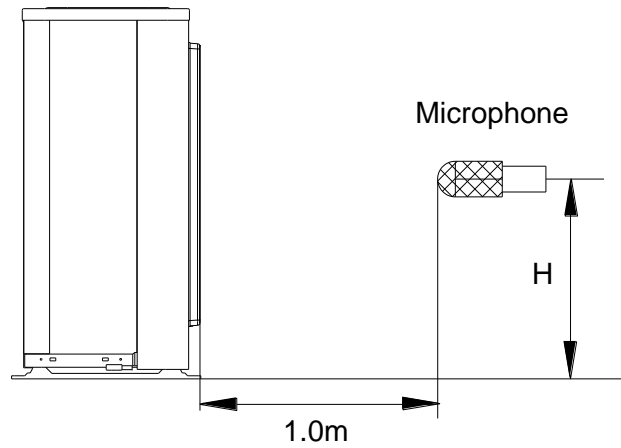

Note: H= 0.5 × height of outdoor unit

Model	Noise Power dB(A)	Noise level dB(A)
MOB30U-12HFN1-QRD0W	60	57
MOB30U-16HFN1-QRC8W	63	56.5
MOB30U-18HFN1-QRD0	64	56.5
MOCA30U-24HFN1-QRD0	65	60.5
MOD30U-30HFN1-QRD0	66	59.5
MOD30U-36HFN1-QRD0	66	61
MOD30U-36HFN1-RRD0	67	62
MOD30U-42HFN1-QRD0	71	62.5
MOD30U-42HFN1-RRD0	71	63
MOE30U-48HFN1-QRD0	72	65
MOE30U-48HFN1-RRD0	72	65
MOE30U-55HFN1-RRD0	75	62.5

Part 4

Installation

1. Installation Procedure	108
2. Location selection	109
3. Indoor unit installation	110
4. Outdoor unit installation (Side Discharge Unit).....	128
5. Refrigerant pipe installation.....	129
6. Drainage pipe installation	133
7. Vacuum Drying and Leakage Checking	137
8. Additional refrigerant charge.....	138
9. Engineering of insulation.....	139
10. Engineering of electrical wiring.....	140
11. Test operation	141

1. Installation Procedure

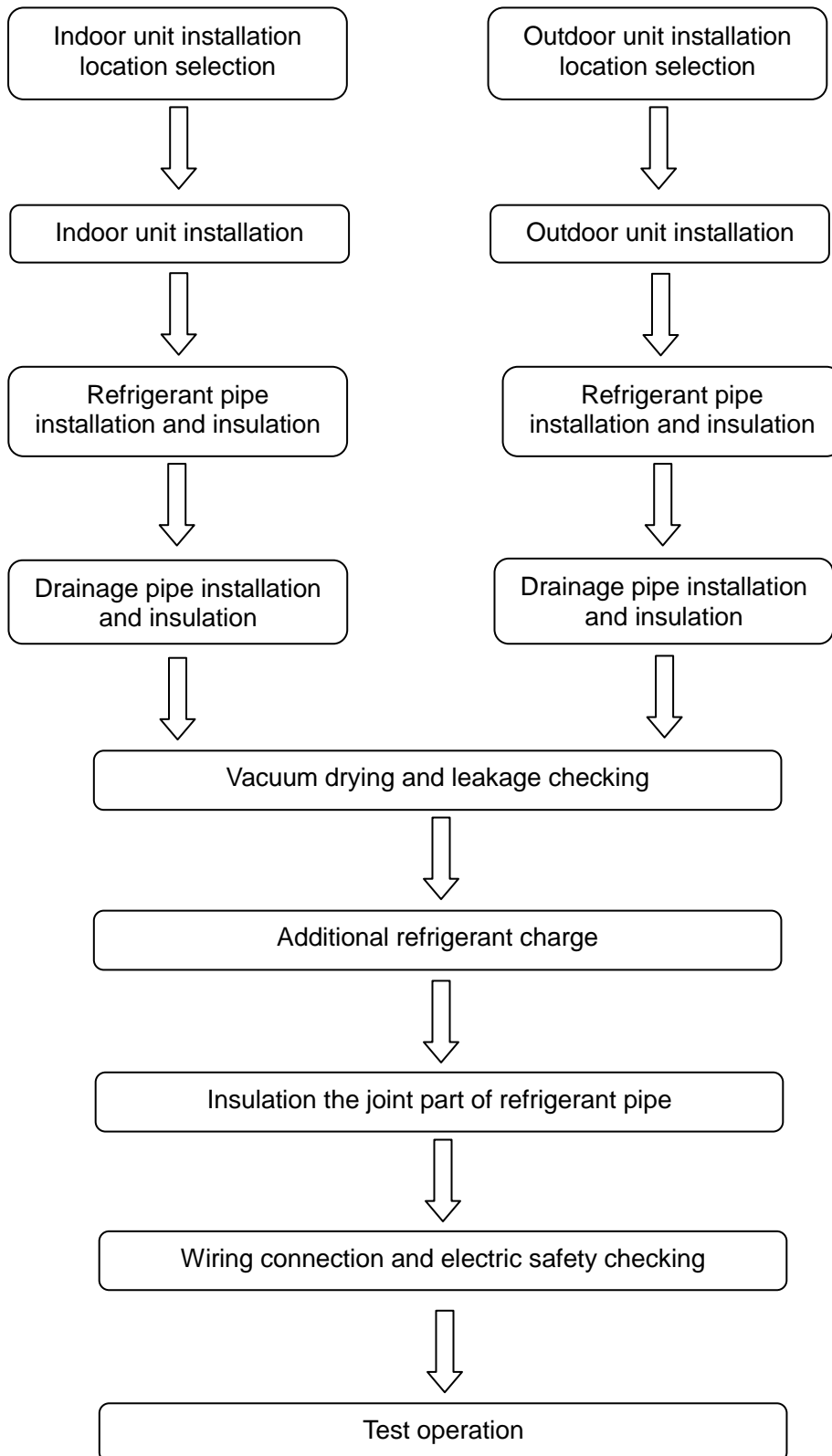

2. Location selection

2.1 Indoor unit location selection

- The place shall easily support the indoor unit's weight.
- The place can ensure the indoor unit installation and inspection.
- The place can ensure the indoor unit horizontally installed.
- The place shall allow easy water drainage.
- The place shall easily connect with the outdoor unit.
- The place where air circulation in the room should be good.
- There should not be any heat source or steam near the unit.
- There should not be any oil gas near the unit
- There should not be any corrosive gas near the unit
- There should not be any salty air near the unit
- There should not be strong electromagnetic wave near the unit
- There should not be inflammable materials or gas near the unit
- There should not be strong voltage vibration.

2.2 Outdoor unit location selection

- The place shall easily support the outdoor unit's weight.
- Locate the outdoor unit as close to indoor unit as possible
- The piping length and height drop can not exceed the allowable value.
- The place where the noise, vibration and outlet air do not disturb the neighbors.
- There is enough room for installation and maintenance.
- The air outlet and the air inlet are not impeded, and not face the strong wind.
- It is easy to install the connecting pipes and cables.
- There is no danger of fire due to leakage of inflammable gas.
- It should be a dry and well ventilation place
- The support should be flat and horizontal
- Do not install the outdoor unit in a dirty or severely polluted place, so as to avoid blockage of the heat exchanger in the outdoor unit.
- If is built over the unit to prevent direct sunlight, rain exposure, direct strong wind, snow and other scraps accumulation, make sure that heat radiation from the condenser is not restricted.

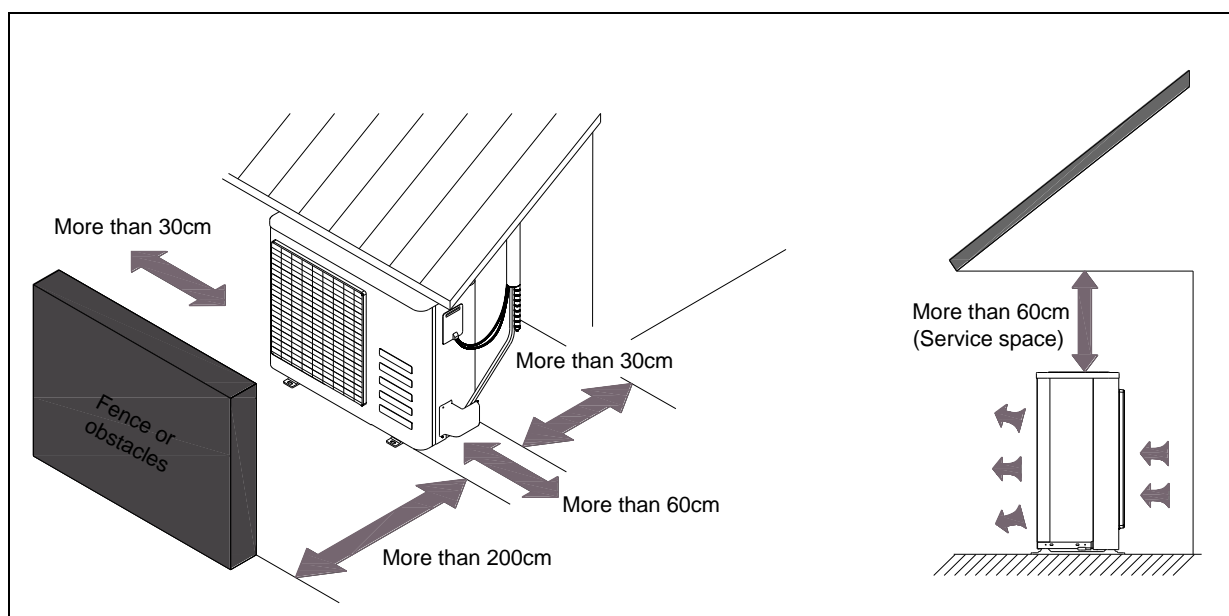

3. Indoor unit installation

3.1 Super slim cassette indoor unit installation

3.1.1 Service space for indoor unit

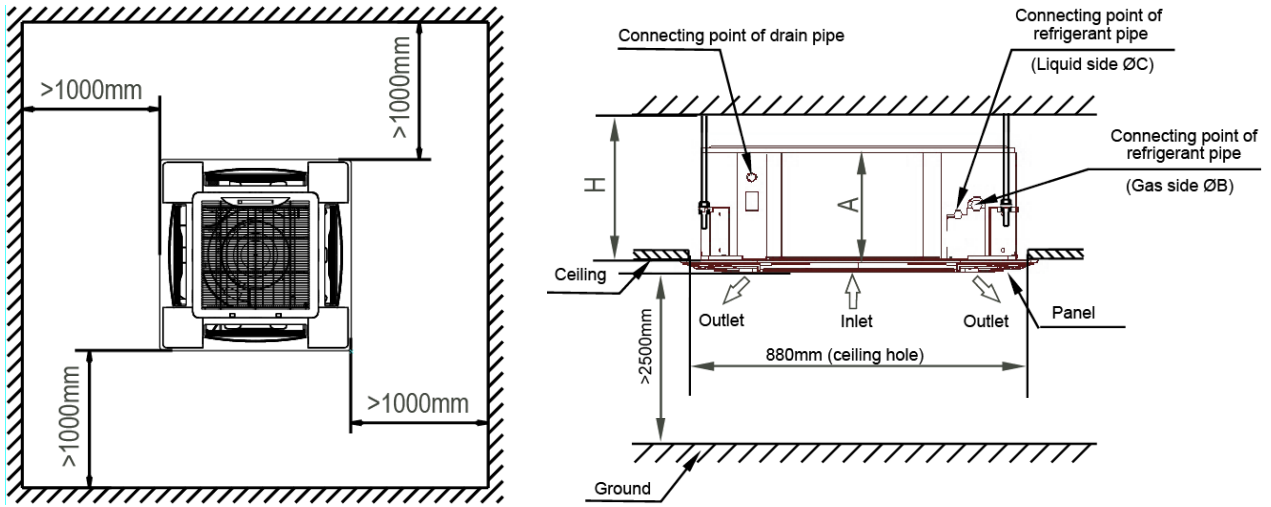

Model	A	H
18	205	>235
24~42	245	>275
48/55	287	>317

3.1.2 Bolt pitch

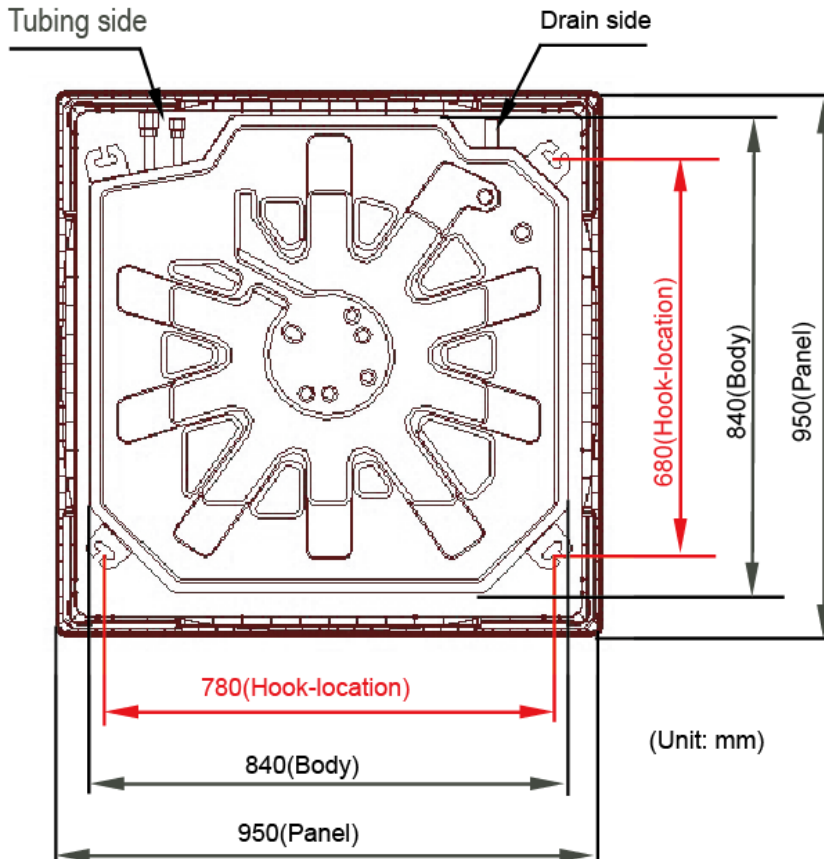

3.1.3 Install the pendant bolt

Select the position of installation hooks according to the hook holes positions showed in upper picture. Drill four holes of $\text{Ø}12\text{mm}$, 45~50mm deep at the selected positions on the ceiling. Then embed the expansible hooks (fittings).



3.1.4 Install the main body

Make the 4 suspender through the 4 hanger of the main body to suspend it. Adjust the hexangular nuts on the four installation hooks evenly, to ensure the balance of the body. Use a leveling instrument to make sure the levelness of the main body is within $\pm 1^\circ$.



Adjust the position to ensure the gaps between the body and the four sides of ceiling are even. The body's lower part should sink into the ceiling for 10~12 mm. In general, L is half of the screw length of the installation hook.

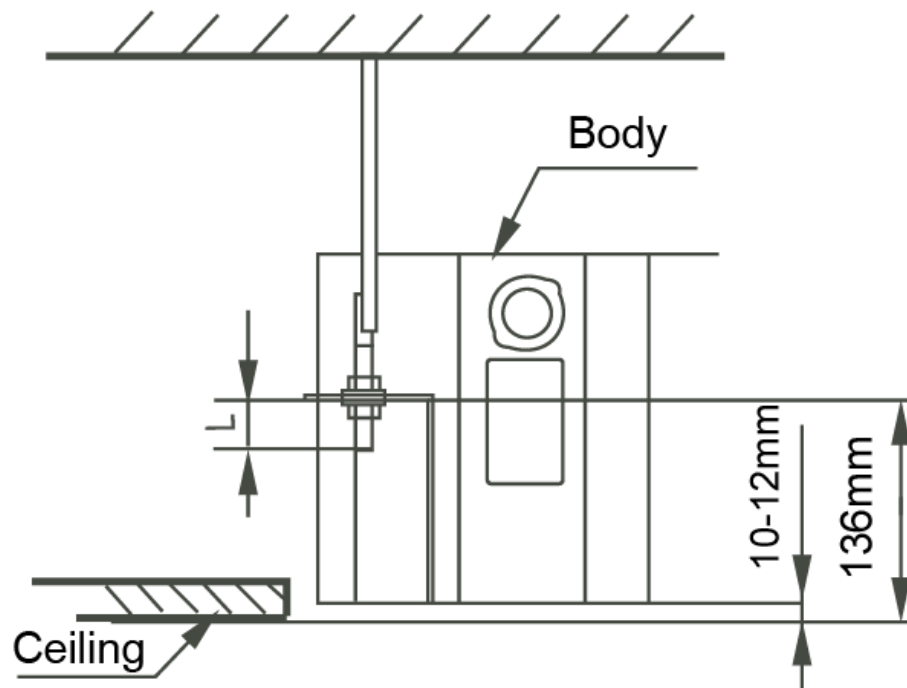

Locate the air conditioner firmly by wrenching the nuts after having adjusted the body's position well.

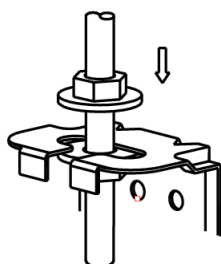

3.1.5 Install the panel

Remove the grille

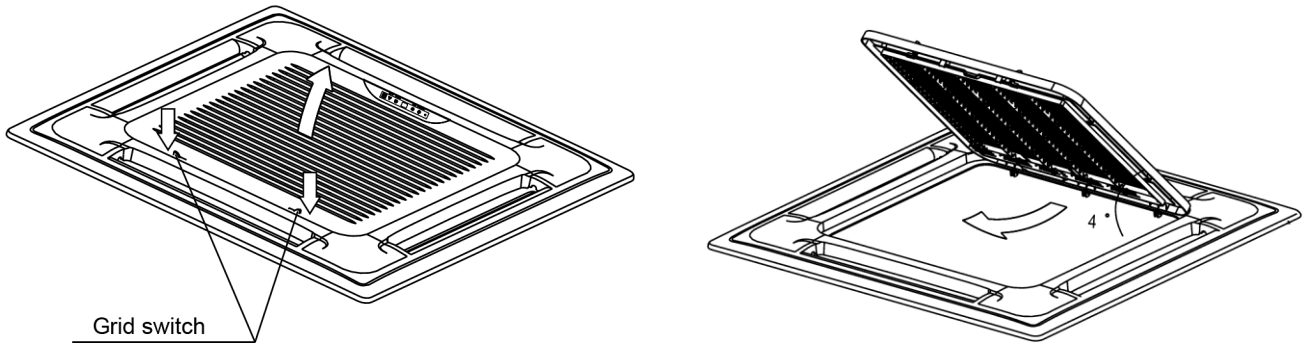

Remove the 4 corner covers.

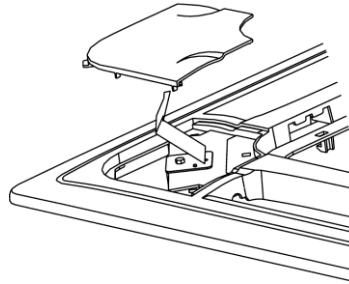

Hang the panel to the hooks on the mainbody. If the panel is with auto-lift grille, please watch the ropes lifing the grille, DO NOT make the ropes enwinded or blocked.

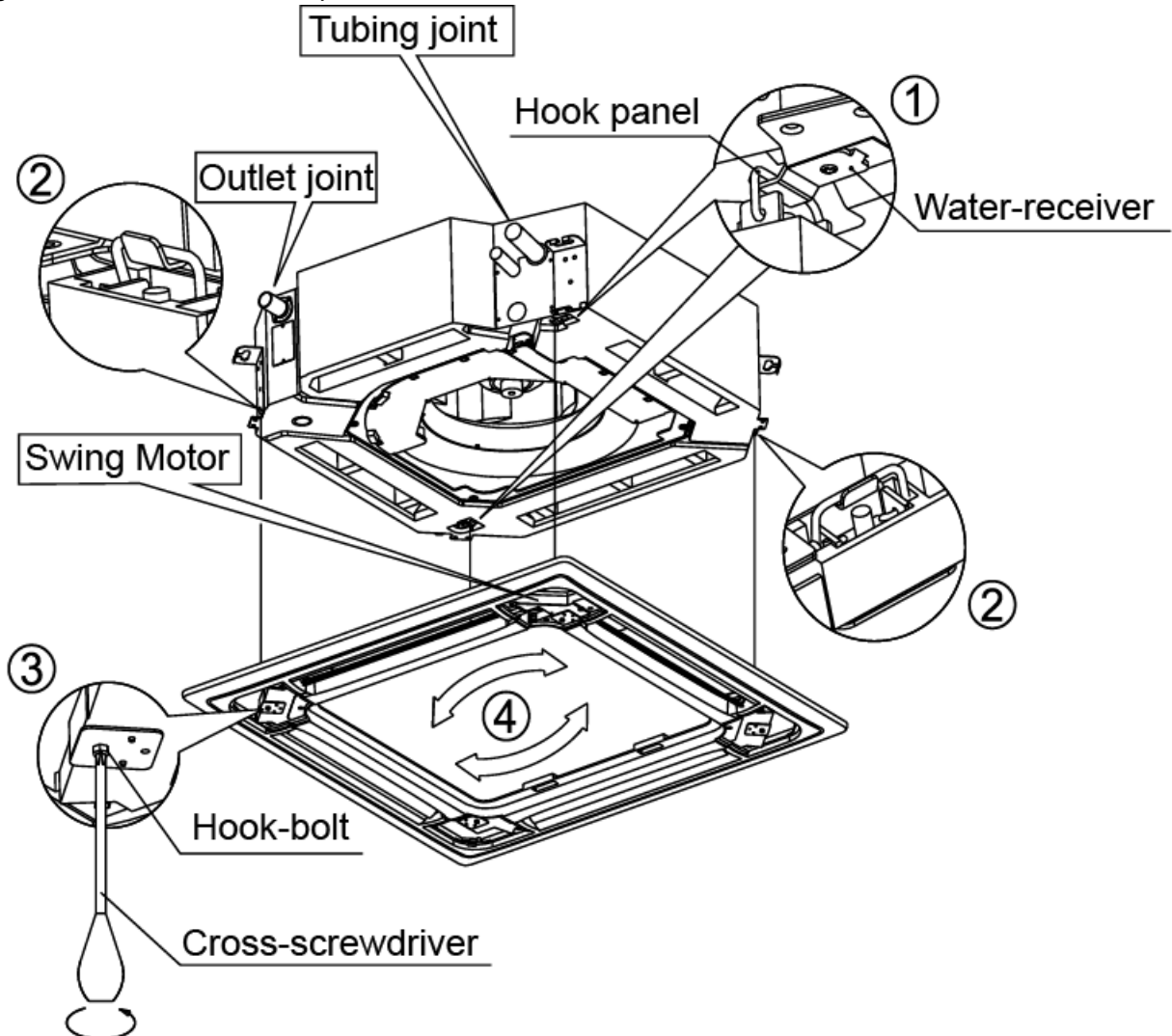

Tighten the screws under the panel hooks till the panel closely stick on the ceiling to avoid condensate water.

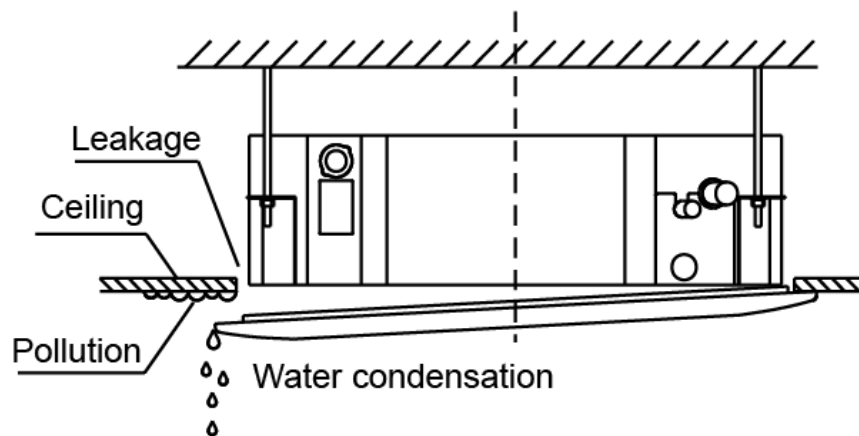
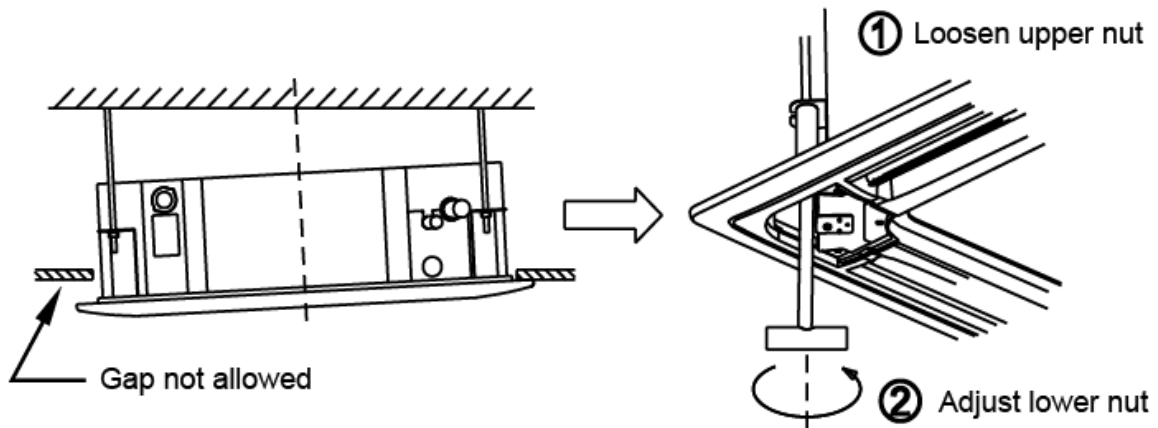

Hang the air-in grill to the panel, then connect the lead terminator of the swing motor and that of the control box with corresponding terminators on the body respectively.

Install the 4 corner covers back.

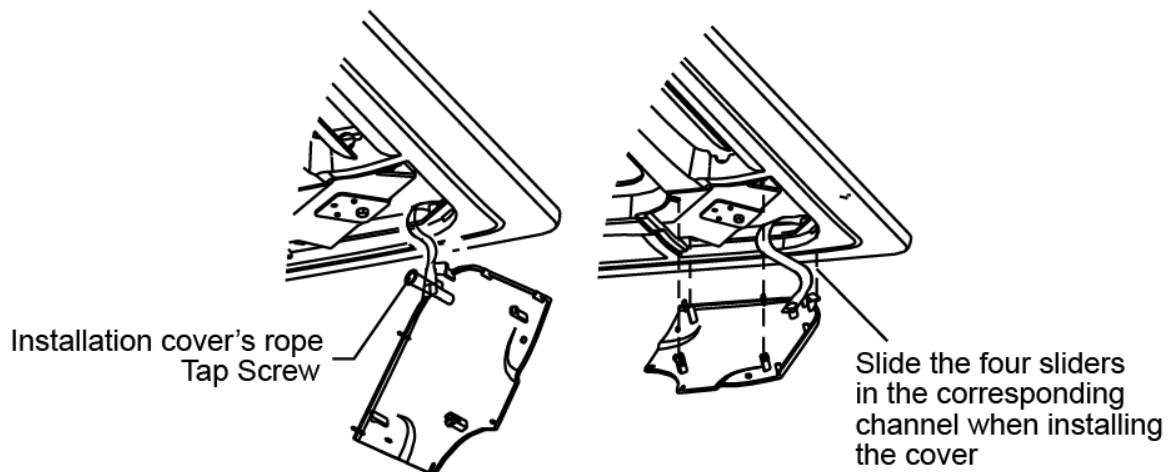

Note: The panel shall be installed after the wiring connected.

3.2 A5 duct indoor unit installation

3.2.1 Service space for indoor unit

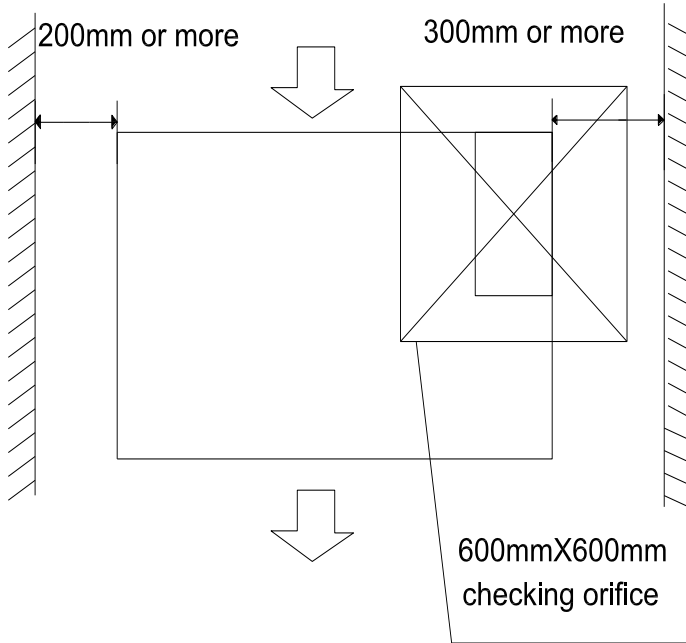

3.2.2 Bolt pitch

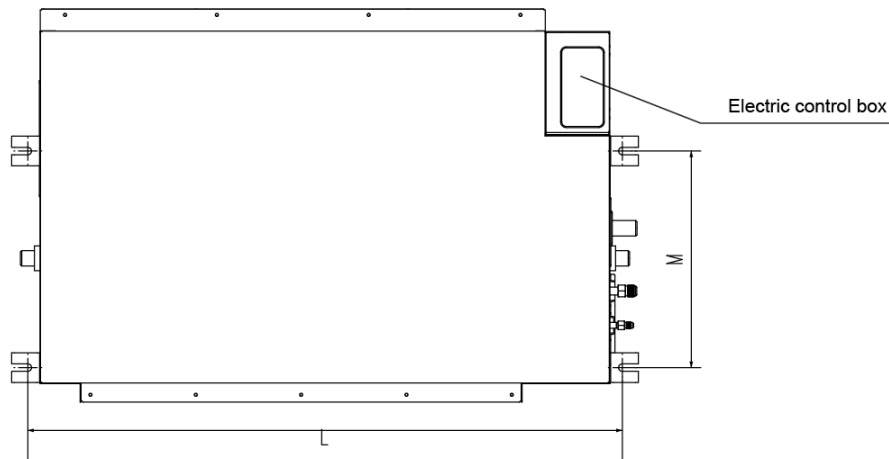

Capacity(KBtu)	Size of outline dimension mounted plug	
	L	M
12	740	350
18/24	960	350
30	1240	500
36-60	1240	500

3.2.3 Install the pendant bolt

Select the position of installation hooks according to the hook holes positions showed in upper picture. Drill four holes of $\text{Ø}12\text{mm}$, 45~50mm deep at the selected positions on the ceiling. Then embed the expansible hooks (fittings).



3.2.4 Install the main body

Make the 4 suspender through the 4 hanger of the main body to suspend it. Adjust the hexangular nuts on the four installation hooks evenly, to ensure the balance of the body. Use a leveling instrument to make sure the levelness of the main body is within $\pm 1^\circ$.

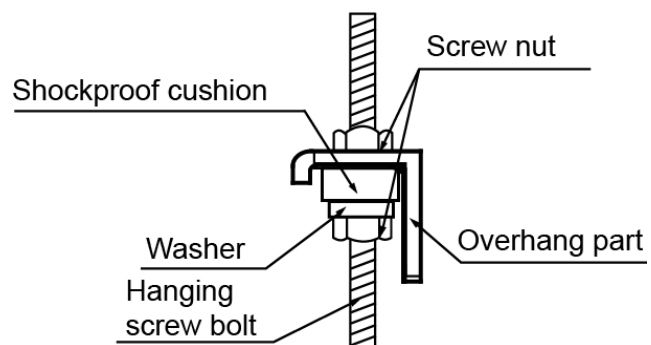

3.2.5 Install the air filter

Insert the air filter through the filter slot and fix it with 2 screws.

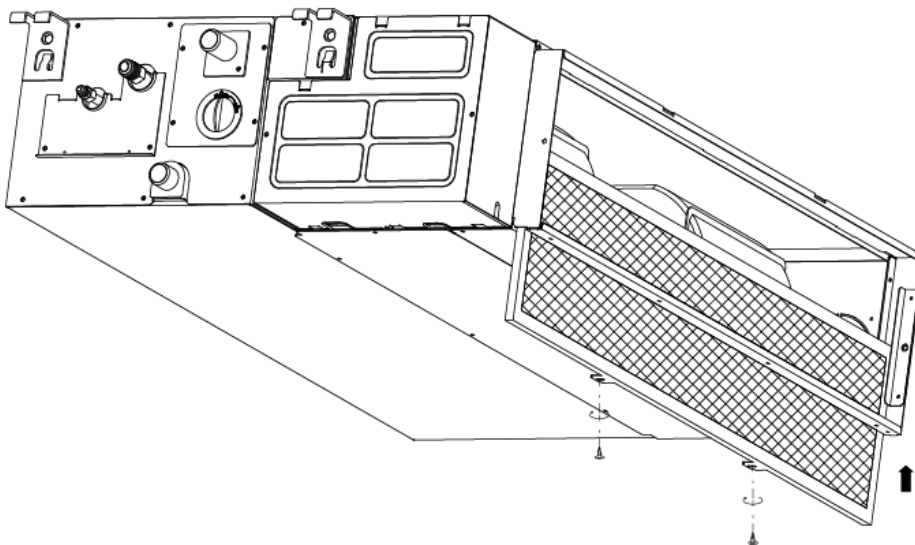

3.2.6 Install the air duct

Please design the air duct as below recommended picture

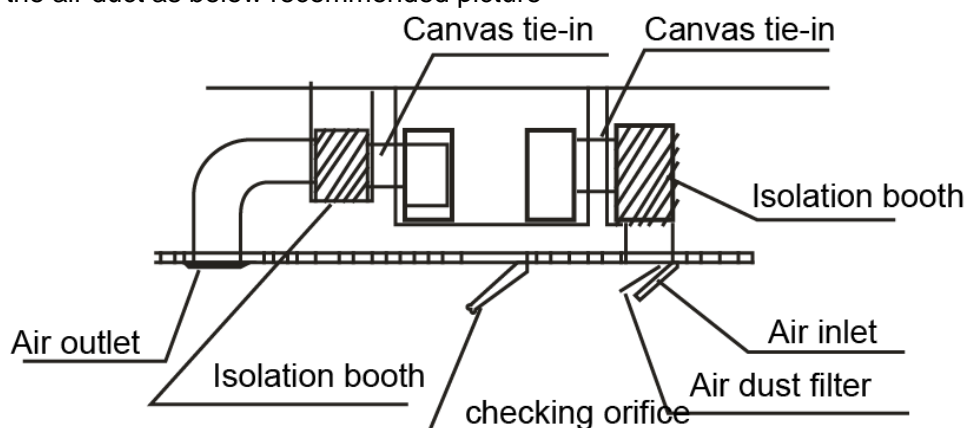

3.2.7 Change the air inlet direction

- ① Take off ventilation panel and flange, cut off the staples at side rail.

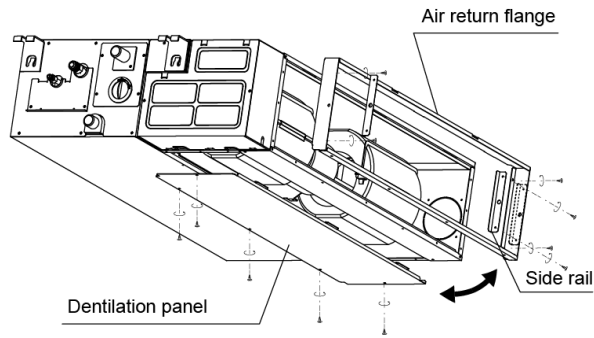

- ② Stick the attached seal sponge as per the indicating place in the following fig, and then change the mounting positions of air return panel and air return flange .

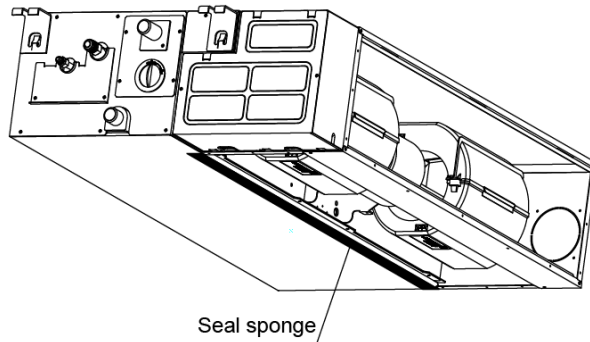

- ③ When install the filter mesh, please plug it into flange inclined from air return opening, and then push up.

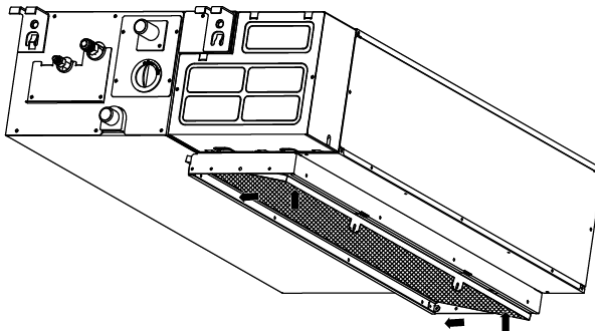

- ④ The installation has finish, upon filter mesh which fixing blocks have been insert to the flange positional holes.

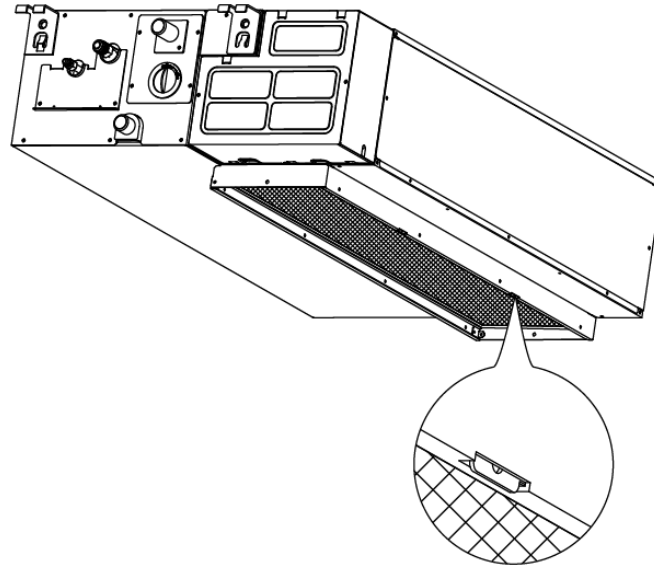

3.3 Ceiling & floor indoor unit installation

3.3.1 Service space for indoor unit

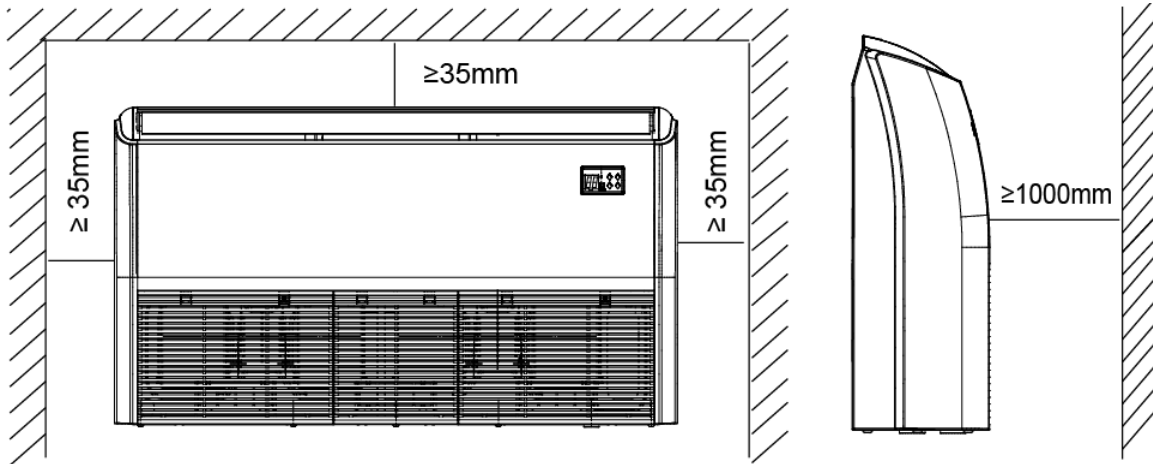

3.3.2 Bolt pitch

① Ceiling installation

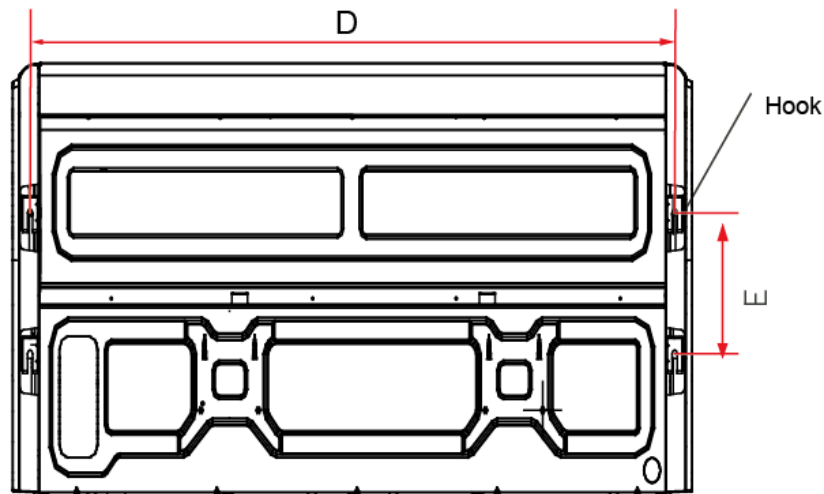

Capacity (KBtu/h)	D	E
18/24	983	220
30K	1200	220
36-60	1565	220

② Wall-mounted installation

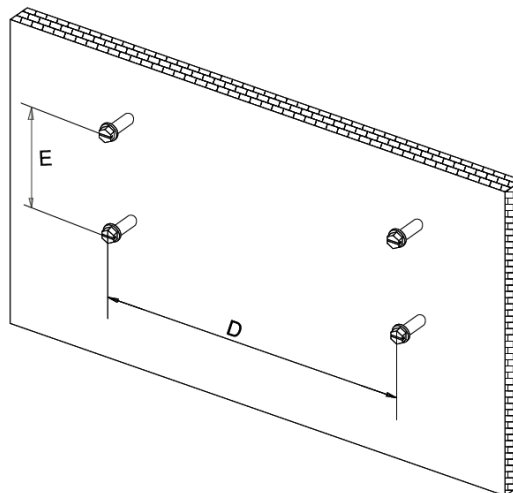

3.3.3 Install the pendant bolt

① Ceiling installation

Select the position of installation hooks according to the hook holes positions showed in upper picture.

Drill four holes of $\varnothing 12\text{mm}$, 45~50mm deep at the selected positions on the ceiling. Then embed the expansible hooks (fittings).



② Wall-mounted installation

Install the tapping screws onto the wall. (Refer to picture below)

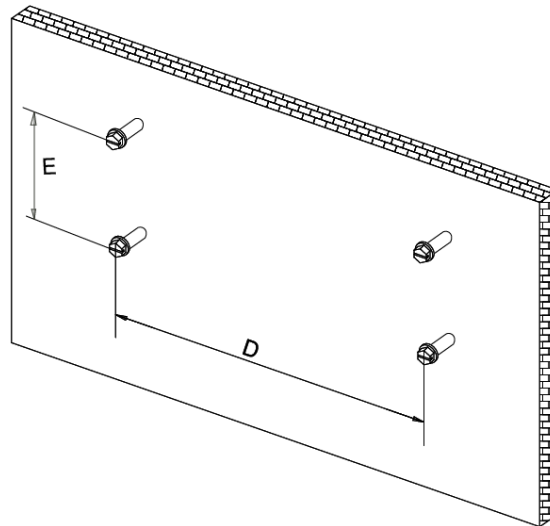

3.3.4 Install the main body

① Ceiling installation (The only installation method for the unit with drain pump)

Remove the side board and the grille.

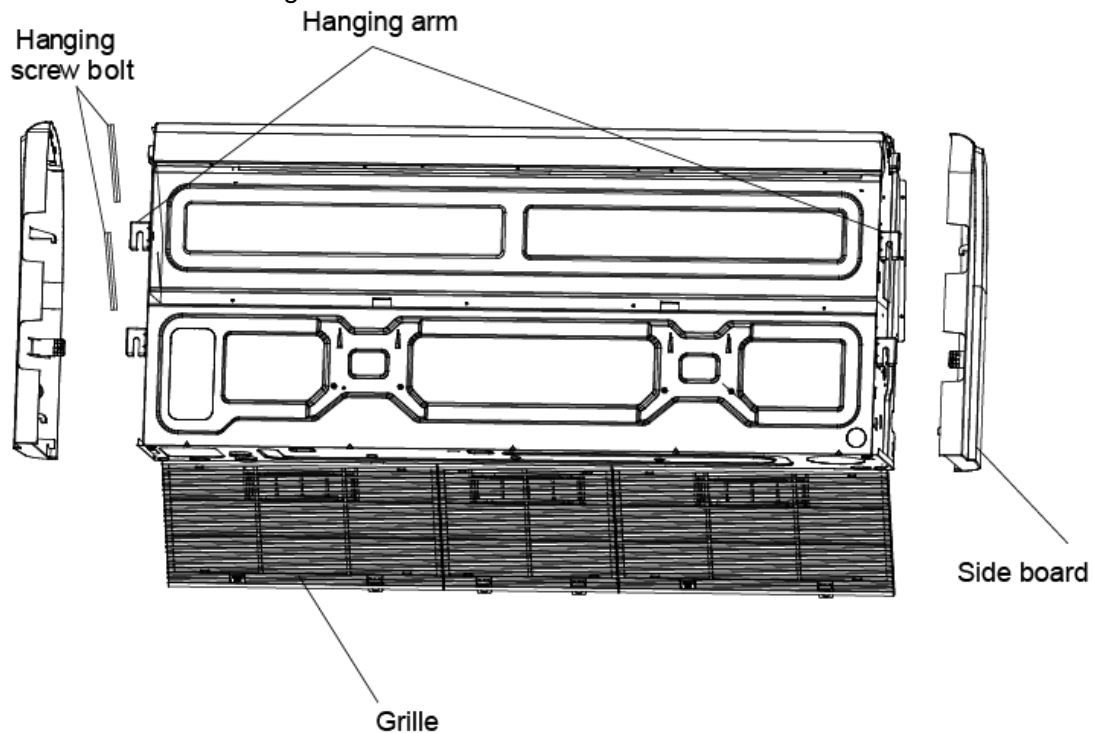

Locate the hanging arm on the hanging screw bolt. Prepare the mounting bolts on the unit.

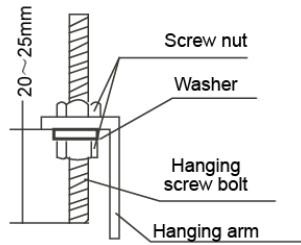

Put the side panels and grilles back.

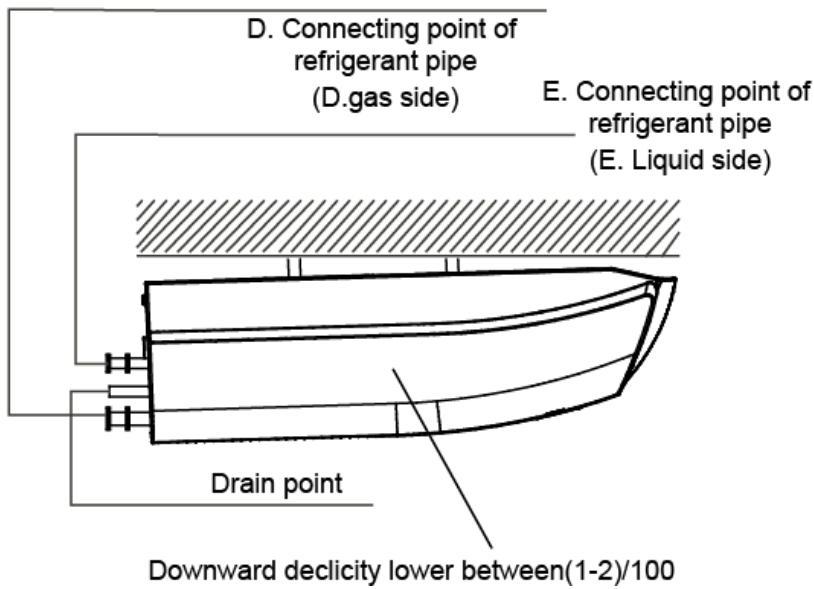
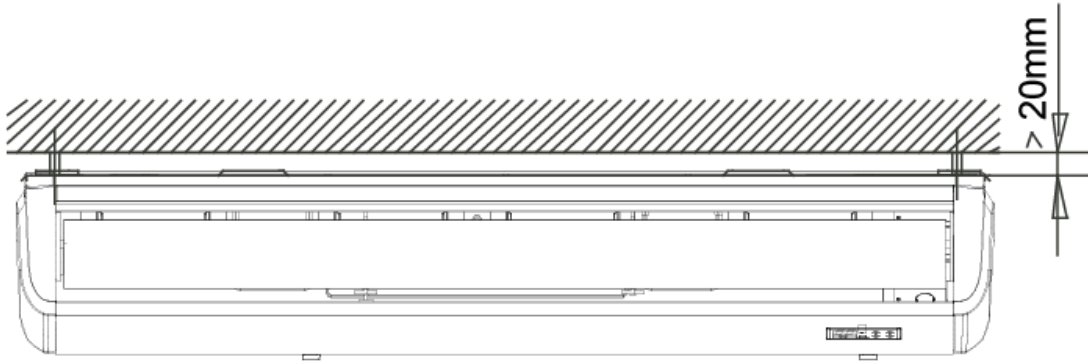

② Wall-mounted installation

Hang the indoor unit by insert the tapping screws into the hanging arms on the main unit. (The bottom of body can touch with floor or suspended, but the body must install vertically.)

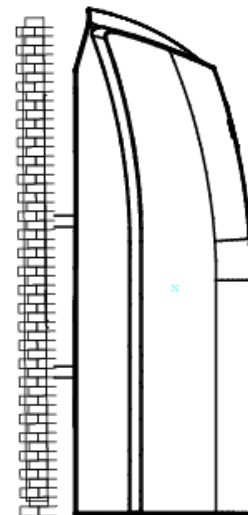
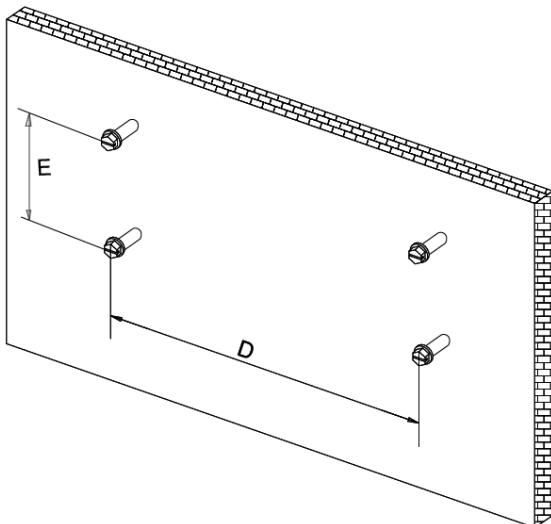

3.4 Compact cassette indoor unit installation

3.4.1 Service space for indoor unit

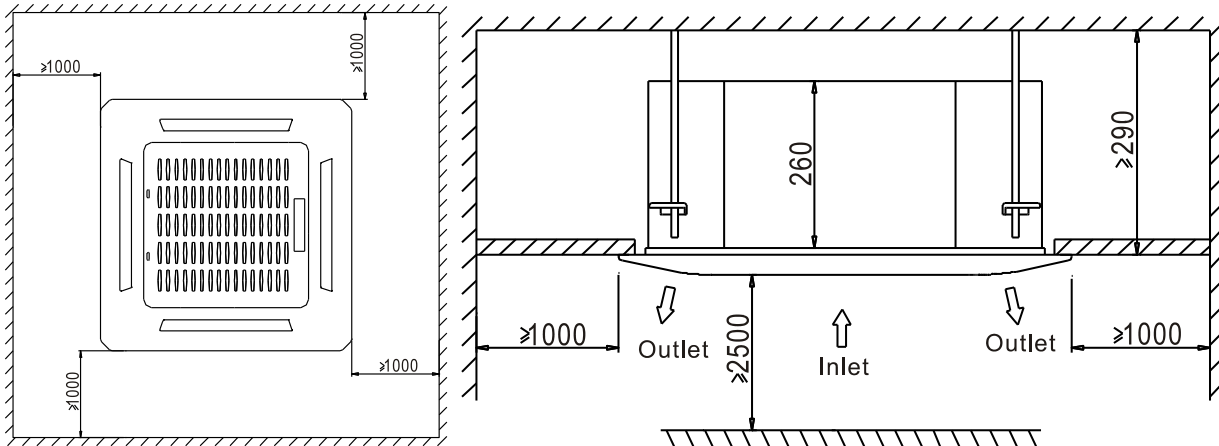

3.4.2 Bolt pitch

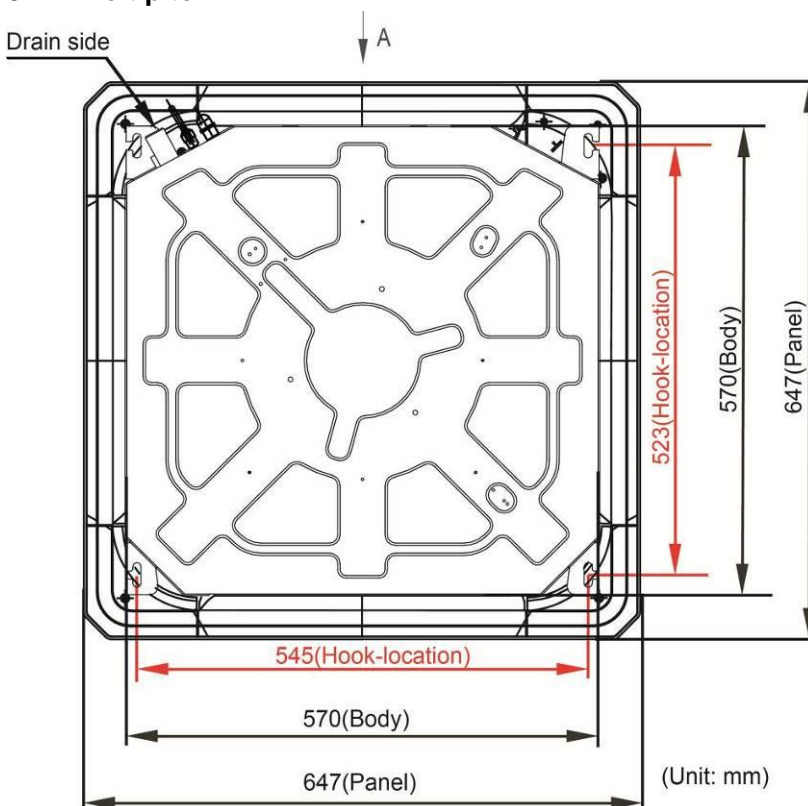

3.4.3 Install the pendant bolt

Select the position of installation hooks according to the hook holes positions showed in upper picture. Drill four holes of $\text{Ø}12\text{mm}$, 45~50mm deep at the selected positions on the ceiling. Then embed the expansible hooks (fittings).



Face the concave side of the installation hooks toward the expansible hooks. Determine the length of the installation hooks from the height of ceiling, then cut off the unnecessary part.

If the ceiling is extremely high, please determine the length of the installation hook depending on the real situation.

3.4.4 Install the main body

Make the 4 suspender through the 4 hanger of the main body to suspend it. Adjust the hexangular nuts on the four installation hooks evenly, to ensure the balance of the body. Use a leveling instrument to make sure the levelness of the main body is within $\pm 1^\circ$.

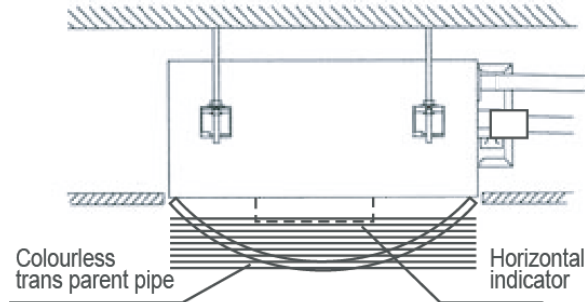

Adjust the position to ensure the gaps between the body and the four sides of ceiling are even. The body's lower part should sink into the ceiling for 10~12 mm. In general, L is half of the screw length of the installation hook.

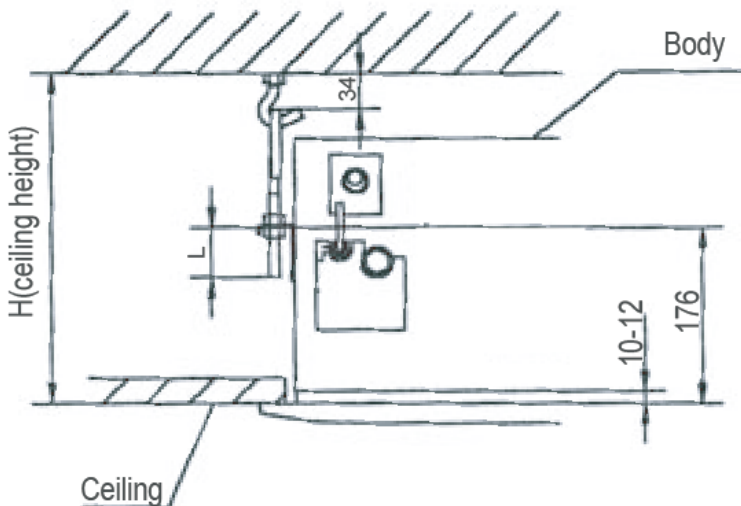

Locate the air conditioner firmly by wrenching the nuts after having adjusted the body's position well.



3.4.5 Install the panel

Remove the grille

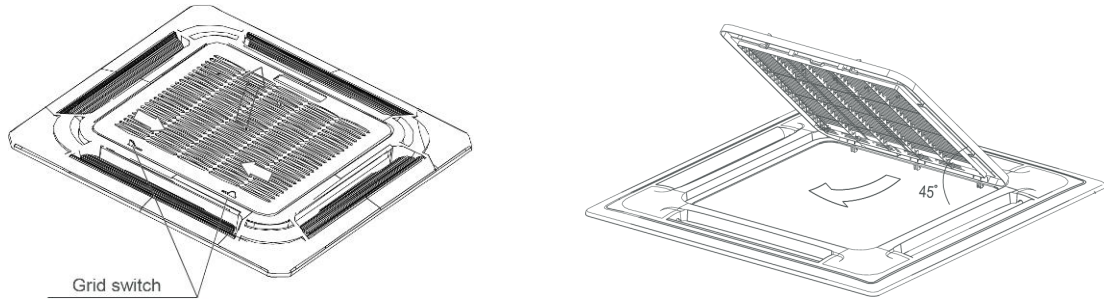

Hang the panel to the hooks on the mainbody.

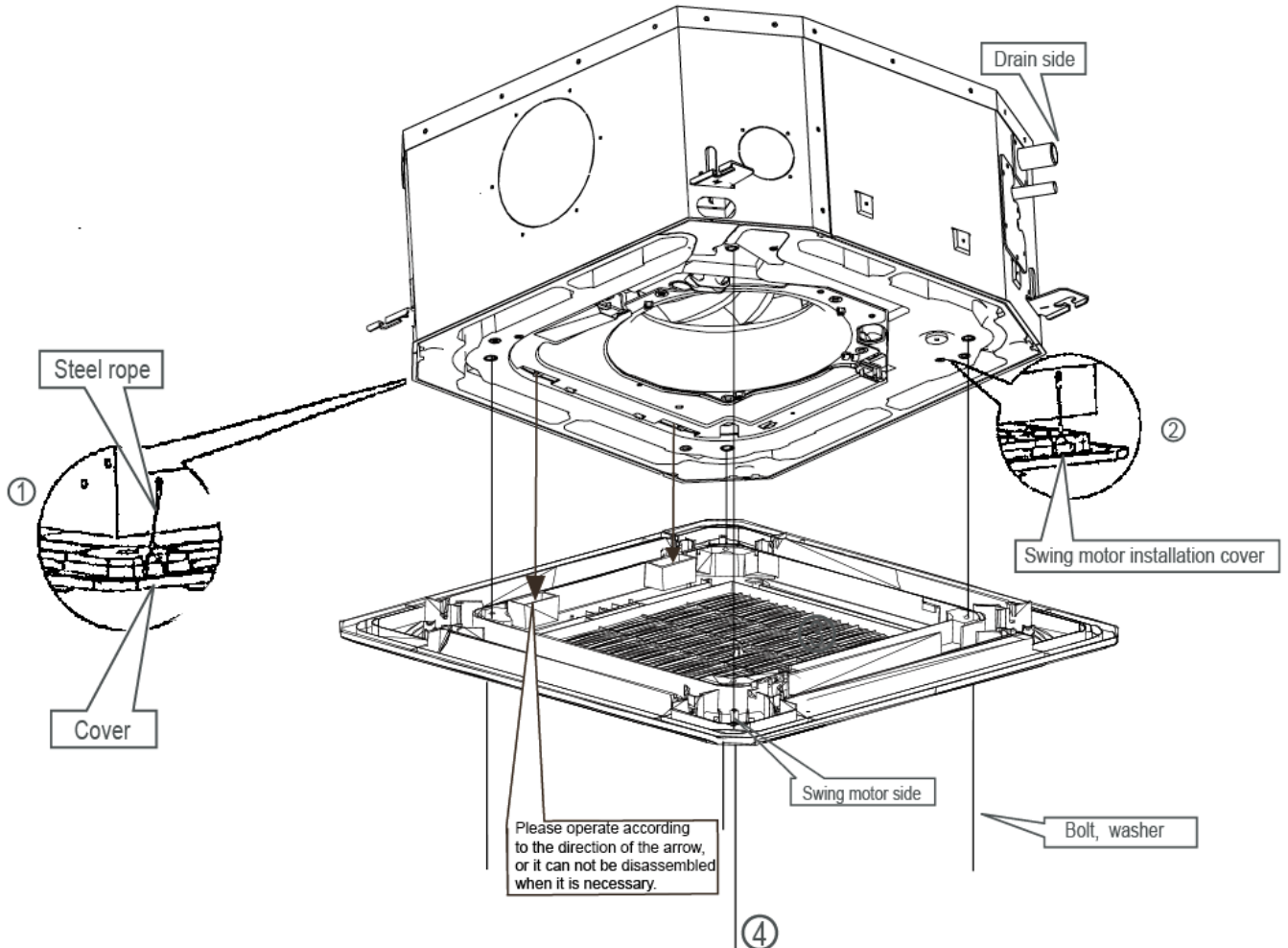

Tighten the screws under the panel hooks till the panel closely stick on the ceiling to avoid condensate water.

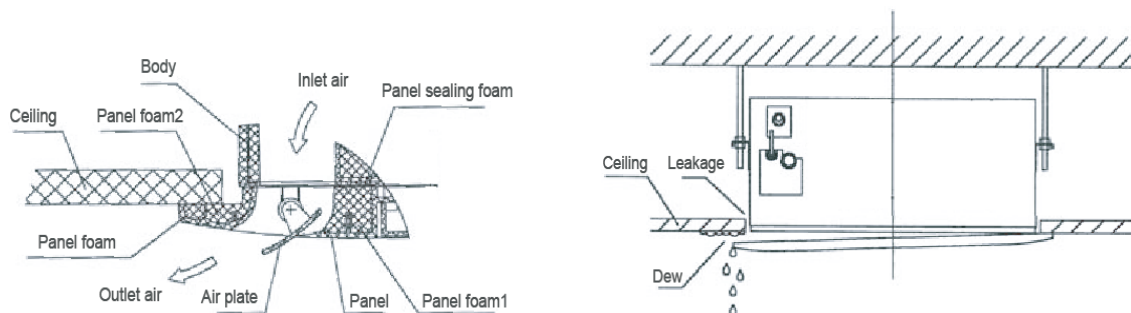

Hang the air-in grill to the panel, then connect the lead terminator of the swing motor and that of the control box with corresponding terminators on the body respectively.

Note: The panel shall be installed after the wiring connected.

3.5 Console indoor unit installation

3.7.7 Service space for indoor unit

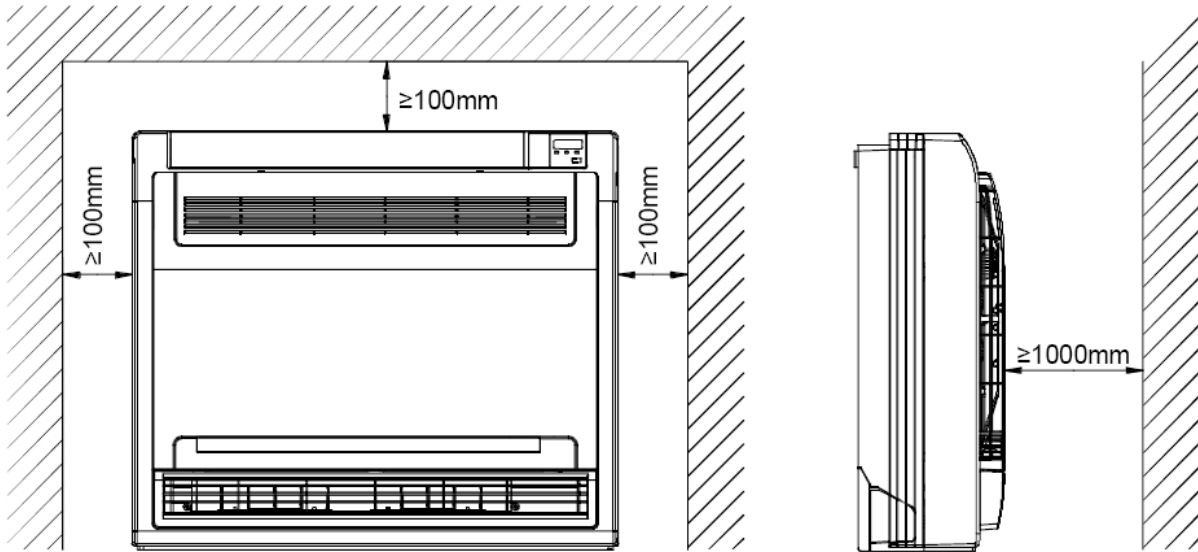

3.7.8 Install the main body

- Fix the hook with tapping screw onto the wall

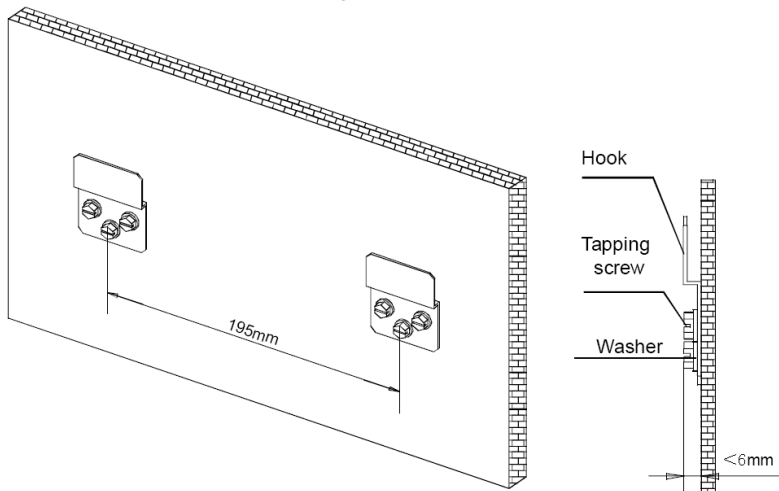

- Hang the indoor unit on the hook.
(The bottom of body can touch with floor or suspended, but the body must install vertically.)

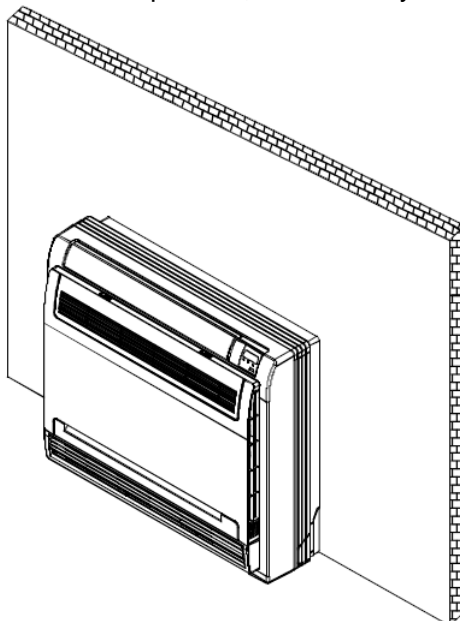

3.6 GA floor standing indoor unit installation

3.6.1 Service space for indoor unit

- A place which provides the spaces around the indoor unit as required above in the diagram.
- A place where is no obstacle near the inlet and outlet area.
- A place which can bear the weight of the indoor unit.
- A place which allows the air filter to be removed downward.
- A place where the reception range is not exposed to direct sunlight.
- In the center of the room where possible.

- 3.6.1.1 Please stand the unit in hard and flat ground;
Please reserve space for installation and maintenance.

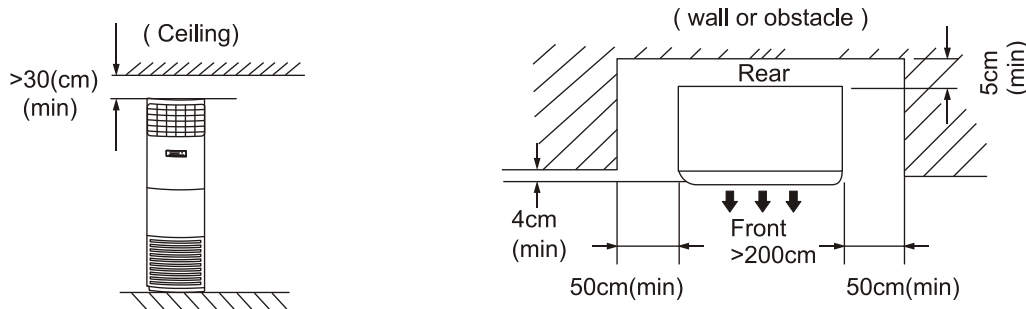

3.6.2 Installing

3.6.2.1. Anti-falling;

To prevent the indoor unit from falling, you must:

- Pay full attention to the unit because its long outer shape makes it easy to fall;
- Firmly fix the unit to the wall or in the ground to avoid accidental falling.

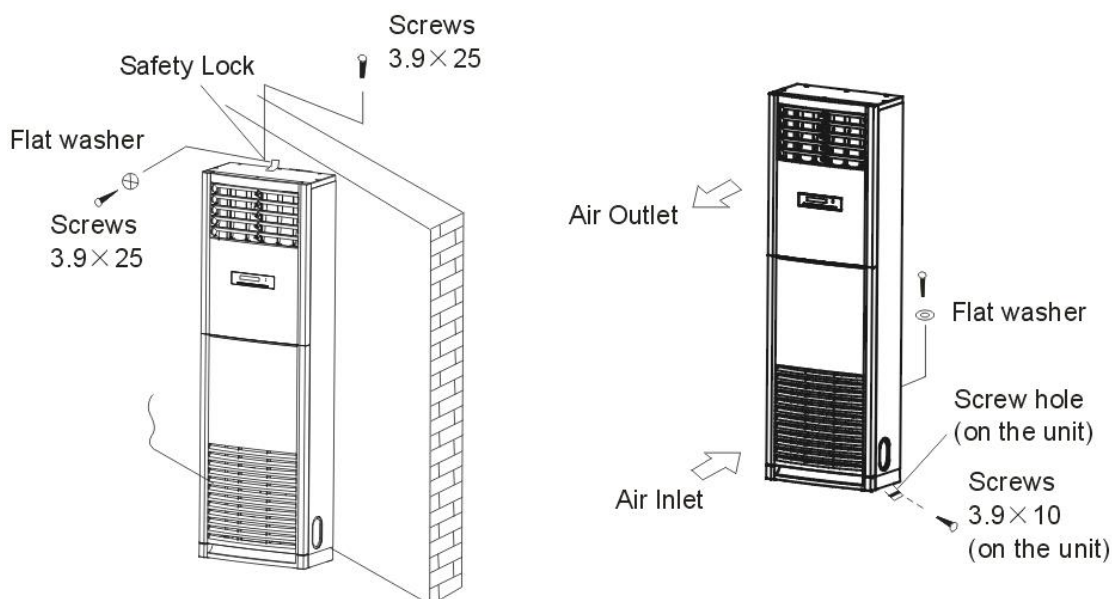

3.6.2.2. Dismounting the lower front panel

Please take off the air-inlet grid before connecting the pipes/wires.

Pull down the two knobs on the grille, take off the two screws, then the air-inlet grille goes free.

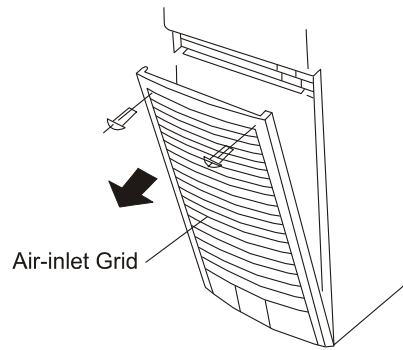

3.6.2.3. Take the Pipe Clip off before connecting the pipes and wiring; fit it when these finished.
Use accessories to connect the pipes/wires on both sides and back side.

Pipe/wire-hole position on back side

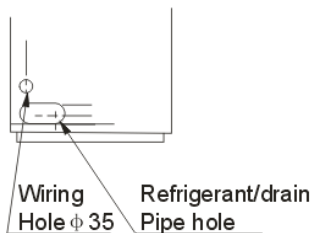

Pipe/wire-hole position on the bottom

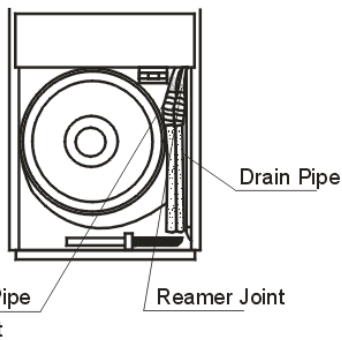
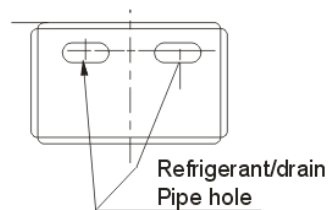

Pipe/wire-hole positions on both sides

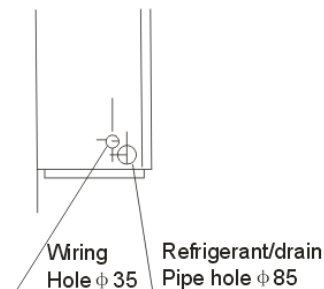

3.7 M floor standing indoor unit installation

3.7.1 Service space for indoor unit

- A place which provides the spaces around the indoor unit as required above in the diagram.
- A place where is no obstacle near the inlet and outlet area.
- A place which can bear the weight of the indoor unit.
- A place which allows the air filter to be removed downward.
- A place where the reception range is not exposed to direct sunlight.
- In the center of the room where possible.

3.7.1.1 Please stand the unit in hard and flat ground;
Please reserve space for installation and maintenance.

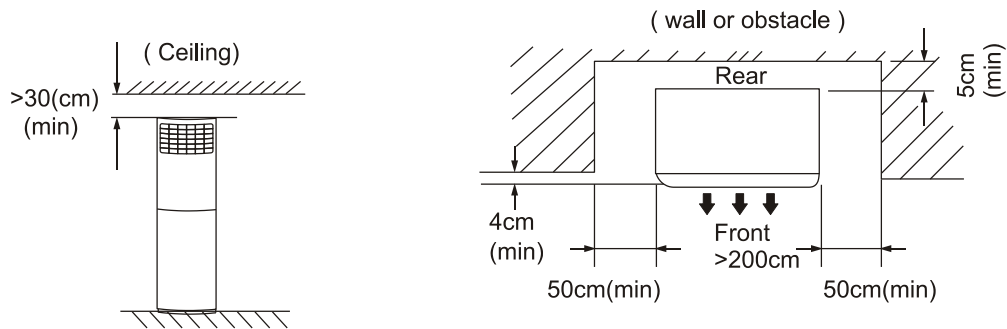

3.7.2 Installing

3.7.2.1. Anti-falling;

To prevent the indoor unit from falling, you must:

- Pay full attention to the unit because its long outer shape makes it easy to fall;
- Firmly fix the unit to the wall or in the ground to avoid accidental falling.

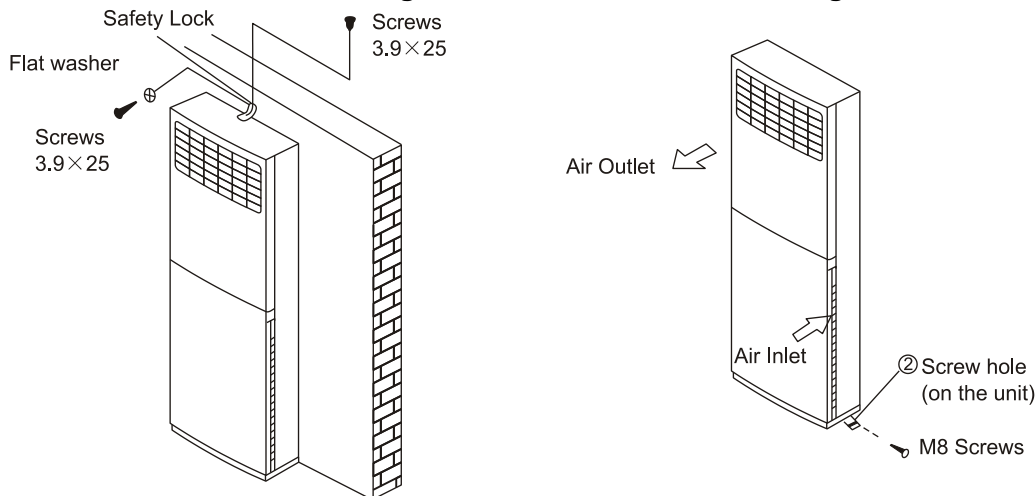

3.7.2.2. Dismounting the air-inlet grid

Please take off the air-inlet grid before connecting the pipes/wires.

The grid is hitched by a loop inside. To dismount the air-inlet grid, hold both sides of the grid and pull it up, let it slant downwards until the loop become straight. Then removing the screws fastened the loop with the grid, and the grid goes free.

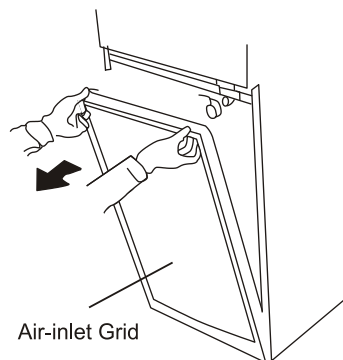

3.7.2.3. Take the Pipe Clip off before connecting the pipes and wiring; fit it when these finished.

Use accessories to connect the pipes/wires on both sides and back side.

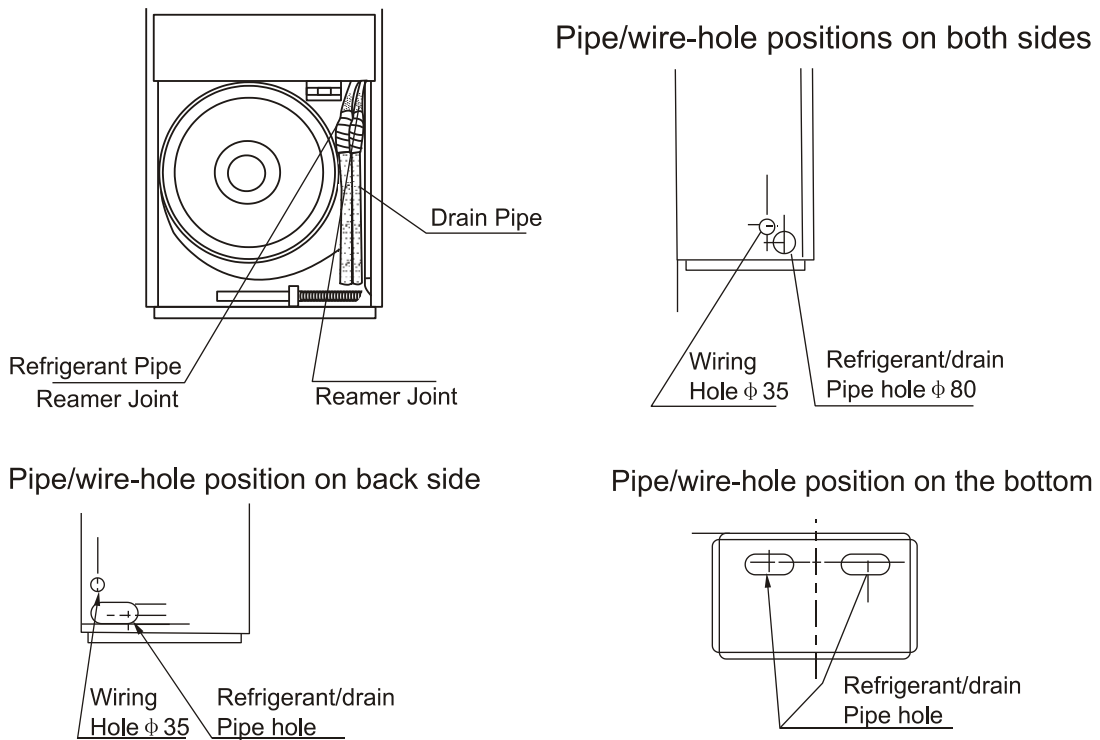

4. Outdoor unit installation (Side Discharge Unit)

4.1 Service space for outdoor unit

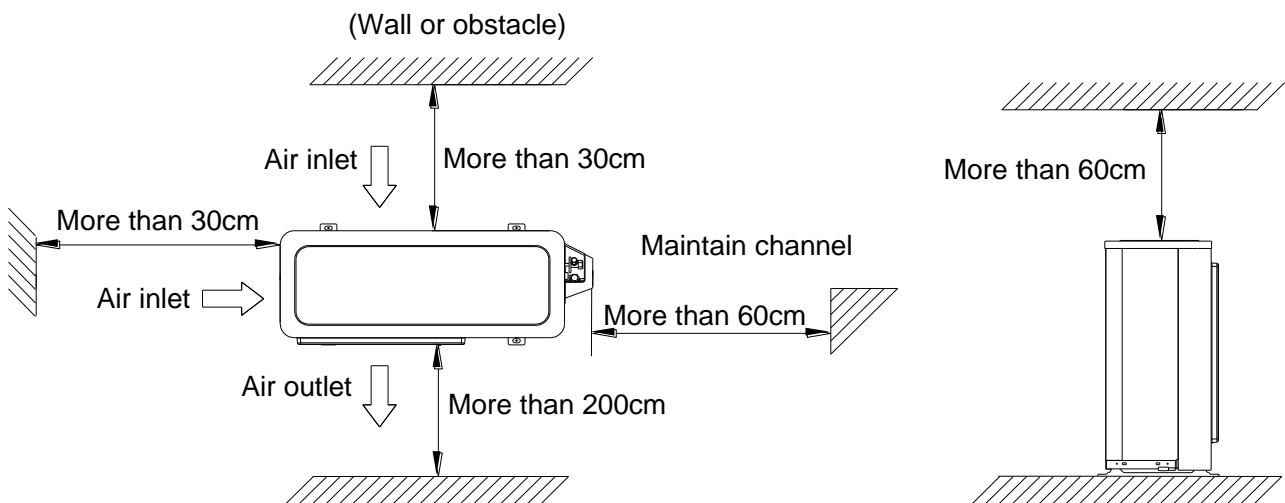

4.2 Bolt pitch

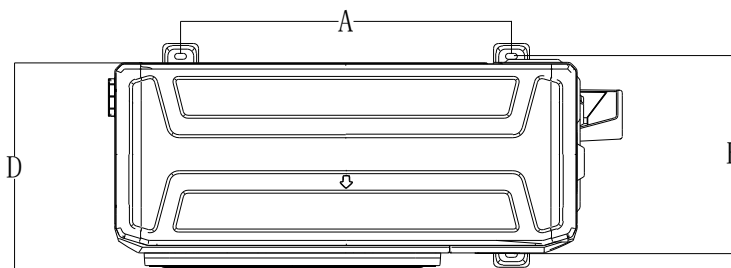

Model	A	B	D
12/16/18	514	340	333
24	540	350	363
30~42	673	403	410
48/55	634	404	415

4.3 Install the Unit

Since the gravity center of the unit is not at its physical center, so please be careful when lifting it with a sling. Never hold the inlet of the outdoor unit to prevent it from deforming.

Do not touch the fan with hands or other objects.

Do not lean it more than 45°, and do not lay it sidelong.

Make concrete foundation according to the specifications of the outdoor units.

Fasten the feet of this unit with bolts firmly to prevent it from collapsing in case of earthquake or strong wind.

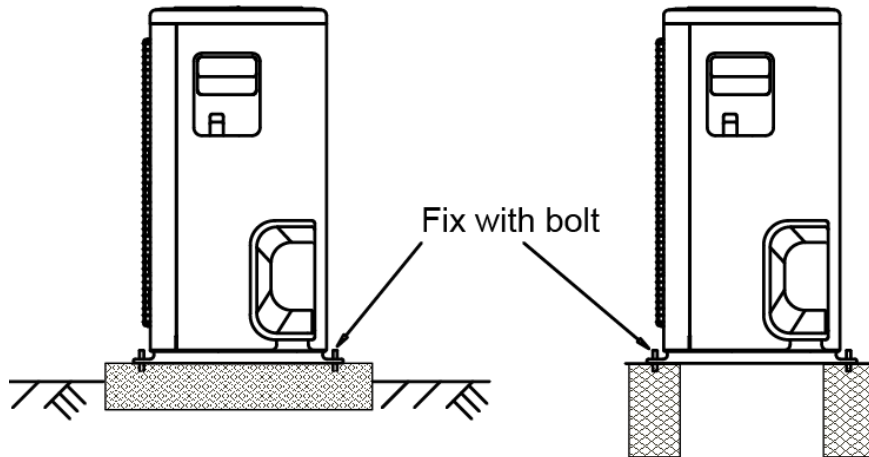

5. Refrigerant pipe installation

5.1 Maximum pipe length and height drop

Considering the allowable pipe length and height drop to decide the installation position. Make sure the distance and height drop between indoor and outdoor unit not exceeded the data in the following table.

Model	Max. Length	Max. Elevation
12,000Btu/h	25m	10m
16,000~18,000Btu/h	30m	20m
24,000Btu/h~30,000Btu/h	50m	25m
36,000Btu/h ~60,000Btu/h	65m	30m

5.2 The procedure of connecting pipes

5.2.1 Choose the pipe size according to the specification table.

5.2.2 Confirm the cross way of the pipes.

5.2.3 Measure the necessary pipe length.

5.2.4 Cut the selected pipe with pipe cutter

- Make the section flat and smooth.

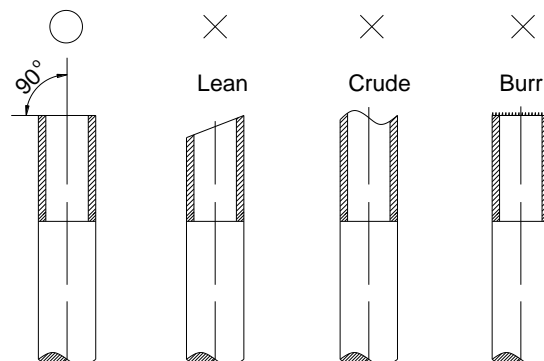

5.2.5 Insulate the copper pipe

- Before test operation, the joint parts should not be heat insulated.

5.2.6 Flare the pipe

- Insert a flare nut into the pipe before flaring the pipe
- According to the following table to flare the pipe

Pipe diameter	Flare dimension A (mm)		Flare shape
	Min	Max	
1/4" (6.35)	8.3	8.7	
3/8" (9.52)	12.0	12.4	
1/2" (12.7)	15.4	15.8	
5/8" (15.9)	18.6	19.1	
3/4" (19)	22.9	23.3	

- After flared the pipe, the opening part must be seal by end cover or adhesive tape to avoid duct or exogenous impurity come into the pipe.

5.2.7 Drill holes if the pipes need to pass the wall.

5.2.8 According to the field condition to bend the pipes so that it can pass the wall smoothly.

5.2.9 Bind and wrap the wire together with the insulated pipe if necessary.

5.2.10 Set the wall conduit

5.2.11 Set the supporter for the pipe.

5.2.12 Locate the pipe and fix it by supporter

- For horizontal refrigerant pipe, the distance between supporters should not be exceed 1m.
- For vertical refrigerant pipe, the distance between supporters should not be exceed 1.5m.

5.2.13 Connect the pipe to indoor unit and outdoor unit by using two spanners.

- Be sure to use two spanners and proper torque to fasten the nut, too large torque will damage the bellmouthing, and too small torque may cause leakage. Refer the following table for different pipe connection.

Pipe Diameter	Torque		Sketch map
	(kgf.cm)	(N.cm)	
1/4" (6.35)	144~176	1420~1720	
3/8" (9.52)	333~407	3270~3990	
1/2" (12.7)	504~616	4950~6030	
5/8" (15.9)	630~770	6180~7540	
3/4" (19)	990~1210	9270~11860	

5.3 For Units with Twins Function

5.3.1 Length and drop height permitted of the refrigerant piping

Note: Reduced length of the branching tube is the 0.5m of the equivalent length of the pipe.

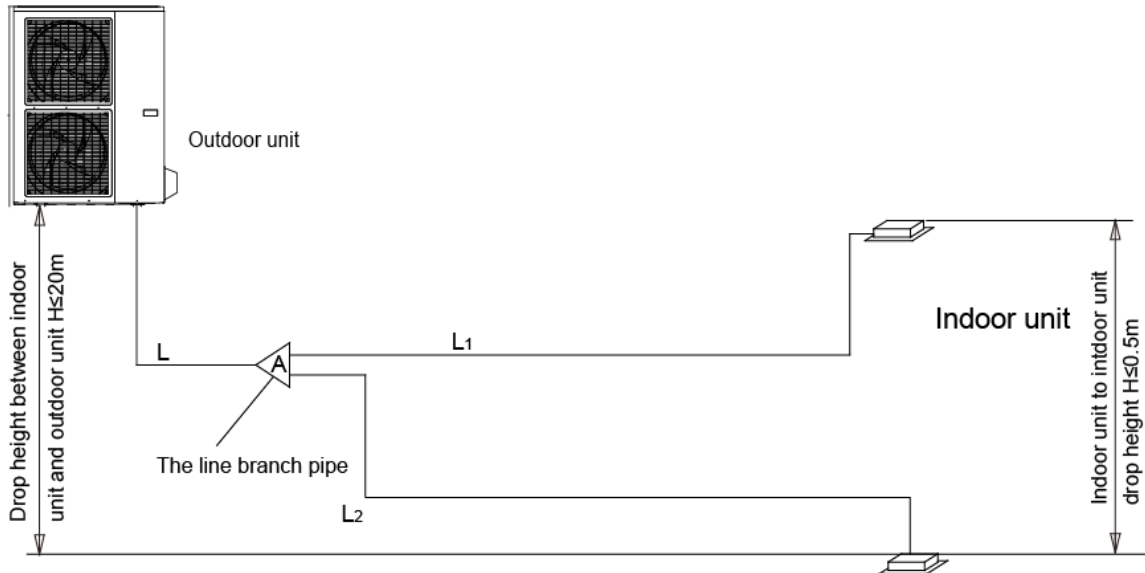

Note: All used branch pipe must be produced by Midea, otherwise it causes malfunction. The indoor units should be installed equivalently at the both side of the U type branch pipe.

		Permitted Value		Piping
Pipe Length	Total pipe length (Actual)	18K+18K	30m	L+L1+L2
		24K+24K	50m	
		30K+30K	50m	
	Max. branch pipe length		15m	L1, L2
	Max. branch pipe length difference		10m	L1-L2
Drop Height	Max. height difference between indoor unit and outdoor unit		20m	H1
	Max. height difference between indoor units		0.5m	H2

5.3.2 Size of joint pipes for indoor unit (R410a)

Capacity of indoor unit (A)	Size of main pipe(mm)		
	Gas side	Liquid side	Available branching pipe
18K	Φ12.7	Φ6.35	CE-FQZHN-01C
24K	Φ15.9	Φ9.5	CE-FQZHN-01C
30K	Φ15.9	Φ9.5	CE-FQZHN-01C

5.3.3 Size of joint pipes for outdoor unit (R410a)

Model	the size of main pipe(mm)		
	Gas side	Liquid side	The 1st branching pipe
36K	Φ15.9	Φ9.5	CE-FQZHN-01C
48K	Φ15.9	Φ9.5	CE-FQZHN-01C
60K	Φ15.9	Φ9.5	CE-FQZHN-01C

5.3.4 The branching pipe must be installed horizontally, error angle of it should not large than 10°. Otherwise, malfunction will be caused.

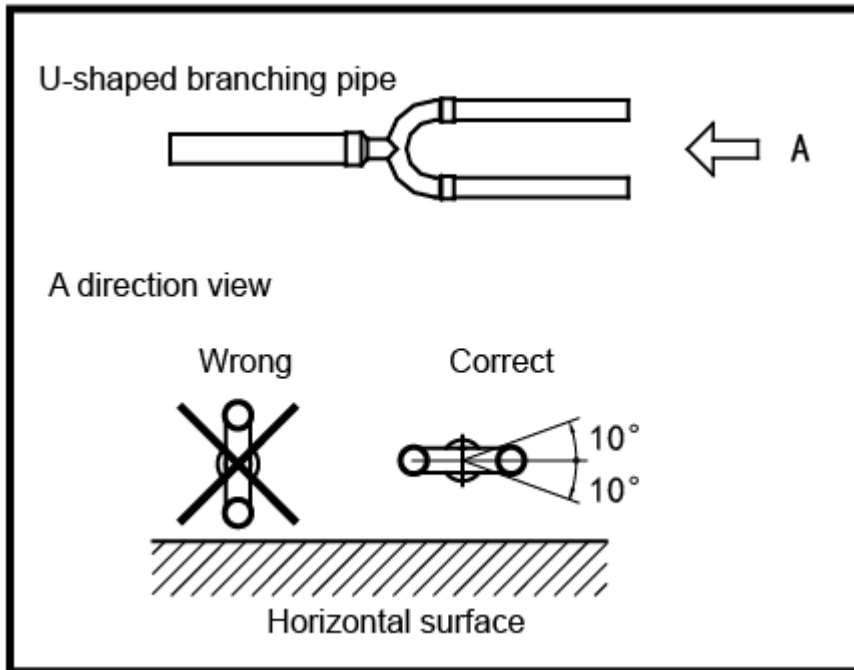

6. Drainage pipe installation

Install the drainage pipe as shown below and take measures against condensation. Improperly installation could lead to leakage and eventually wet furniture and belongings.

6.1 Installation principle

- Ensure at least 1/100 slope of the drainage pipe
- Adopt suitable pipe diameter
- Adopt nearby condensate water discharge

6.2 Key points of drainage water pipe installation

6.2.1 Considering the pipeline route and elevation

- Before installing condensate water pipeline, determine its route and elevation to avoid intersection with other pipelines and ensure slope is straight.

6.2.2 Drainage pipe selection

- The drainage pipe diameter shall not small than the drain hose of indoor unit
- According to the water flowrate and drainage pipe slope to choose the suitable pipe, the water flowrate is decided by the capacity of indoor unit.

Relationship between water flowrate and capacity of indoor unit

Capacity (x1000Btu)	Water flowrate (l/h)
12	2.4
18	4
24	6
30	7
36	8
42	10
48	12
60	14

According to the above table to calculate the total water flowrate for the confluence pipe selection.

For horizontal drainage pipe (The following table is for reference)

PVC pipe	Reference value of inner diameter of pipe (mm)	Allowable maximum water flowrate (l/h)		Remark
		Slope 1/50	Slope 1/100	
PVC25	20	39	27	For branch pipe
PVC32	25	70	50	
PVC40	31	125	88	Could be used for confluence pipe
PVC50	40	247	175	
PVC63	51	473	334	

Attention: Adopt PVC40 or bigger pipe to be the main pipe.

For Vertical drainage pipe (The following table is for reference)

PVC pipe	Reference value of inner diameter of pipe (mm)	Allowable maximum water flowrate (l/h)	Remark
PVC25	20	220	For branch pipe
PVC32	25	410	
PVC40	31	730	Could be used for confluence pipe
PVC50	40	1440	
PVC63	51	2760	
PVC75	67	5710	
PVC90	77	8280	

Attention: Adopt PVC40 or bigger pipe to be the main pipe.

6.2.3 Individual design of drainage pipe system

- The drainage pipe of air conditioner shall be installed separately with other sewage pipe, rainwater pipe and drainage pipe in building.
- The drainage pipe of the indoor unit with water pump should be apart from the one without water pump.

6.2.4 Supporter gap of drainage pipe

- In general, the supporter gap of the drainage pipe horizontal pipe and vertical pipe is respectively 1m~1.5m and 1.5m~2.0m.
- Each vertical pipe shall be equipped with not less than two hangers.
- Overlarge hanger gap for horizontal pipe shall create bending, thus leading to air block.

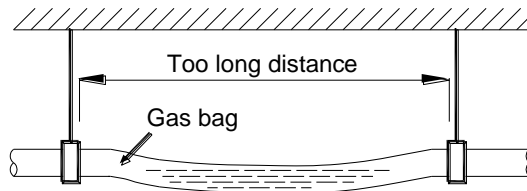

6.2.5 The horizontal pipe layout should avoid converse flow or bad flow

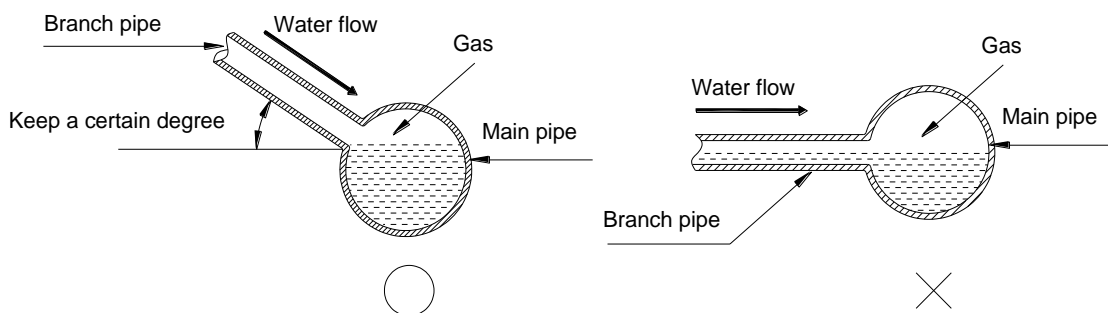
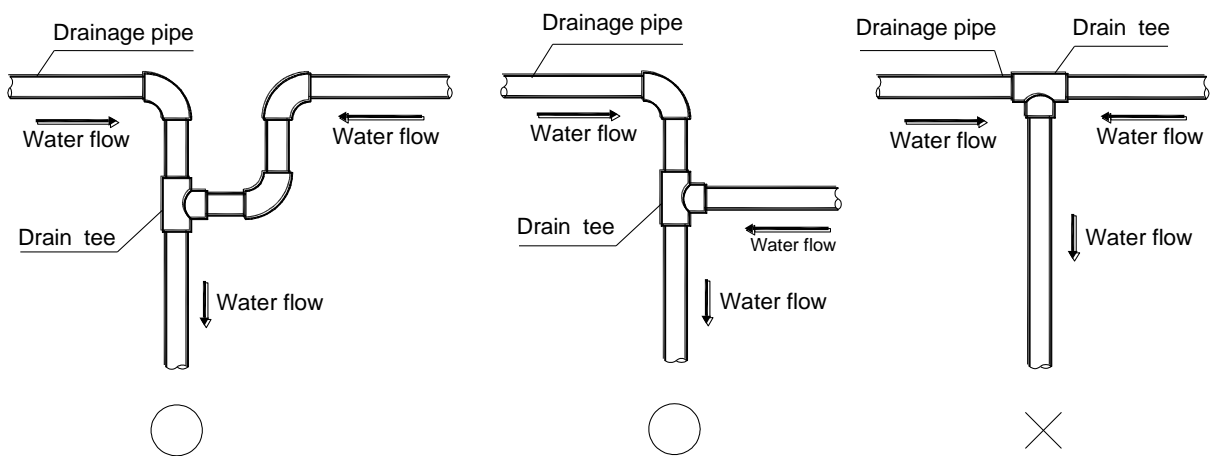

- The correct installation will not cause converse water flow and the slope of the branch pipes can be adjusted freely
- The false installation will cause converse water flow and the slope of the branch pipe can not be adjusted.

6.2.6 Water storage pipe setting

- If the indoor unit has high extra static pressure and without water pump to elevate the condensate water, such as high extra static pressure duct unit, the water storage pipe should be set to avoid converse flow or blow water phenomena.

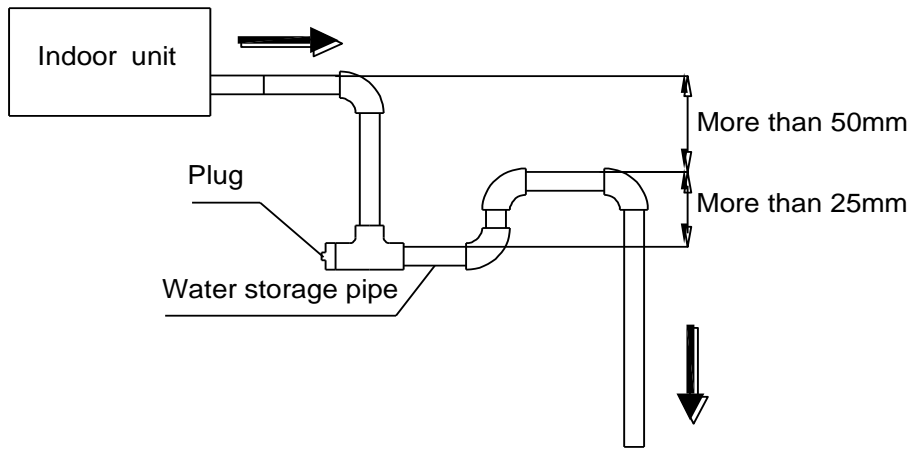

6.2.7 Lifting pipe setting of indoor unit with water pump

- The length of lifting pipe should not exceed the pump head of indoor unit water pump.
 Pump head of big four way cassette: 750mm
 Pump head of compact four way cassette: 500mm
- The drainage pipe should be set down inclined after the lifting pipe immediately to avoid wrong operation of water level switch.
- Refer the following picture for installation reference.

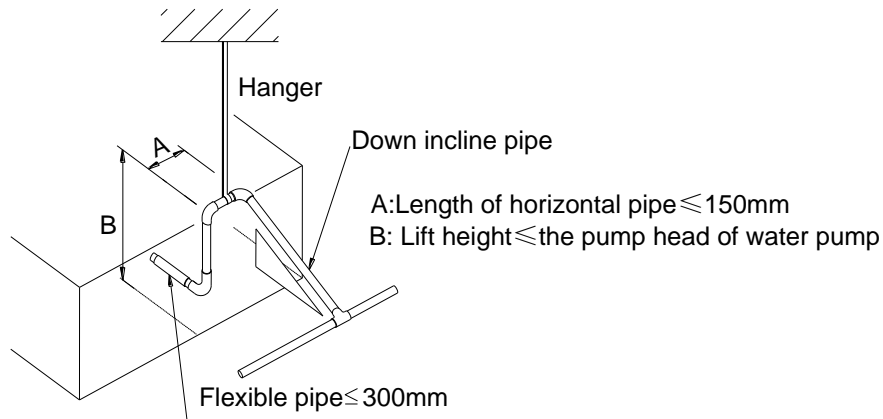

6.2.8 Blowhole setting

- For the concentrated drainage pipe system, there should design a blowhole at the highest point of main pipe to ensure the condensate water discharge smoothly.
- The air outlet shall face down to prevent dirt entering pipe.
- Each indoor unit of the system should be installed it.
- The installation should be considering the convenience for future cleaning.

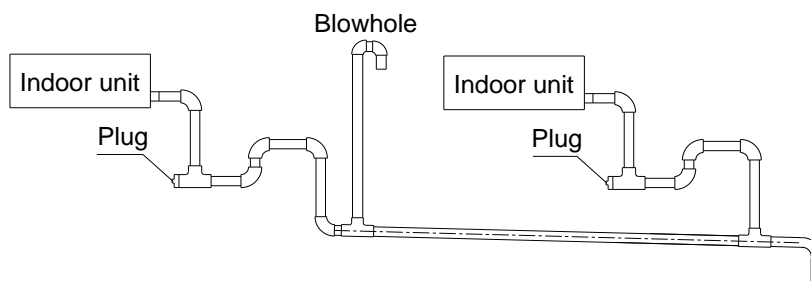

6.2.9 The end of drainage pipe shall not contact with ground directly.

6.3 Drainage test

6.3.1 Water leakage test

After finishing the construction of drainage pipe system, fill the pipe with water and keep it for 24 hours to check whether there is leakage at joint section.

6.3.2 Water discharge test

1. Natural drainage mode(the indoor unit with outdoor drainage pump)

Infuse above 600ml water through water test hole slowly into the water collector, observe whether the water can discharge through the transparent hard pipe at drainage outlet.
2. Pump drainage mode
 - 2.1 Disconnect the plug of water level switch, remove the cover of water test hole and slowly infuse about 2000ml water through the water test hole, be sure that the water will not touch the motor of drainage pump.

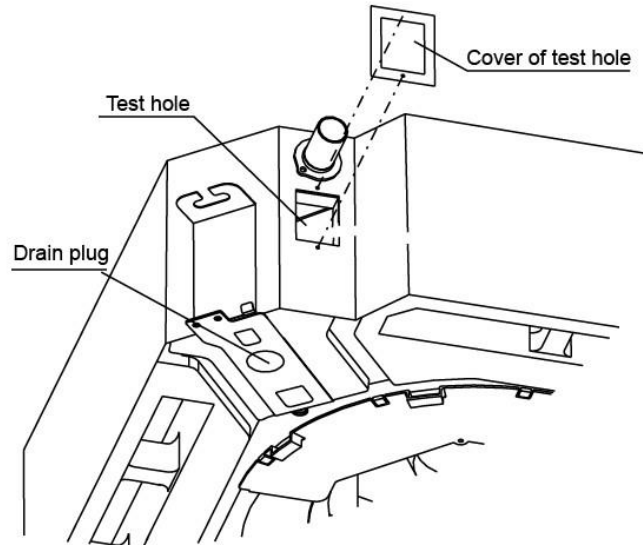

- 2.2 Power on and let the air conditioner operate for cooling. Check operation status of drainage pump, and then connect the plug of water level switch, check the operation sound of water pump and observe whether the water can discharge through the transparent hard pipe at drainage outlet. (In light of the length of drainage pipe, water shall be discharged about 1 minute delayed)
- 2.3 Stop the operation of air conditioner, power off the power supply and put the cover of water test hole back to the original place.
 - a. After stopped the air conditioner 3 minutes, check whether there is anything abnormal. If drainage pipes have not been distributed properly, over back-flow water shall cause the flashing of alarm indicator at remote-controlled receiving board and even water shall run over the water collector.
 - b. Continuously infusing water until water level alarmed, check whether the drainage pump could discharge water at once. If water level does not decline under warning water level 3 minutes later, it shall cause shutdown of unit. When this situation happens, the normal startup only can be recovered by turning down power supply and eliminating accumulated water.

Note: Drain plug at the main water-containing plate is used for eliminating accumulated water in water-containing plate when maintaining air conditioner fault. During normal operation, the plug shall be filled in to prevent leakage.

6.4 Insulation work of drainage pipe

Refer the introduction to the insulation engineering parts.

7. Vacuum Drying and Leakage Checking

7.1 Purpose of vacuum drying

- Eliminating moisture in system to prevent the phenomena of ice-blockage and copper oxidation. Ice-blockage shall cause abnormal operation of system, while copper oxide shall damage compressor.
- Eliminating the non-condensable gas (air) in system to prevent the components oxidizing, pressure fluctuation and bad heat exchange during the operation of system.

7.2 Selection of vacuum pump

- The ultimate vacuum degree of vacuum pump shall be -756mmHg or above.
- Precision of vacuum pump shall reach 0.02mmHg or above.

7.3 Operation procedure for vacuum drying

Due to different construction environment, two kinds of vacuum drying ways could be chosen, namely ordinary vacuum drying and special vacuum drying.

7.3.1 Ordinary vacuum drying

1. When conduct first vacuum drying, connect pressure gauge to the infusing mouth of gas pipe and liquid pipe, and keep vacuum pump running for 1hour (vacuum degree of vacuum pump shall be reached -755mmHg).
2. If the vacuum degree of vacuum pump could not reach -755mmHg after 1 hour of drying, it indicates that there is moisture or leakage in pipeline system and need to go on with drying for half an hour.
3. If the vacuum degree of vacuum pump still could not reach -755mmHg after 1.5 hours of drying, check whether there is leakage source.
4. Leakage test: After the vacuum degree reaches -755mmHg, stop vacuum drying and keep the pressure for 1 hour. If the indicator of vacuum gauge does not go up, it is qualified. If going up, it indicates that there is moisture or leak source.

7.3.2 Special vacuum drying

The special vacuum drying method shall be adopted when:

1. Finding moisture during flushing refrigerant pipe.
2. Conducting construction on rainy day, because rain water might penetrated into pipeline.
3. Construction period is long, and rain water might penetrated into pipeline.
4. Rain water might penetrate into pipeline during construction.

Procedures of special vacuum drying are as follows:

1. Vacuum drying for 1 hour.
2. Vacuum damage, filling nitrogen to reach 0.5Kgf/cm² .
Because nitrogen is dry gas, vacuum damage could achieve the effect of vacuum drying, but this method could not achieve drying thoroughly when there is too much moisture. Therefore, special attention shall be drawn to prevent the entering of water and the formation of condensate water.
3. Vacuum drying again for half an hour.
If the pressure reached -755mmHg, start to pressure leakage test. If it cannot reached the value, repeat vacuum damage and vacuum drying again for 1 hour.
4. Leakage test: After the vacuum degree reaches -755mmHg, stop vacuum drying and keep the pressure for 1 hour. If the indicator of vacuum gauge does not go up, it is qualified. If going up, it indicates that there is moisture or leak source.

8. Additional refrigerant charge

- After the vacuum drying process is carried out, the additional refrigerant charge process need to be performed.
- The outdoor unit is factory charged with refrigerant. The additional refrigerant charge volume is decided by the diameter and length of the liquid pipe between indoor and outdoor unit. Refer the following formula to calculate the charge volume.

Diameter of liquid pipe (mm)	Φ6.35	Φ9.52
Formula	$V=15g/m \times (L-5)$	$V=30g/m \times (L-5)$

V: Additional refrigerant charge volume (g).

L : The length of the liquid pipe (m).

Note:

- Refrigerant may only be charged after performed the vacuum drying process.
- Always use gloves and glasses to protect your hands and eyes during the charge work.
- Use electronic scale or fluid infusion apparatus to weight refrigerant to be recharged. Be sure to avoid extra refrigerant charged, it may cause liquid hammer of the compressor or protections.
- Use supplementing flexible pipe to connect refrigerant cylinder, pressure gauge and outdoor unit. And The refrigerant should be charged in liquid state. Before recharging, The air in the flexible pipe and manifold gauge should be exhausted.
- After finished refrigerant recharge process, check whether there is refrigerant leakage at the connection joint part.(Using gas leakage detector or soap water to detect).

9. Engineering of insulation

9.1 Insulation of refrigerant pipe

9.1.1 Operational procedure of refrigerant pipe insulation

Cut the suitable pipe → insulation (except joint section) → flare the pipe → piping layout and connection → vacuum drying → insulate the joint parts

9.1.2 Purpose of refrigerant pipe insulation

- During operation, temperature of gas pipe and liquid pipe shall be over-heating or over-cooling extremely. Therefore, it is necessary to carry out insulation; otherwise it shall debase the performance of unit and burn compressor.
- Gas pipe temperature is very low during cooling. If insulation is not enough, it shall form dew and cause leakage.
- Temperature of gas pipe is very high (generally 50-100°C) during heating. Insulation work must be carried out to prevent hurt by carelessness touching.

9.1.3 Insulation material selection for refrigerant pipe

- The burning performance should over 120°C
- According to the local law to choose insulation materials
- The thickness of insulation layer shall be above 10mm. If in hot or wet environment place, the layer of insulation should be thicker accordingly.

9.1.4 Installation highlights of insulation construction

- Gas pipe and liquid pipe shall be insulated separately, if the gas pipe and liquid pipe were insulated together; it will decrease the performance of air conditioner.

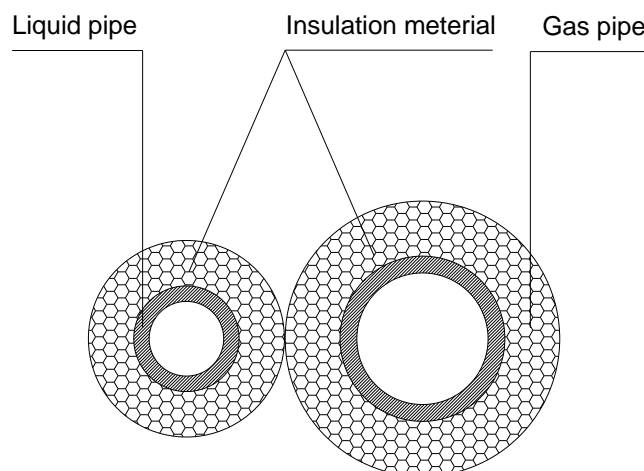

- The insulation material at the joint pipe shall be 5~10cm longer than the gap of the insulation material.
- The insulation material at the joint pipe shall be inserted into the gap of the insulation material.
- The insulation material at the joint pipe shall be banded to the gap pipe and liquid pipe tightly.
- The linking part should be use glue to paste together
- Be sure not bind the insulation material over-tight, it may extrude out the air in the material to cause bad insulation and cause easy aging of the material.

9.2 Insulation of drainage pipe

9.2.1 Operational procedure of refrigerant pipe insulation

Select the suitable pipe → insulation (except joint section) → piping layout and connection → drainage test → insulate the joint parts

9.2.2 Purpose of drainage pipe insulation

The temperature of condensate drainage water is very low. If insulation is not enough, it shall form dew and cause leakage to damage the house decoration.

9.2.3 Insulation material selection for drainage pipe

- The insulation material should be flame retardant material, the flame retardancy of the material should be selected according to the local law.
- Thickness of insulation layer is usually above 10mm.
- Use specific glue to paste the seam of insulation material, and then bind with adhesive tape. The width of tape shall not be less than 5cm. Make sure it is firm and avoid dew.

9.2.4 Installation and highlights of insulation construction

- The single pipe should be insulated before connecting to another pipe, the joint part should be insulated after the drainage test.
- There should be no insulation gap between the insulation material.

10. Engineering of electrical wiring

10.1 Highlights of electrical wiring installation

- All field wiring construction should be finished by qualified electrician.
- Air conditioning equipment should be grounded according to the local electrical regulations.
- Current leakage protection switch should be installed.
- Do not connect the power wire to the terminal of signal wire.
- When power wire is parallel with signal wire, put wires to their own wire tube and remain at least 300mm gap.
- According to table in indoor part named “the specification of the power” to choose the wiring, make sure the selected wiring not small than the date showing in the table.
- Select different colors for different wire according to relevant regulations.
- Do not use metal wire tube at the place with acid or alkali corrosion, adopt plastic wire tube to replace it.
- There must be not wire connect joint in the wire tube If joint is a must, set a connection box at the place.
- The wiring with different voltage should not be in one wire tube.
- Ensure that the color of the wires of outdoor and the terminal No. are same as those of indoor unit respectively.

11. Test operation

11.1 The test operation must be carried out after the entire installation has been completed.

11.2 Please confirm the following points before the test operation.

- The indoor unit and outdoor unit are installed properly.
- Tubing and wiring are correctly completed.
- The refrigerant pipe system is leakage-checked.
- The drainage is unimpeded.
- The ground wiring is connected correctly.
- The length of the tubing and the added stow capacity of the refrigerant have been recorded.
- The power voltage fits the rated voltage of the air conditioner.
- There is no obstacle at the outlet and inlet of the outdoor and indoor units.
- The gas-side and liquid-side stop valves are both opened.
- The air conditioner is pre-heated by turning on the power.

11.3 Test operation

Set the air conditioner under the mode of "COOLING" by remote controller, and check the following points.

Indoor unit

- Whether the switch on the remote controller works well.
- Whether the buttons on the remote controller works well.
- Whether the air flow louver moves normally.
- Whether the room temperature is adjusted well.
- Whether the indicator lights normally.
- Whether the temporary buttons works well.
- Whether the drainage is normal.
- Whether there is vibration or abnormal noise during operation.

Outdoor unit

- Whether there is vibration or abnormal noise during operation.
- Whether the generated wind, noise, or condensed of by the air conditioner have influenced your neighborhood.
- Whether any of the refrigerant is leaked.

Part 5

Electrical Control System

1. Electrical Control Function	143
2. Troubleshooting	154
3. Controller	183

1. Electrical Control Function

1.1 Definition

T1: Indoor room temperature

T2: Coil temperature of indoor heat exchanger middle.

T2B: Coil temperature of indoor heat exchanger outlet.

T3: Coil temperature of condenser

T4: Outdoor ambient temperature

T5: Compressor discharge temperature

1.2 Main Protection

1.2.1 Time delay at restart for compressor.

1.2.2 Temperature protection of compressor discharge

When the compressor discharge temp. is getting higher, the running frequency will be limited as below rules:

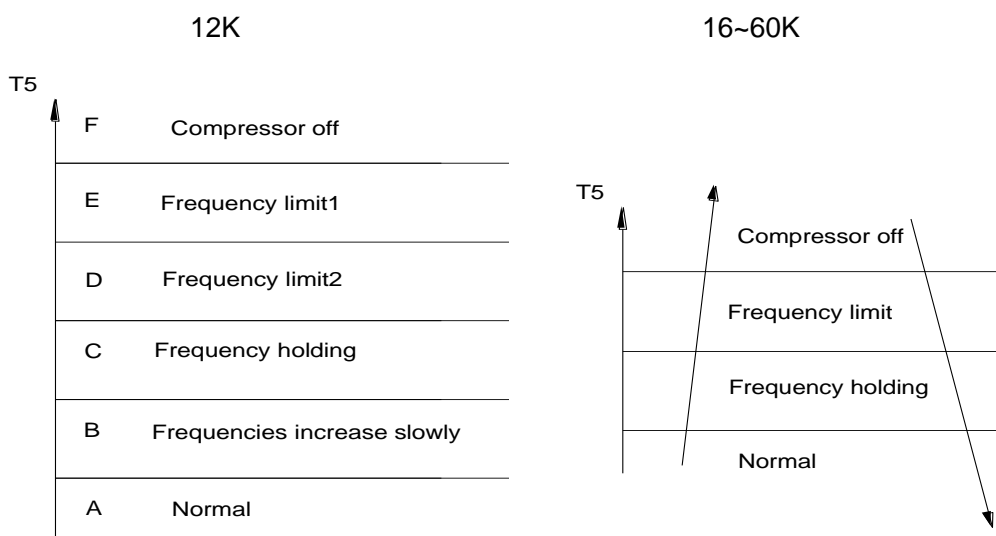

1.2.3 Sensor protection at open circuit and breaking disconnection.

1.2.5 Indoor fan delayed open function

When the unit starts up, the louver will be active immediately and the indoor fan will open 7s later.

If the unit runs in heating mode, the indoor fan will be also controlled by anti-cold wind function.

1.2.6 Fan speed is out of control

For console:

When indoor fan speed keeps too low (300RPM) for certain time, the unit will stop and the LED will display the failure.

For other models:

When indoor fan speed keeps too low (lower than 300 RPM) for 50s, the indoor fan will shut off and restart 30s later, if protection happened 3 times when fan motor restart continuously, the unit will stop and the LED will display the failure.

1.3 Operation Modes and Functions

1.3.1 Fan mode

- (1) Outdoor fan and compressor stop.
- (2) Temperature setting function is disabled, and no setting temperature is displayed.
- (3) The louver operates same as in cooling mode.
- (4) Auto fan:

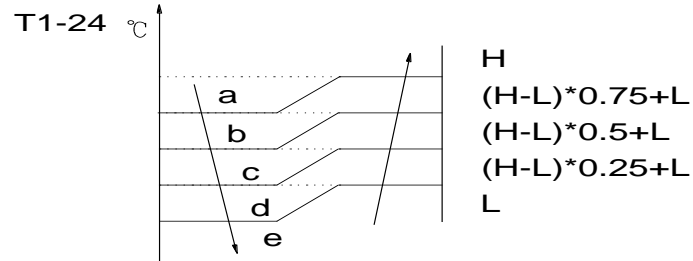

1.3.2 Cooling Mode

1.3.2.1 Outdoor fan running rules

The outdoor unit will be run at different fan speed according to T4.
 For different outdoor units, the fan speeds are different.
 12K

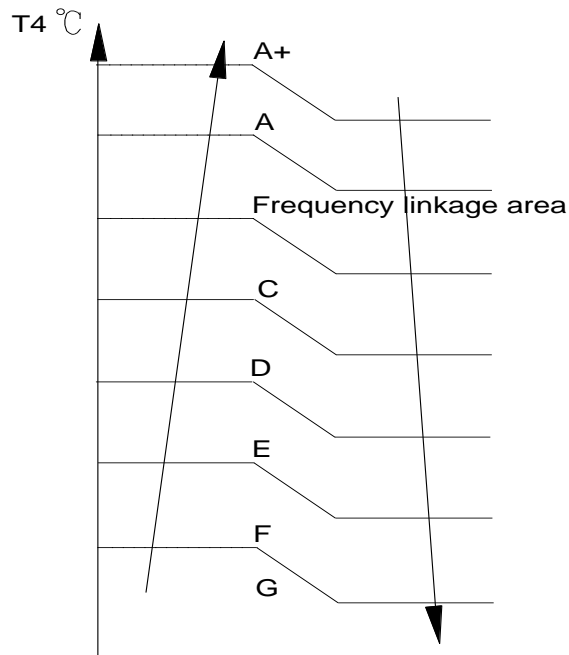

Frequency linkage area:

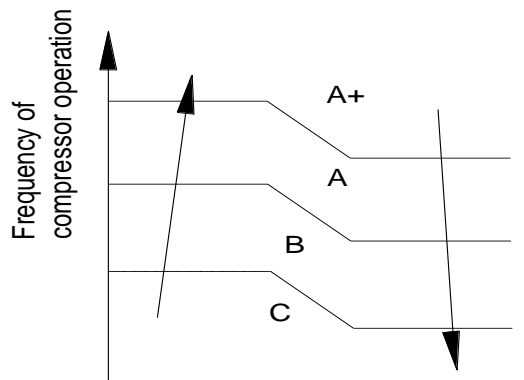

16~60K

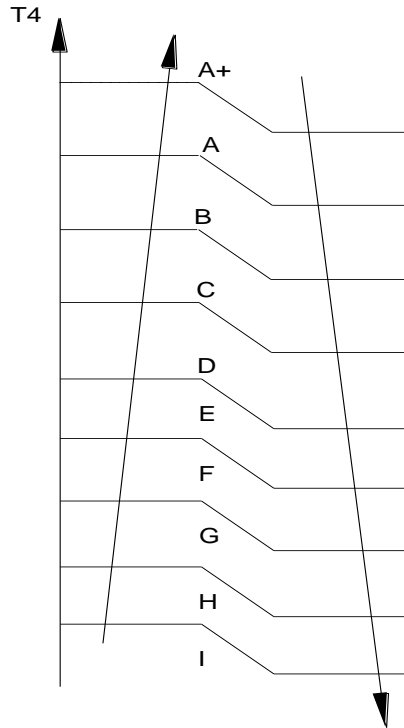

1.3.2.3 Indoor fan running rules

In cooling mode, indoor fan runs all the time and the speed can be selected as high, medium, low, auto and silent. When the compressor is running, the indoor fan is controlled as below:

Setting fan speed	T1-Td °C(°F)	Actual fan speed
H	A	H+ (H+=H+G)
	B	H (=H)
	C	H- (H-=H-G)
M	D	M+ (M+=M+Z)
	E	M (M=M)
	F	M- (M-=M-Z)
L	G	L+ (L+=L+D)
	H	L (L=L)
	I	L- (L-=L-D)

The auto fan acts as below rules:

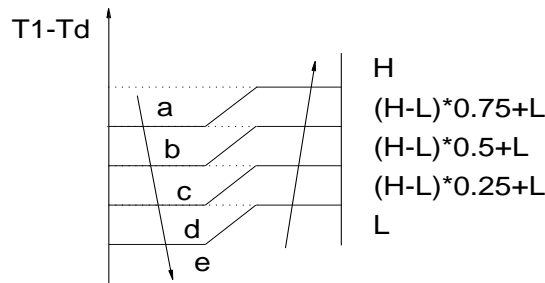

1.3.2.3 Evaporator low temperature T2 protection.

---T2<0°C, the compressor will stop and restart when T2>=5°C.

---0°C ≤ T2 < 4°C, the compressor frequency will be limited and decreased to the lower level

---4°C ≤ T2 < 7°C, the compressor will keep the current frequency.

--- $T_2 > 7^\circ\text{C}$, the compressor frequency will not be limited.

1.3.2.4 Condenser high temperature T3 protection

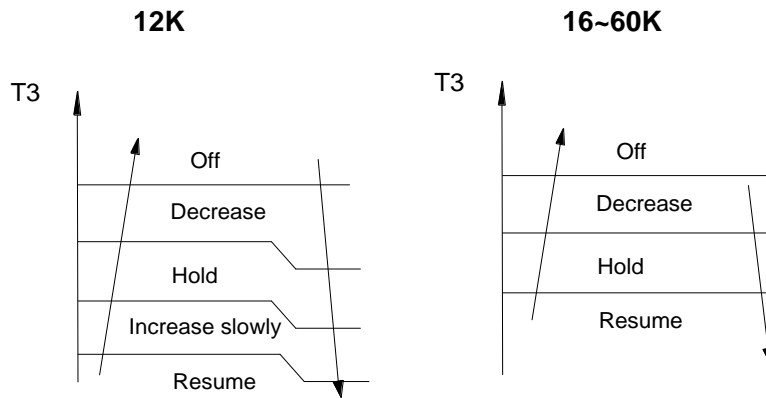

1.3.3 Heating Mode

1.3.3.1 Outdoor fan running rules:

12K

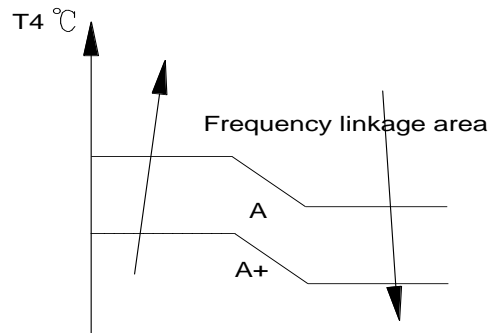

Frequency linkage area:

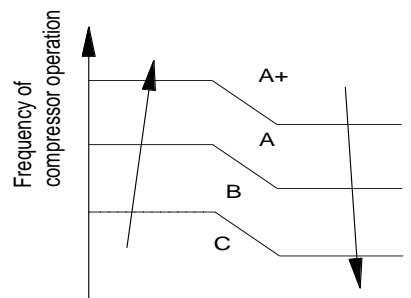

16~60K:

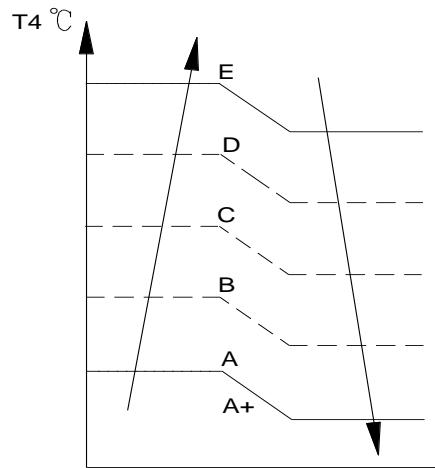

1.3.3.2 Indoor fan running rules:

In heating mode, indoor fan can be selected as high, medium, low, auto and silent. The anti-cold- wind function has the priority.

When the compressor is running, the indoor fan is controlled as below:

Setting fan speed	T1-Td°C	Actual fan speed
H		H- (H=H-G)
		H (=H)
		H+(H+=H+G)
M		M-(M=M-Z)
		M(M=M)
		M+(M+=M+Z)
L		L-(L=L-D)
		L(L=L)
		L+(L+=L+D)

If the compressor stops caused by the room temperature rising, the indoor fan will be forced to run 127 seconds with breeze. During this period, the anti-cold-wind is disabled.

Auto fan action in heating mode:

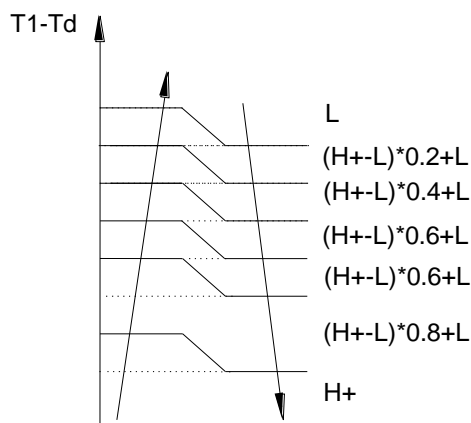

1.3.3.3 Defrosting mode :

Condition of defrosting:

AC will enter the defrosting mode according to the value of temp. of T3 and the value range of temp. change of T3 and also the compressor running time.

Condition of ending defrosting:

If any one of the following items is satisfied, the defrosting will finish and the machine will turn to normal heating mode.

---T3 rises to be higher than TCDE1°C.

---T3 keeps to be higher than TCDE2°C for 80 seconds.

---The machine has run for 10 minutes in defrosting mode.

1.3.3.4 High evaporator coil temp.T2 protection:

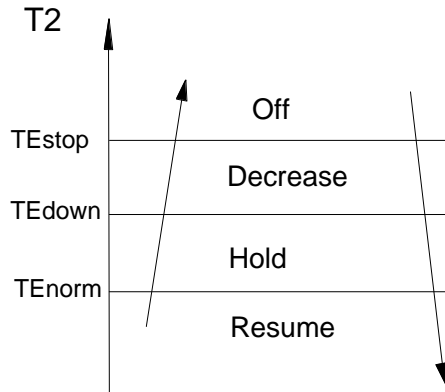

Off: Compressor stops.

Decrease: Decrease the running frequency to the lower level.

Hold: Keep the current frequency.

Resume: No limitation for frequency.

1.3.4 Auto-mode

This mode can be chosen with remote controller and the setting temperature can be changed between 17~30°C.

In auto mode, the machine will choose cooling, heating or fan-only mode according to ΔT ($\Delta T = T1 - Ts$).

$\Delta T = T1 - Ts$	Running mode
$\Delta T > 2^\circ C$	Cooling
$-2 \leq \Delta T \leq 2^\circ C$	Fan-only
$\Delta T < -2^\circ C$	Heating

Indoor fan will run at auto fan of the relevant mode.

The louver operates same as in relevant mode.

If the machine switches mode between heating and cooling, the compressor will keep stopping for 15 minutes and then choose mode according to $T1 - Ts$.

If the setting temperature is modified, the machine will choose running function again.

1.3.5 Drying mode

Indoor fan speed is fixed at breeze and can't be changed.

All protections are active and the same as that in cooling mode.

1.3.6 Timer function

1.3.6.1 Timing range is 24 hours.

1.3.6.2 Timer on. The machine will turn on automatically when reaching the setting time.

1.3.6.3 Timer off. The machine will turn off automatically when reaching the setting time.

1.3.6.4 Timer on/off. The machine will turn on automatically when reaching the setting “on” time, and then turn off automatically when reaching the setting “off” time.

1.3.6.5 Timer off/on. The machine will turn off automatically when reaching the setting “off” time, and then turn on automatically when reaching the setting “on” time.

1.3.6.6 The timer function will not change the AC current operation mode. Suppose AC is off now, it will not start up firstly after setting the “timer off” function. And when reaching the setting time, the timer LED will be off and the AC running mode has not been changed.

1.3.6.7 The setting time is relative time.

1.3.7 Economy function

1.3.7.1 The sleep function is available in cooling, heating or auto mode.

1.3.7.2. Operation process in sleep mode is as follow:

When cooling, the setting temperature rises 1°C (be lower than 30°C) every one hour, 2 hours later the setting temperature stops rising and the indoor fan is fixed at low speed.

When heating, the setting temperature decreases 1°C (be higher than 17°C) every one hour, 2 hours later the setting temperature stops rising and indoor fan is fixed at low speed. (Anti-cold wind function has the priority).

1.3.7.3 Operation time in sleep mode is 7 hours. After 7 hours the AC quits this mode but doesn't turns off, but for console, the unit will turn off.

1.3.7.4 Timer setting is available

1.3.8 Auto-Restart function

The indoor unit is equipped with auto-restart function, which is carried out through an auto-restart module. In case of a sudden power failure, the module memorizes the setting conditions before the power failure. The unit will resume the previous operation setting (not including economy function and auxiliary functions) automatically after 3 minutes when power returns.

1.3.9 Drain pump control (For Cassette)

Adopt the water-level switch to control the action of drain pump.

Main action under different condition :(every 5 seconds the system will check the water level one time)

1. When the A/C operates with cooling (including auto cooling) and forced cooling mode, the pump will start running immediately and continuously, till stop cooling.

2. Once the water level increase and up to the control point, LED will alarm and the drain pump open and continue checking the water level. If the water level fall down and LED disalarmed (drain pump delay close 1 minute) and operate with the last mode. Otherwise the entire system stop operating (including the pump) and LED remain alarming after 3 minutes.

1.3.10 Follow me(Optional)

- 1) If the indoor PCB receives the signal which results from pressing the FOLLOW ME button on remote controller, the buzzer will emit a sound and this indicates the follow me function is initiated. But when the indoor PCB receives signal which sent from remote controller every 3 minutes, the buzzer will not respond. When the unit is running with follow-me function, the PCB will control the unit according to the temperature from follow-me signal, and the temperature collection function of room temperature sensor will be shielded.
- 2) When the follow-me function is available, the PCB will not respond according to the setting temperature from follow-me signal every 3 minutes.
- 3) The PCB will take action to the mode change information from remote controller signal, and the follow-me function will be turned off. (if the wired remote controller does not initiate follow me function).
- 4) When the unit is running with follow-me function, if the PCB doesn't receive any signal from remote controller for 7 minutes or pressing FOLLOW ME button again, the follow-me function will be turned off automatically, and the temperature collection function of room temperature sensor will be available, the PCB will control the unit according to the room temperature detected from its own room temperature sensor and setting temperature.
- 5) When the indoor PCB receives the follow-me signal from wired remote controller, the control is the same as that from wireless remote controller, but buzzer will not respond. When the PCB receives turning-off follow-me signal from wired remote controller, the unit will quit follow-me function at once. The follow-me function controlled by wired remote controller prevails that by wireless remote controller.

1.3.11 Point Check Function(Excluding 12K&16K)

There is a check switch in outdoor PCB.

Press the switch SW1 to check the states of unit when the unit is running.

Press the switch N times it will display the content corresponding to No. N. After getting into the check function, it will display No. N with 1.5s, meanwhile the low bit decimal of digit display flashing, indicated to get into the check function display. After 1.5s, it will display the content corresponding to No. N.

the digital display tube will display the follow procedure when push SW1 each time.

N	Display	Remark
00	Normal display	Display running frequency, running state or malfunction code
01	Indoor unit capacity demand code	Actual data*HP*10 If capacity demand code is higher than 99, the digital display tube will show single digit and tens digit. (For example, the digital display tube show "5.0",it means the capacity demand is 15. the digital display tube show "60",it means the capacity demand is 6.0)
02	Amendatory capacity demand code	
03	The frequency after the capacity requirement transfer	

04	The frequency after the frequency limit			
05	The frequency of sending to 341			
06	Indoor unit evaporator outlet temp.(heating T2 , cooling T2B)	If the temp. is lower than -9 degree, the digital display tube will show “-9”.If the temp. is higher than 70 degree, the digital display tube will show “70”. If the indoor unit is not connected, the digital display tube will show: “——”		
07	Condenser pipe temp.(T3)			
08	Outdoor ambient temp.(T4)			
09	Compressor discharge temp.(T5)	The display value is between 0~129 degree.If the temp. is higher than 99 degree, the digital display tube will show single digit and tens digit. (For example, the digital display tube show “0.5”,it means the compressor discharge temp. is 105 degree. the digital display tube show “1.6”,it means the compressor discharge temp. is 116 degree)		
10	AD value of current	The display value is hex number.		
11	AD value of voltage			
12	Indoor unit running mode code	Off:0, Fan only 1,Cooling:2, Heating:3, Forced cooling:4, Dry:6,Self-clean:8, Forced defrosting:10		
13	Outdoor unit running mode code	Off:0, Fan only 1,Cooling:2, Heating:3, Forced cooling:4, Dry:6,Self-clean:8, Forced defrosting:10		
14	EXV open angle	Actual data/4. If the value is higher than 99, the digital display tube will show single digit and tens digit. For example ,the digital display tube show “2.0”,it means the EXV open angle is 120x4=480p.)		
15	Frequency limit symbol	Bit7	Frequency limit caused by IGBT radiator	The display value is hex number. For example, the digital display tube show 2A,then Bit5=1, Bit3=1, Bit1=1. It means frequency limit caused by T4,T3 and current.
		Bit6	Frequency limit caused by PFC	
		Bit5	Frequency limit caused by T4.	
		Bit4	Frequency limit caused by T2.	
		Bit3	Frequency limit caused by T3.	
		Bit2	Frequency limit caused by T5.	
		Bit1	Frequency limit caused by current	
Bit0	Frequency limit caused by voltage			
16	DC fan motor speed	0 : Off 1 Turbo 2 High 3 Medium 4.Low 5 Breeze 6 Supper breeze		
17	IGBT radiator temp.	The display value is between 0~130 degree..If the temp. is higher than 99 degree, the digital display tube will show single digit and tens digit. (For example, the digital display tube show “0.5”,it means the IGBT radiator temp. is 105 degree. the digital display tube show “1.6”,it means the IGBT radiator temp. is 116 degree)		
18	Indoor unit number	The indoor unit can communicate with outdoor unit well. General:1, Twins:2		
19	Condenser pipe temp. of 1# indoor unit	If the temp. is lower than 0 degree, the digital display tube will show “0”.If the temp. is higher than 70 degree, the digital display tube will show “70”. If the capacity demand is 0, , the digital display tube will show “0. If the indoor unit is not connected, the digital display tube will show: “——”(heating T2 , cooling T2B)		
20	Condenser pipe temp. of 2# indoor unit			
21	Reserved			
22	1# Indoor unit capacity demand code	Actual data*HP*10		
23	2# Indoor unit capacity demand code	If capacity demand code is higher than 99, the digital display tube will show single digit and tens digit. (For example, the digital display tube show “5.0”,it means the capacity demand is 15. the digital display tube show “60”,it means the capacity		
24	Reserved			

		demand is 6.0). If the indoor unit is not connected, the digital display tube will show: “—”
25	Indoor room temp. of 1# indoor unit	If the temp. is lower than -9 degree, the digital display tube will show “9”. If the temp. is higher than 70 degree, the digital display tube will show “70”. If the capacity demand is 0, , the digital display tube will show “0. If the indoor unit is not connected, the digital display tube will show: “—”
26	Indoor room temp. of 2# indoor unit	If the temp. is lower than 0 degree, the digital display tube will show “0”. If the temp. is higher than 70 degree, the digital display tube will show “70”. If the capacity demand is 0, , the digital display tube will show “0. If the indoor unit is not connected, the digital display tube will show: “—”
27	Average of Indoor room temp.	If the temp. is lower than 0 degree, the digital display tube will show “0”. If the temp. is higher than 70 degree, the digital display tube will show “70”.
28	Shutdown reason	Refer to Appendix
29	T2B of 1# indoor unit	If the temp. is lower than -9 degree, the digital display tube will show “9”. If the temp. is higher than 70 degree, the digital display tube will show “70”. If the capacity demand is 0, , the digital display tube will show “0. If the indoor unit is not connected, the digital display tube will show: “—”
30	T2B of 2# indoor unit	If the temp. is lower than 0 degree, the digital display tube will show “0”. If the temp. is higher than 70 degree, the digital display tube will show “70”. If the capacity demand is 0, , the digital display tube will show “0. If the indoor unit is not connected, the digital display tube will show: “—”

Appendix

Shutdown Reason	Code
Frequency limit caused by current	1
Frequency limit caused by T2.in cooling	2
Frequency limit caused by T2.in heating	3
Reach to the setting temperature	4
Frequency limit caused by T4.	5
Defrosting	6
Mode switching	7
High discharge temperature protection	9
High evaporator coil temp.T2 protection	10
Evaporator low temperature T2 protection	11
Condenser high temperature T3 protection	12
Low indoor room temperature protection in drying mode	13
Too low ambient temperature protection	14
Refrigerant leakage detection	15
Communication malfunction between indoor and outdoor units	16
Communication error between outdoor main chip and compressor driven chip IR341	17
AC power input voltage protection	18
Top temperature protection of compressor	19
Outdoor EE Malfunction	20
Fan speed has been out of control	21
Open or short circuit of temperature sensor	22
Overcurrent protection	23
IMP overcurrent protection	24
Compressor lack of phase	25
Compressor has been out of control	26
Low pressure protection of 311	27
Fan current protection	28
Fan lack of phase	29
Fan zero speed protection	30
PFC module protection	31
High pressure protection of 311	32
Zero speed malfunction	33
PWM malfunction	34
MCE malfunction	35
Compressor overcurrent protection	36
Compressor EE malfunction	37
Compressor start-up malfunction	38
311 fan speed has been out of control	39

Low pressure protection	40
High pressure protection	41
PFC module malfunction	42
Shutdown stop	49
Electrical disconnect	50
DR stop	51

2. Troubleshooting

2.1 Display board

2.1.1 Icon explanation on indoor display board (Super slim cassette).

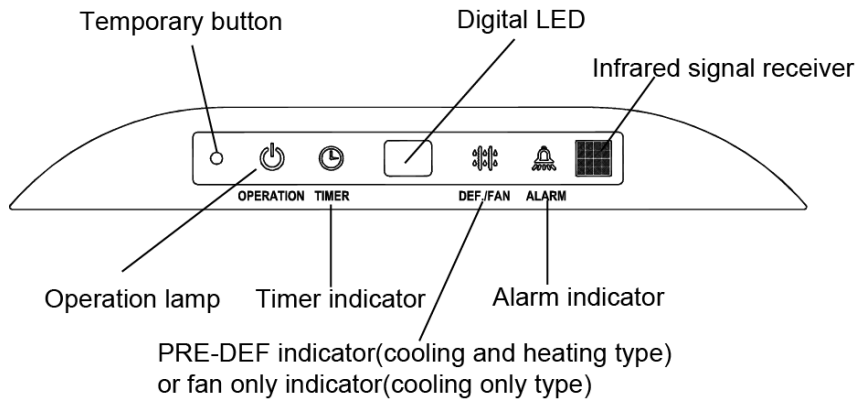

2.1.2 Icon explanation on indoor display board (A5 Duct)

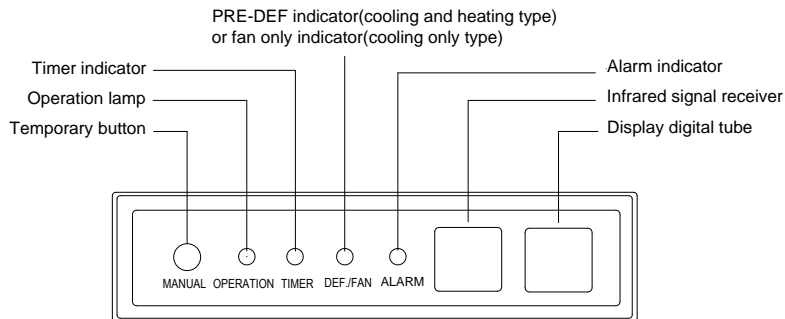

2.1.3 Auto-lifting panel of 4 way cassette

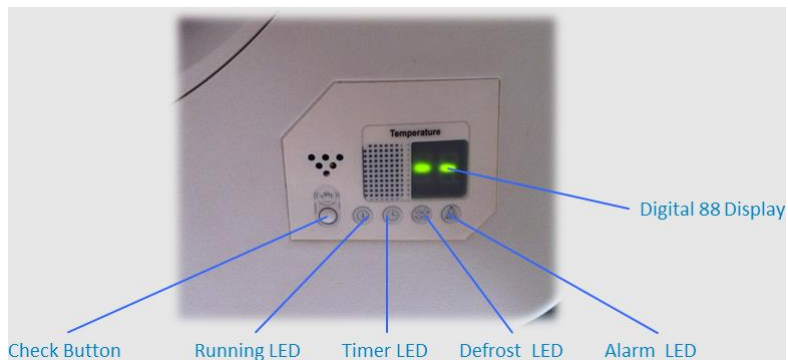

2.1.4 Display board of Ceiling-floor indoor unit

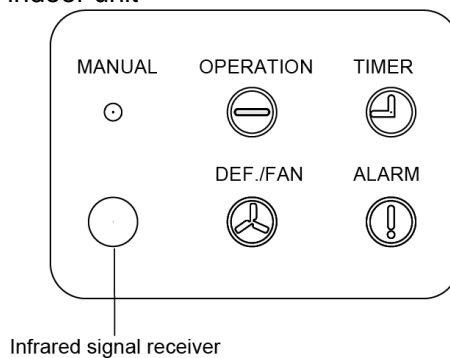

2.1.5 Icon explanation on indoor display board (Compact cassette).

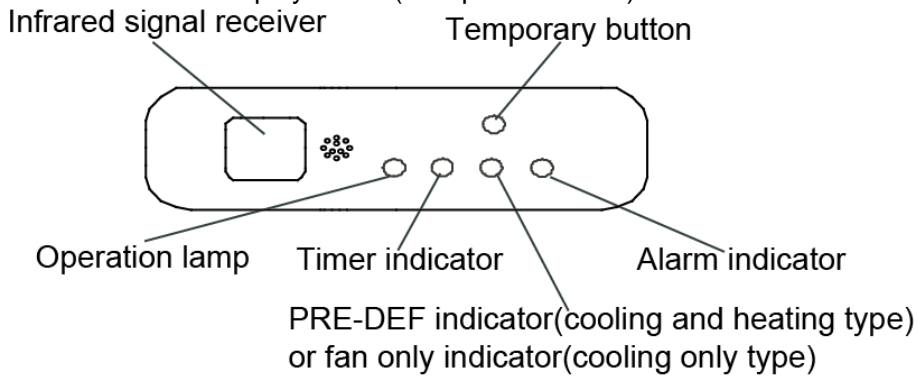

2.1.6 Icon explanation on indoor display board (Console)

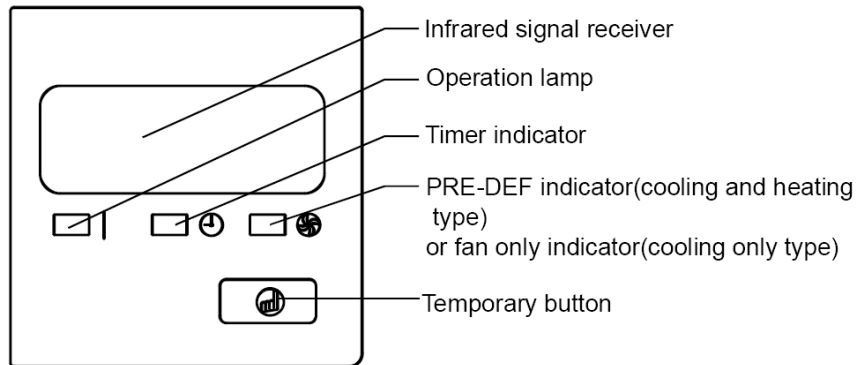

2.1.7 Display board of M floor-standing

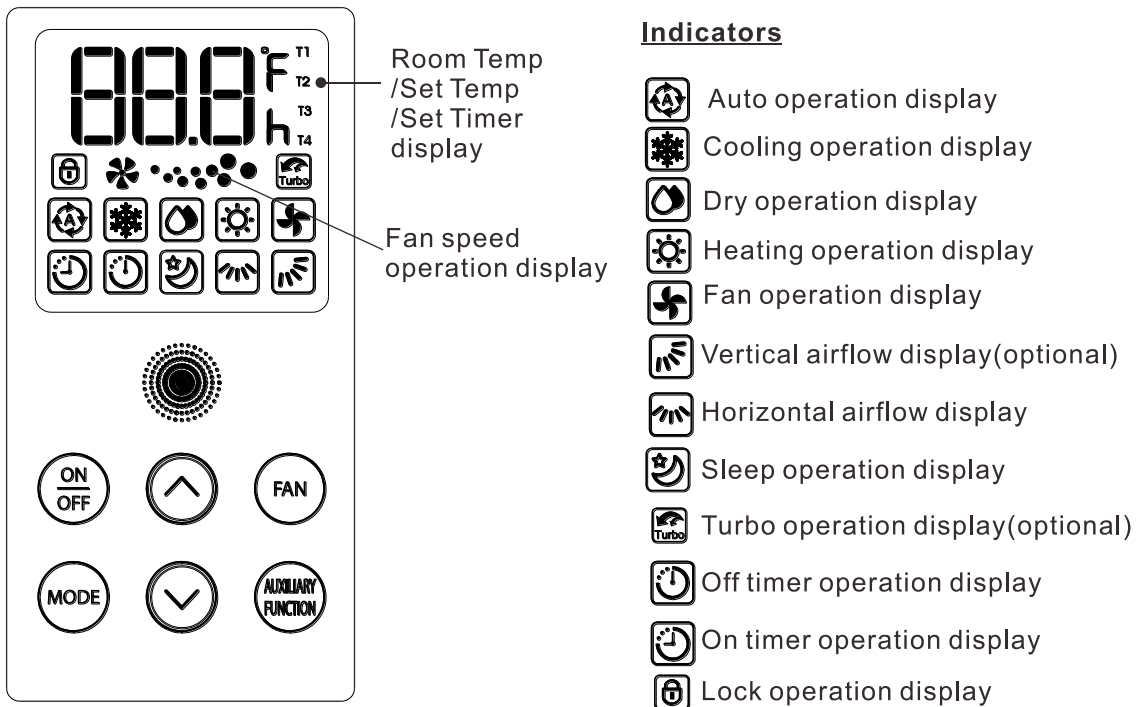

2.1.8 Display board of GA floor-standing

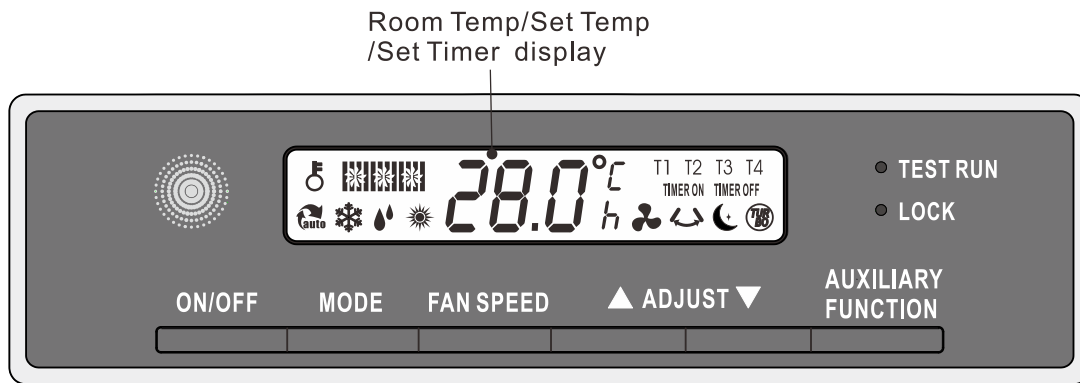

Indicators

 Auto operation display

 Cooling operation display

 Dry operation display

 Heating operation display

 Fan operation display

 Swing operation display

 Sleep operation display

 Turbo operation display

TIMER ON On timer operation display

TIMER OFF Off timer operation display

 Lock operation display

 Fan speed display

2.2 Indoor unit malfunction

For Console

Malfunction	Timer Lamp	Operation Lamp (flashes)
Indoor EEPROM malfunction	X	1
Communication malfunction between indoor and outdoor units	X	2
Indoor fan speed has been out of control	X	4
Open or short circuit of T1 temperature sensor	X	5
Open or short circuit of T2 temperature sensor	X	6
Refrigerant leakage detection	X	7
Overcurrent protection (For some units)	O	1
Open or short circuit of T4 temperature sensor	O	2
Open or short circuit of T3 temperature sensor	O	3
Open or short circuit of T5 temperature sensor	O	4
Outdoor EEPROM malfunction (For some units)	O	5
Outdoor fan speed has been out of control	O	6
IPM module malfunction	☆	1
DC voltage too high or too low protection	☆	2
Too low ambient temperature protection	☆	4
Inverter compressor drive protection	☆	5
Voltage protection of compressor	☆	7
O (on) X(off) ☆(flash at 2Hz)		

For other type (12K)

Malfunction	Error Code	Timer Lamp	Operation Lamp (flashes)
Indoor EEPROM malfunction	E0	X	1
Communication malfunction between indoor and outdoor units	E1	X	2
Indoor fan speed has been out of control	E3	X	4
Open or short circuit of T1 temperature sensor	E4	X	5
Open or short circuit of T2 temperature sensor	E5	X	6
Refrigerant leakage detection	EC	X	7
Water level alarm	EE	X	8
Communication error between master and slave unit (for twins system)	E8	X	9
Another indoor unit malfunction (for twins system)	E9	X	10
Overcurrent protection (For some units)	F0	O	1
Open or short circuit of T4 temperature sensor	F1	O	2
Open or short circuit of T3 temperature sensor	F2	O	3
Open or short circuit of T5 temperature sensor	F3	O	4
Outdoor EEPROM malfunction (For some units)	F4	O	5
Outdoor fan speed has been out of control	F5	O	6
Open or short circuit of T2B temperature sensor (For free-match indoor units)	F6	O	7
IPM module malfunction	P0	☆	1
DC voltage too high or too low protection	P1	☆	2
Too low ambient temperature protection	P3	☆	4
Inverter compressor drive protection	P4	☆	5
Voltage protection of compressor	P6	☆	7
O (on) X(off) ☆(flash at 2Hz)			

For floor standing:

Malfunction	Error Code
Indoor EEPROM malfunction	E0
Communication malfunction between indoor and outdoor units	E1
Indoor fan speed has been out of control	E3
Open or short circuit of T1 temperature sensor	E4
Open or short circuit of T2 temperature sensor	E5
Refrigerant leakage detection	EC
Outdoor unit is faulty (for old communication protocol)	Ed
Overcurrent protection (For some units)	F0
Open or short circuit of T4 temperature sensor	F1
Open or short circuit of T3 temperature sensor	F2
Open or short circuit of T5 temperature sensor	F3
Outdoor EEPROM malfunction (For some units)	F4
Outdoor fan speed has been out of control	F5
Open or short circuit of T2B temperature sensor	F6
IPM module malfunction	P0
DC voltage too high or too low protection	P1
High temperature protection of top of compressor	P2
Too low ambient temperature protection	P3
Inverter compressor drive protection	P4
Sensor of outdoor IGBT is faulty	P7

For other type (18K-60K):

Malfunction	Error Code	Timer Lamp	Operation Lamp (flashes)
Indoor EEPROM malfunction	E0	X	1
Communication malfunction between indoor and outdoor units	E1	X	2
Indoor fan speed has been out of control	E3	X	4
Open or short circuit of T1 temperature sensor	E4	X	5
Open or short circuit of T2 temperature sensor	E5	X	6
Refrigerant leakage detection	EC	X	7
Water level alarm	EE	X	8
Communication error between master and slave unit (for twins system)	E8	X	9
Another indoor unit malfunction (for twins system)	E9	X	10
Outdoor unit is faulty (for old communication protocol)	Ed	X	11
Overcurrent protection (For some units)	F0	O	1
Open or short circuit of T4 temperature sensor	F1	O	2
Open or short circuit of T3 temperature sensor	F2	O	3
Open or short circuit of T5 temperature sensor	F3	O	4
Outdoor EEPROM malfunction (For some units)	F4	O	5
Outdoor fan speed has been out of control	F5	O	6
Open or short circuit of T2B temperature sensor (For free-match indoor units)	F6	O	7
Communication error between auto-lifting panel and slim cassette (For slim cassette with auto-lifting panel)	F7	O	8
Auto-lifting panel is faulty (For slim cassette with auto-lifting panel)	F8	O	9
Auto-lifting panel is not closed (For slim cassette with auto-lifting panel)	F9	O	10
IPM module malfunction	P0	☆	1
DC voltage too high or too low protection	P1	☆	2
High temperature protection of top of compressor	P2	☆	3
Too low ambient temperature protection	P3	☆	4

Inverter compressor drive protection	P4	☆	5
Voltage protection of compressor	P6	☆	7
Sensor of outdoor IGBT is faulty	P7	☆	8
O (on) X(off) ☆(flash at 2Hz)			

2.3 Outdoor unit malfunction

For 16K:

Contents	LED1(Green)	LED2(Red)
Standby for normal	On	Off
Operation normally	Off	On
DC voltage too high or too low protection or MCE malfunction	On	On
Compressor driven chip EEPROM malfunction	On	Flash
Compressor speed has been out of control	Off	Flash
Zero speed protection or Synchronous fault protection	Flash	On
IGBT over-strong current protection or IPM module protection	Flash	Off
Communication error between outdoor main chip and compressor driven chip	Flash	Flash

For 18~60K:

Display	Malfunction or Protection
E1	Communication malfunction between indoor and outdoor units
F0	Overcurrent protection
F1	Ambient temperature sensor (T4) is malfunction
F2	Outdoor heat-exchanger temperature sensor (T3) is malfunction
F3	Discharge temperature sensor (T5) is malfunction
F4	Outdoor EEPROM is malfunction
F5	Outdoor fan speed has been out of control
P0	IPM module protection
P1	DC voltage too high or too low protection
P3	Protection of ultra-low ambient temperature
P4	Rotor position protection of compressor
J0	High temperature protection of evaporator
J1	High temperature protection of condenser
J2	High discharge temperature protection
J3	PFC module protection
J4	Communication error between outdoor main chip and compressor driven chip
J5	High pressure protection
J6	Low pressure protection
P7	IGBT sensor is malfunction
J8	AC power input voltage protection

In low ambient cooling mode, the LED displays "LC" or alternative displays between running frequency and "LC"(each displays 0.5s)

2.4 Solving steps for typical malfunction

2.4.1 For the indoor unit

2.4.1.1 Open or short circuit of temperature sensor

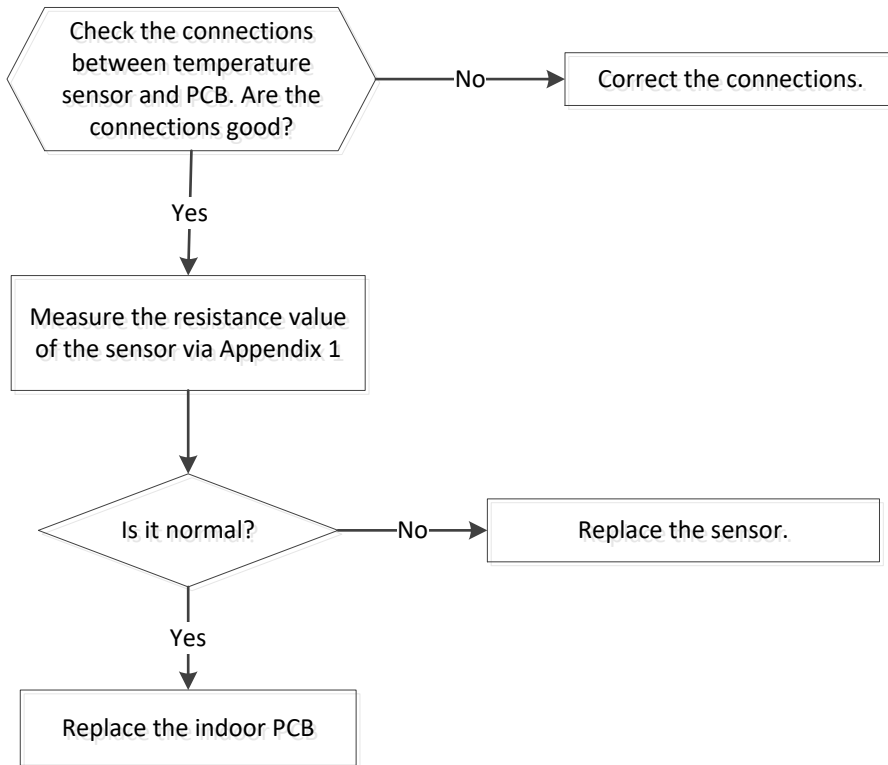

2.4.1.2. Outdoor unit malfunction

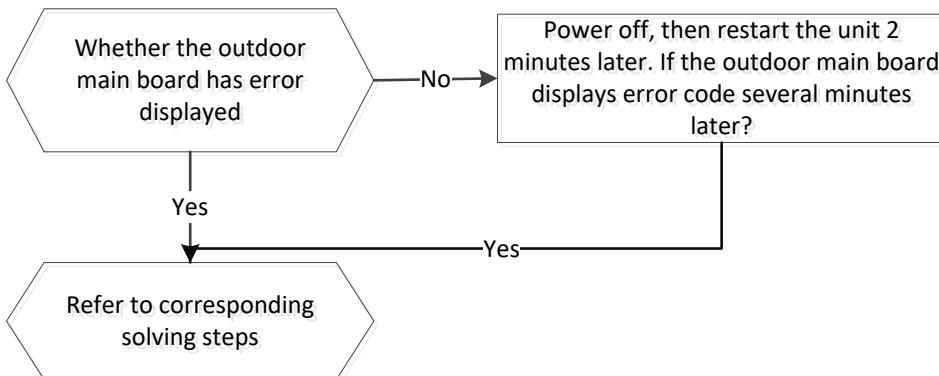

2.4.1.3. Indoor EEPROM malfunction

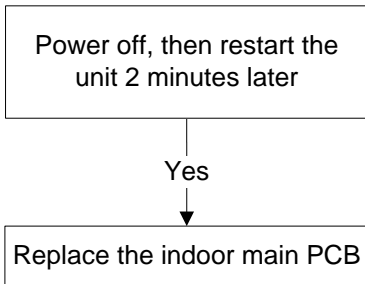

EEPROM: An electrically erasable programmable read-only memory whose contents can be erased and reprogrammed using a pulsed voltage.

2.4.1.4. Water-level alarm malfunction

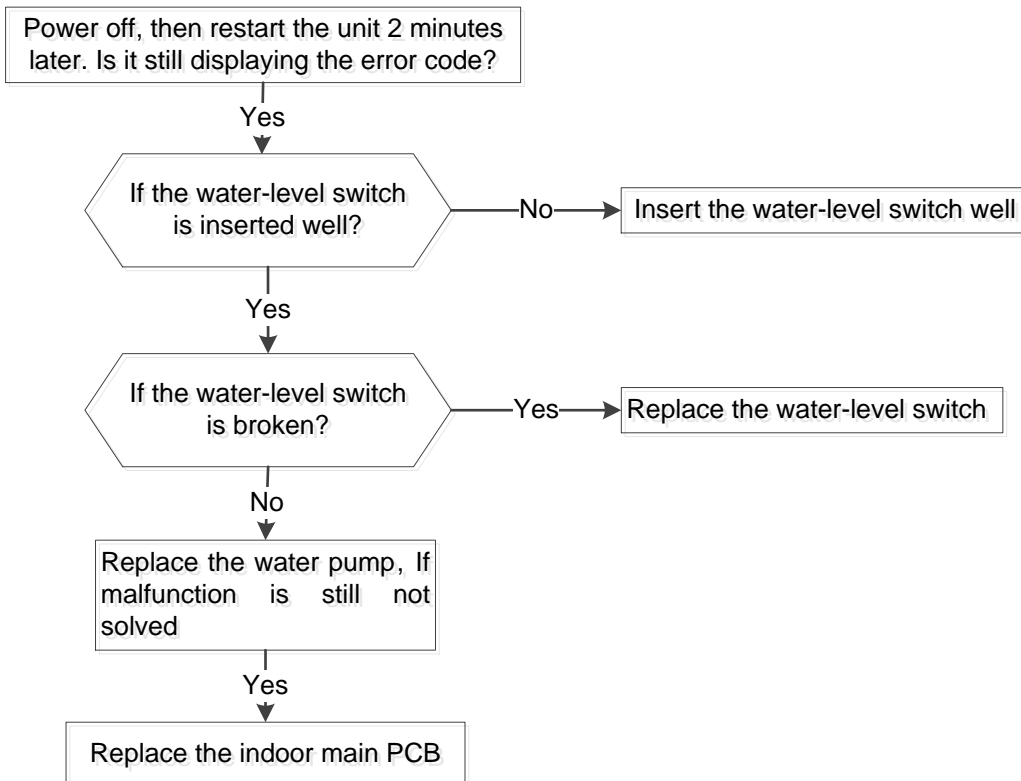

2.4.1.5. Indoor fan speed has been out of control.

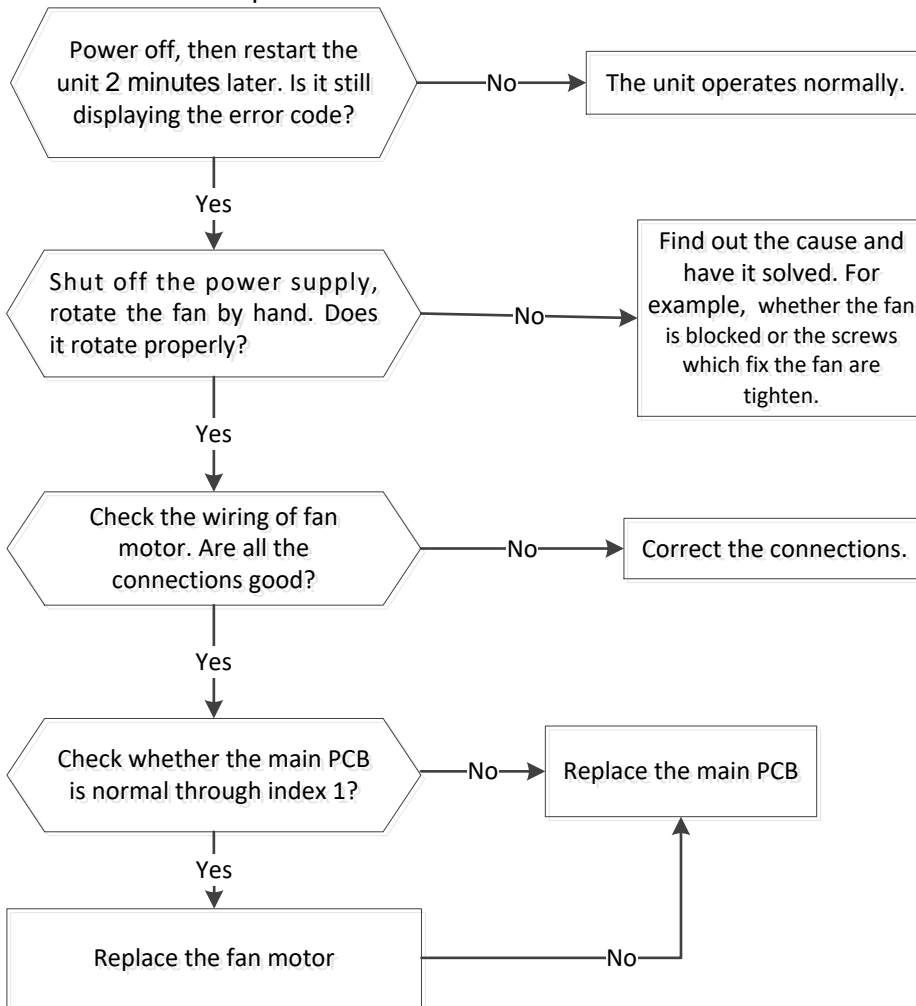

Index 1:

1. Indoor DC fan motor(control chip is inside fan motor)

Power on and when the unit is in standby, measure the voltage of pin1-pin3, pin4-pin3 in fan motor connector. If the value of the voltage is not in the range showing in below table, the PCB must have problems and need to be replaced.

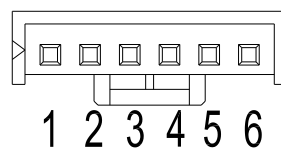
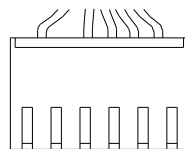

DC motor voltage input and output

NO.	Color	Signal	Voltage
1	Red	Vs/Vm	200V~380V
2	---	---	---
3	Black	GND	0V
4	White	Vcc	13.5-16.5V
5	Yellow	Vsp	0~6.5V
6	Blue	FG	13.5-16.5V

2.4.1.6. Refrigerant Leakage Detection

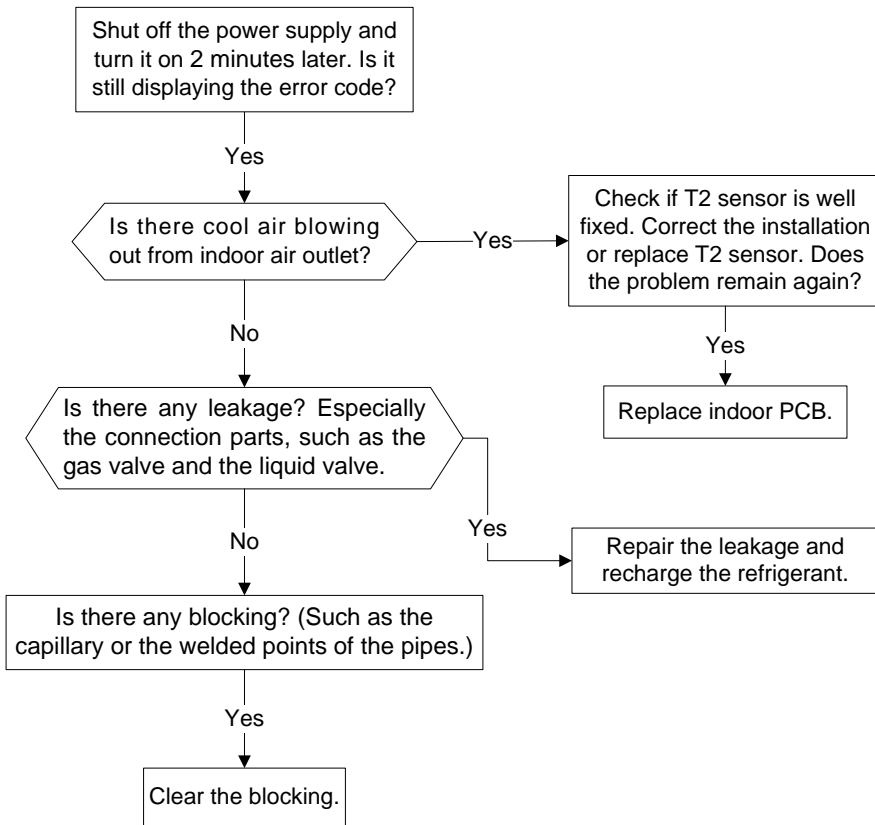

2.4.1.7 Communication malfunction between indoor and outdoor units
 The same as E1 in outdoor.

2.4.2 For the super-slim cassette with up-down panel

2.4.2.1 Communication error between indoor unit and up-down panel

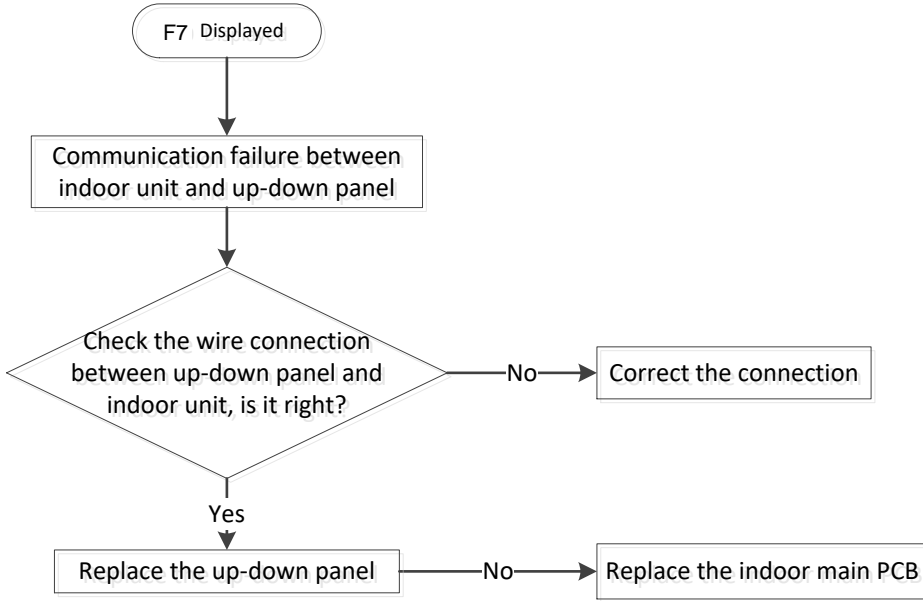

2.4.2.2 Up-down panel is defective

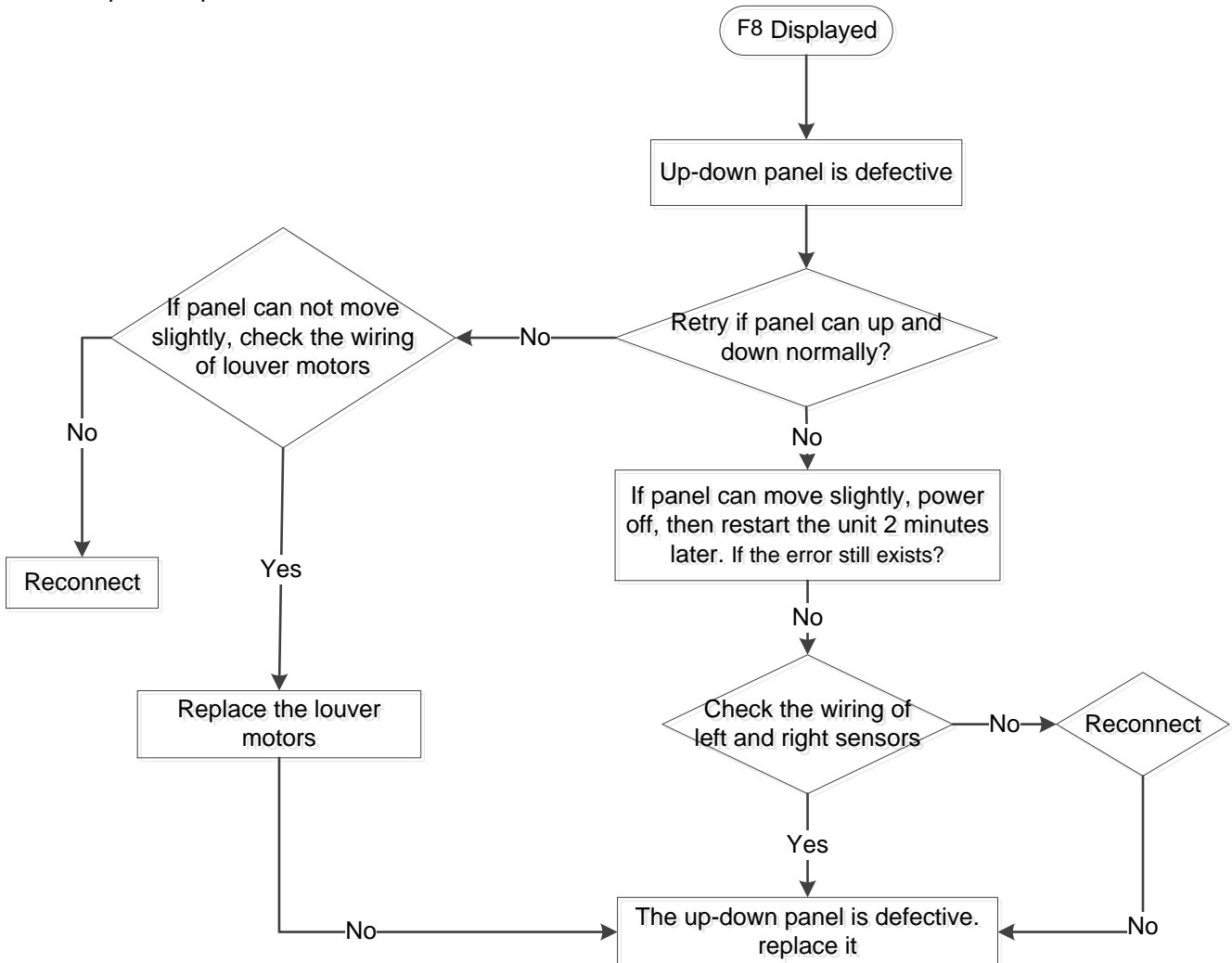

2.4.3 For the unit with TWINS function (For the super-slim cassette & A5 duct)

2.4.3.1 Communication malfunction between master unit and indoor unit

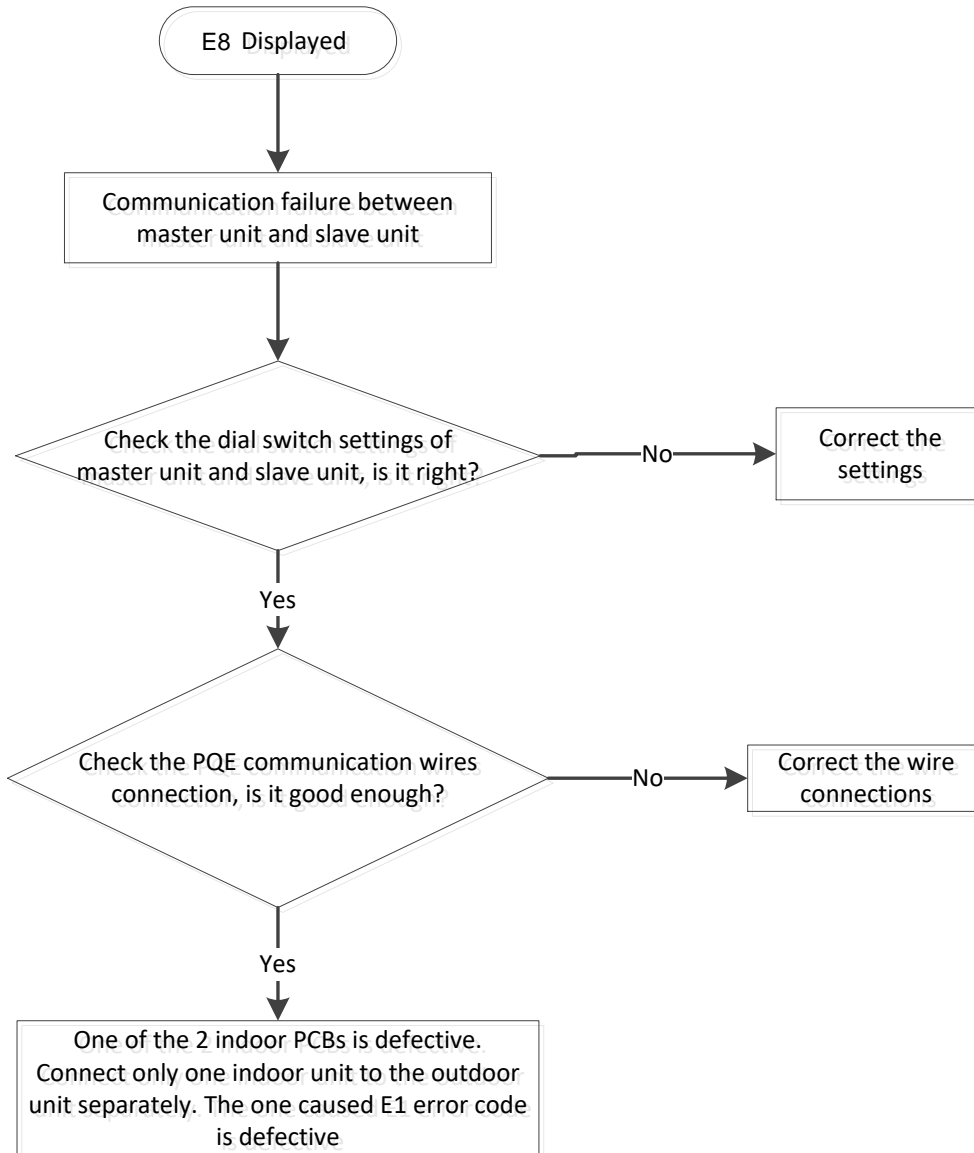

2.4.3.2 Other malfunction between master unit and indoor unit

One indoor unit displays "E9", which means another indoor unit is faulty. Check another indoor unit's error code and then follow the appropriate solutions to solve the malfunction.

2.4.4 For the outdoor unit

2.4.4.1. Compressor driven chip EEPROM malfunction

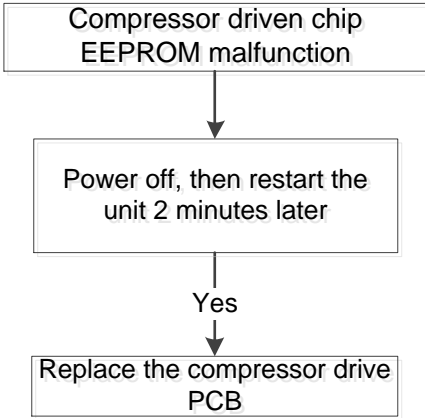

2.4.4.2 Compressor speed has been out of control/ Zero speed protection / Synchronous fault protection

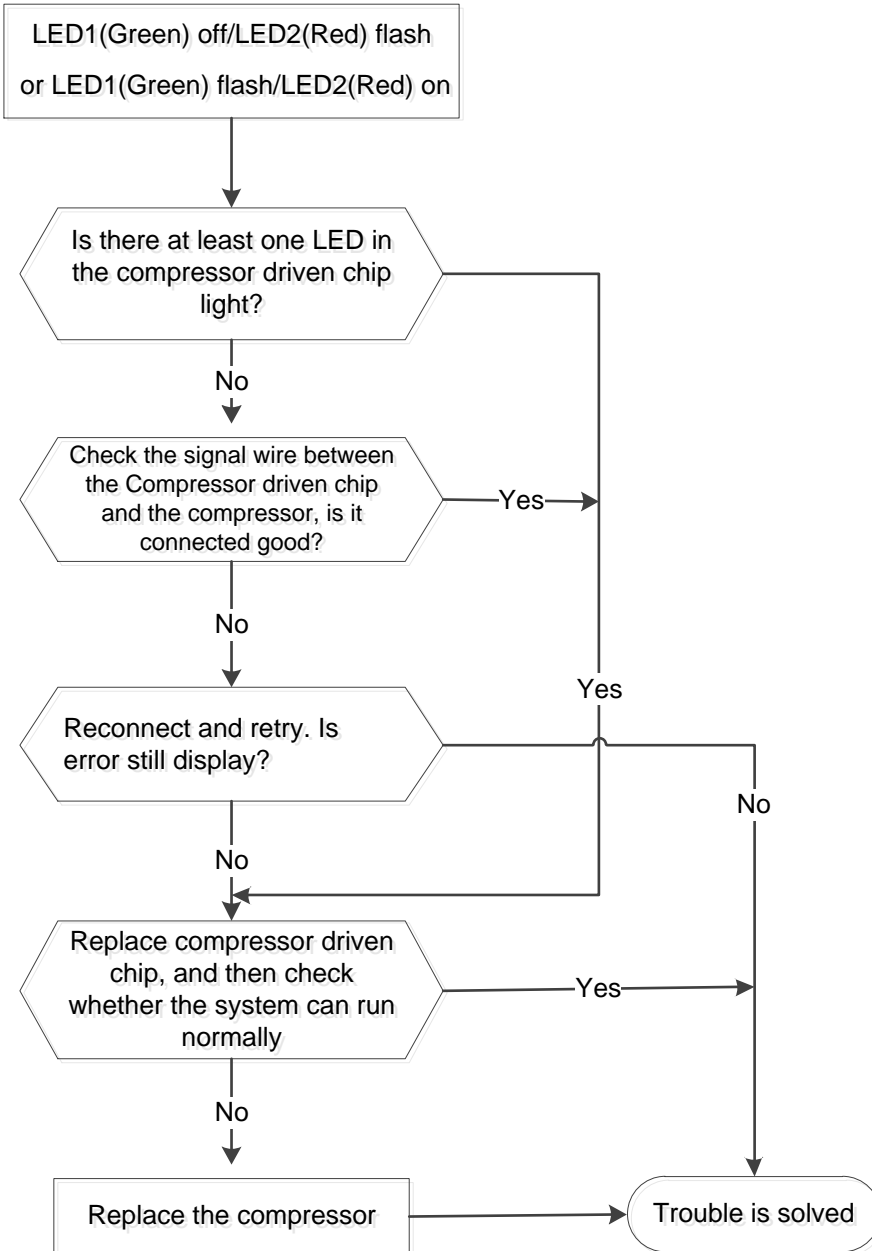

2.4.4.3 MCE malfunction

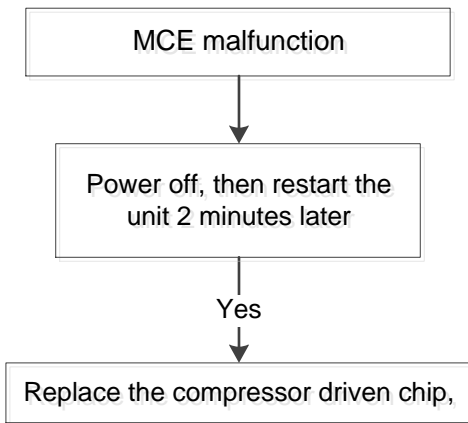

2.4.4.4. F4 malfunction

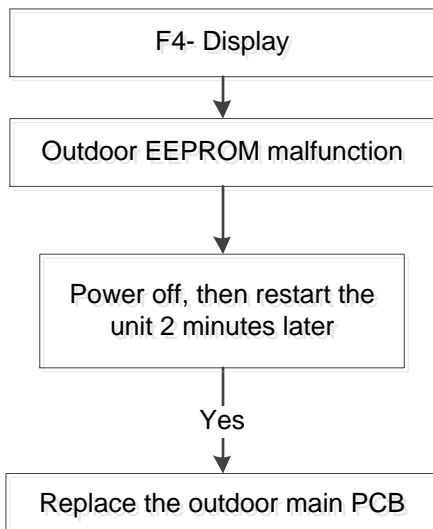

EEPROM: An electrically erasable programmable read-only memory whose contents can be erased and reprogrammed using a pulsed voltage.

2.4.4.5. E1 malfunction

For current loop communication:

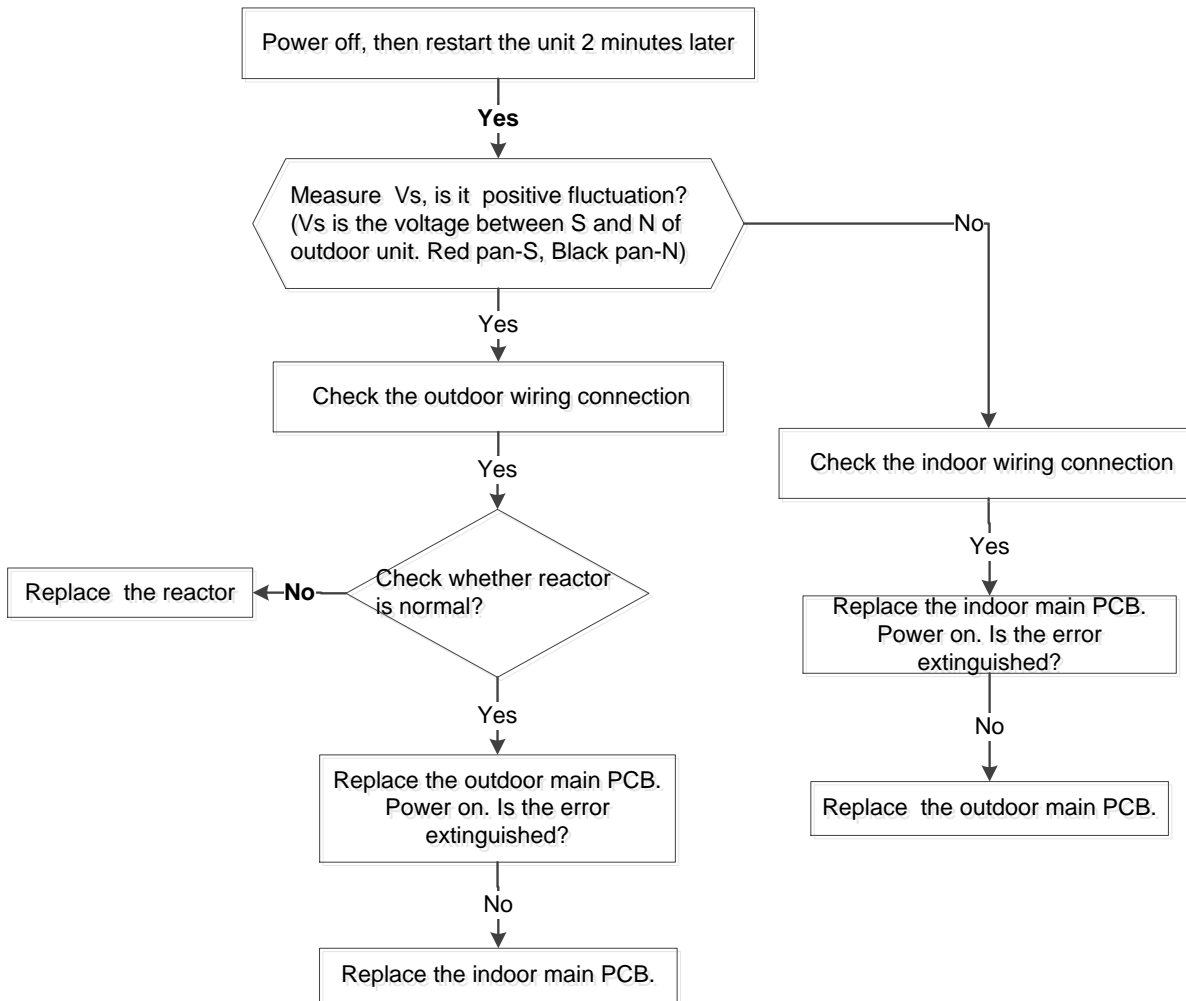

For 485 communication

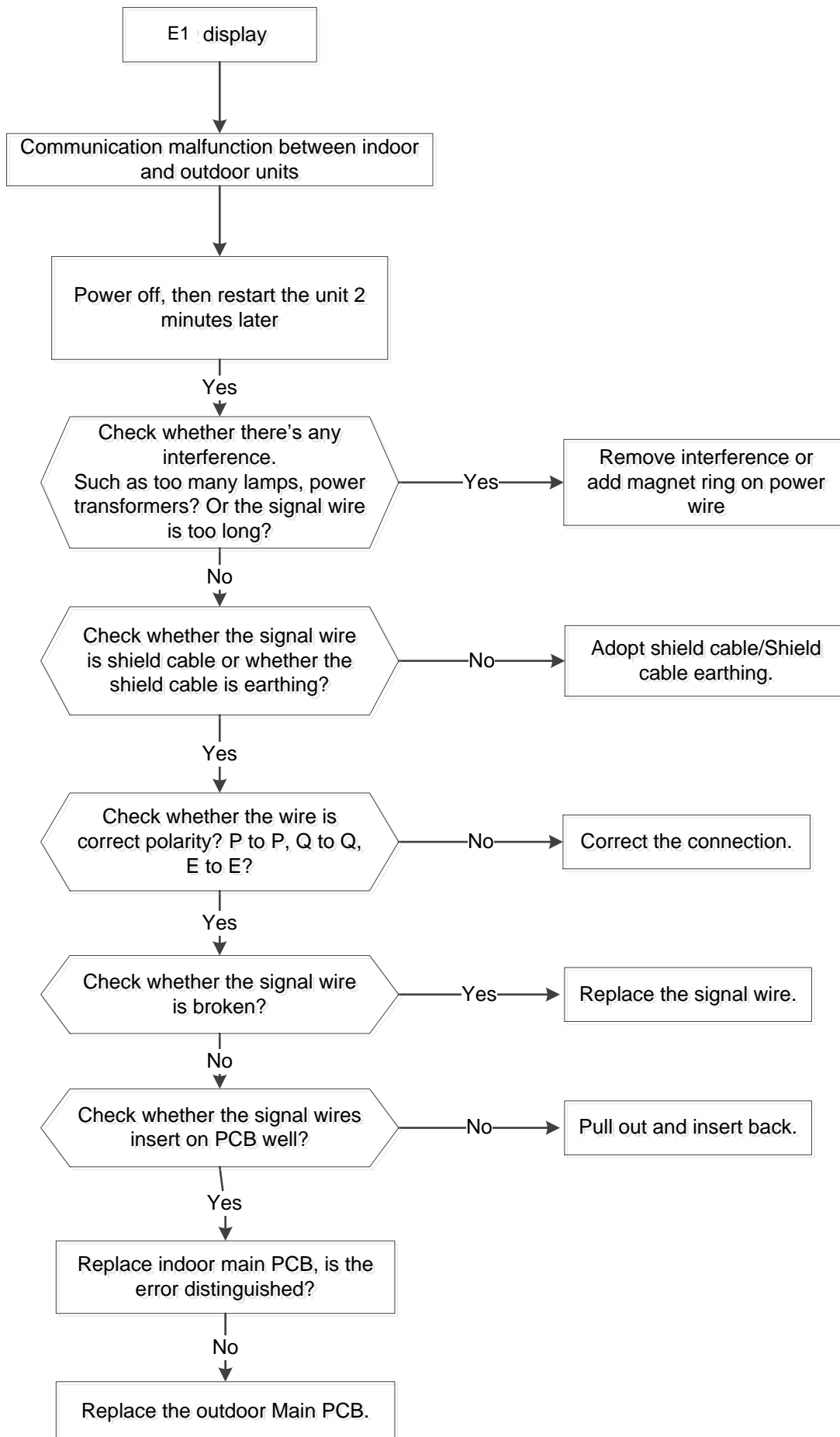

2.4.4.6. J4 malfunction

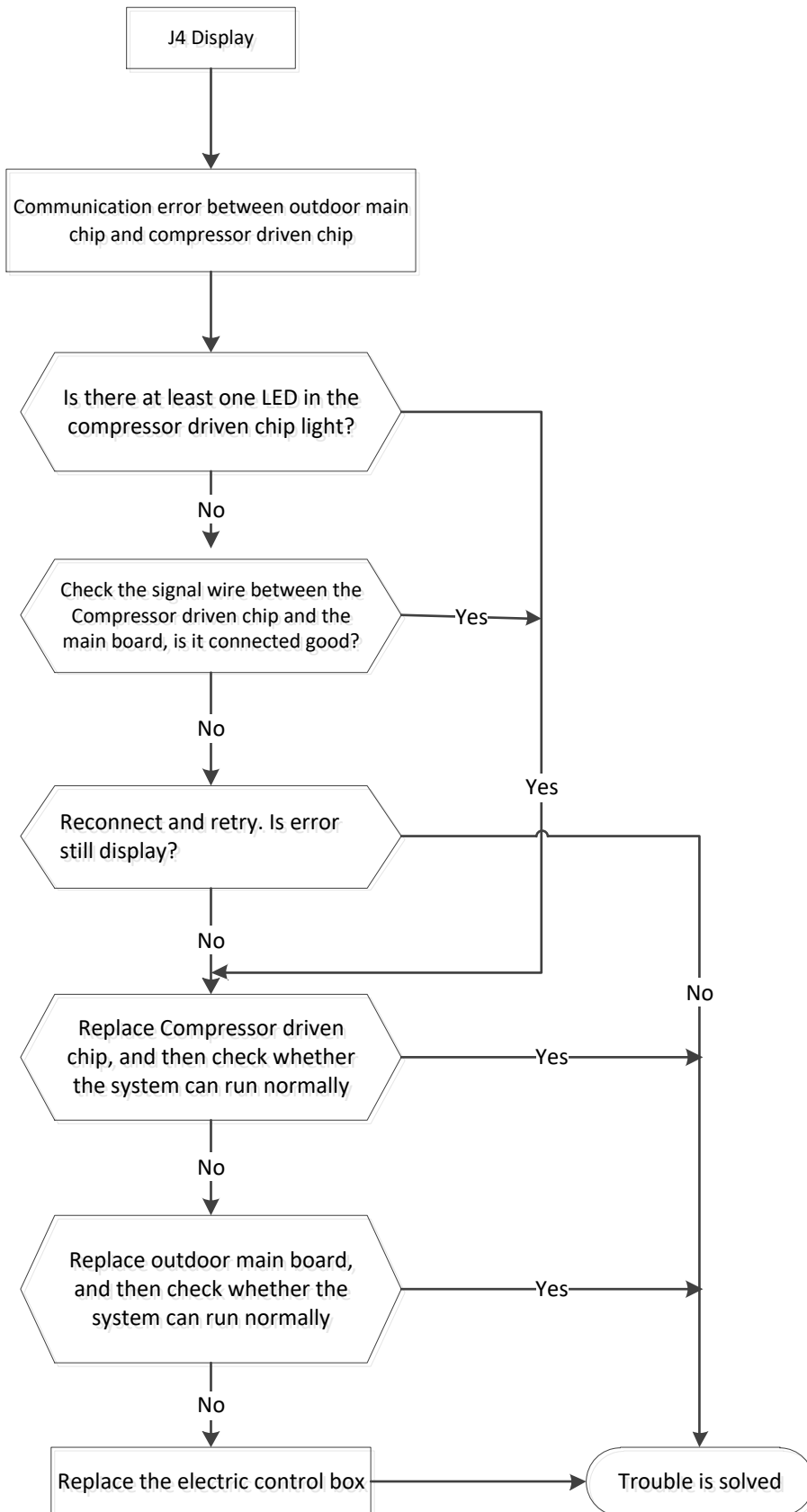

2.4.4.7. F1, F2, F3 malfunction

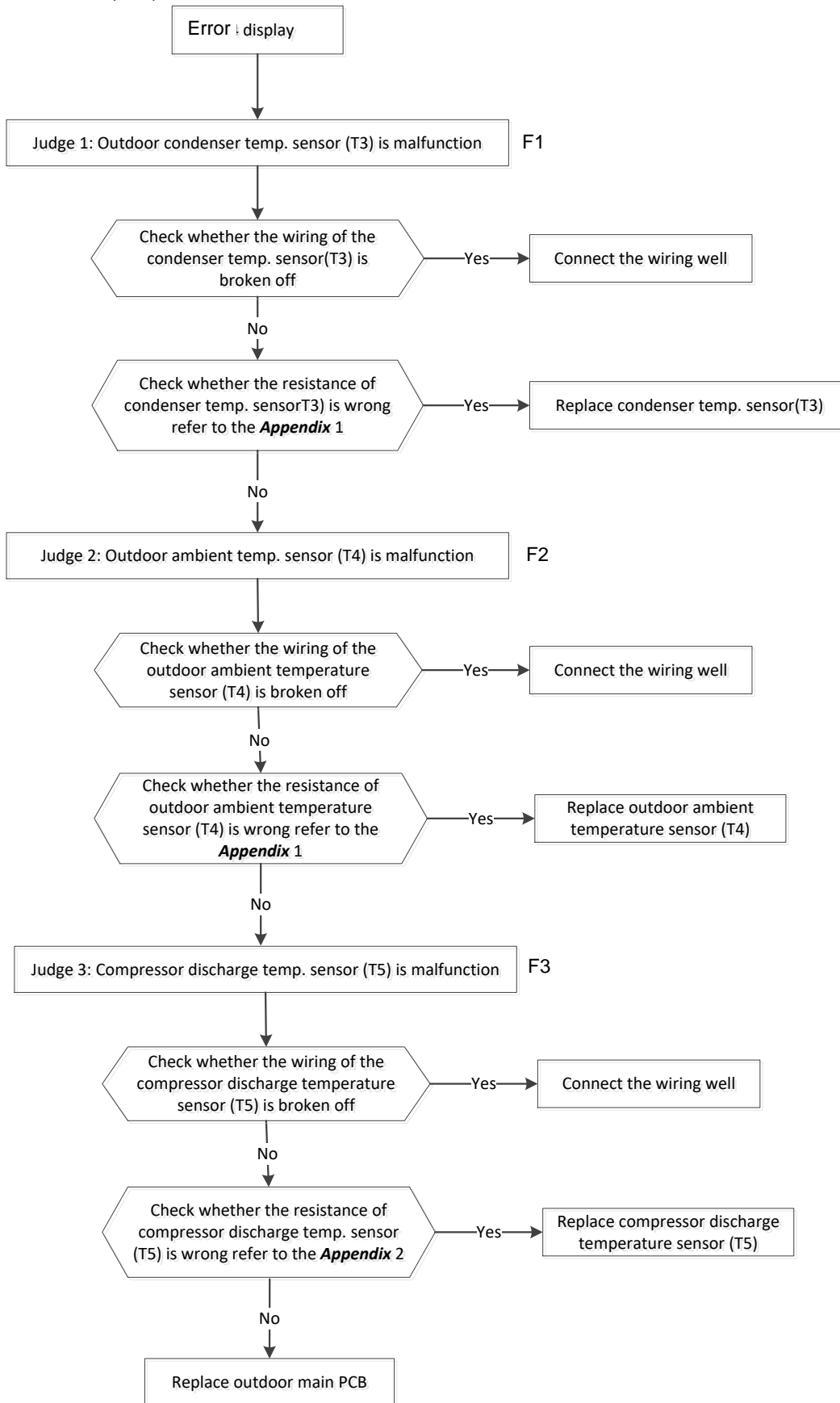

2.4.4.8. P6 malfunction

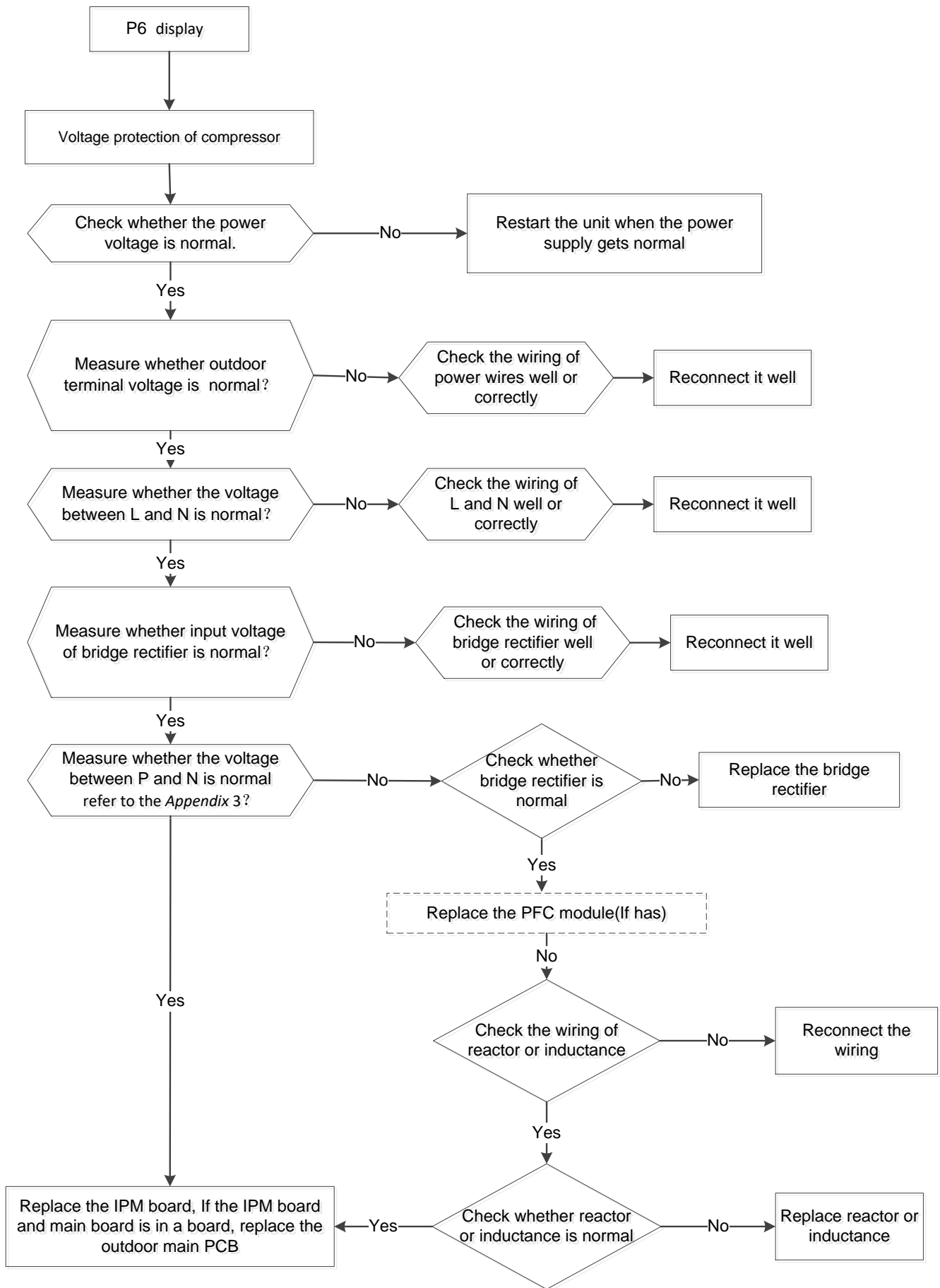

2.4.4.9. F5 malfunction
The same as E3 in indoor.

2.4.4.10. J5 malfunction

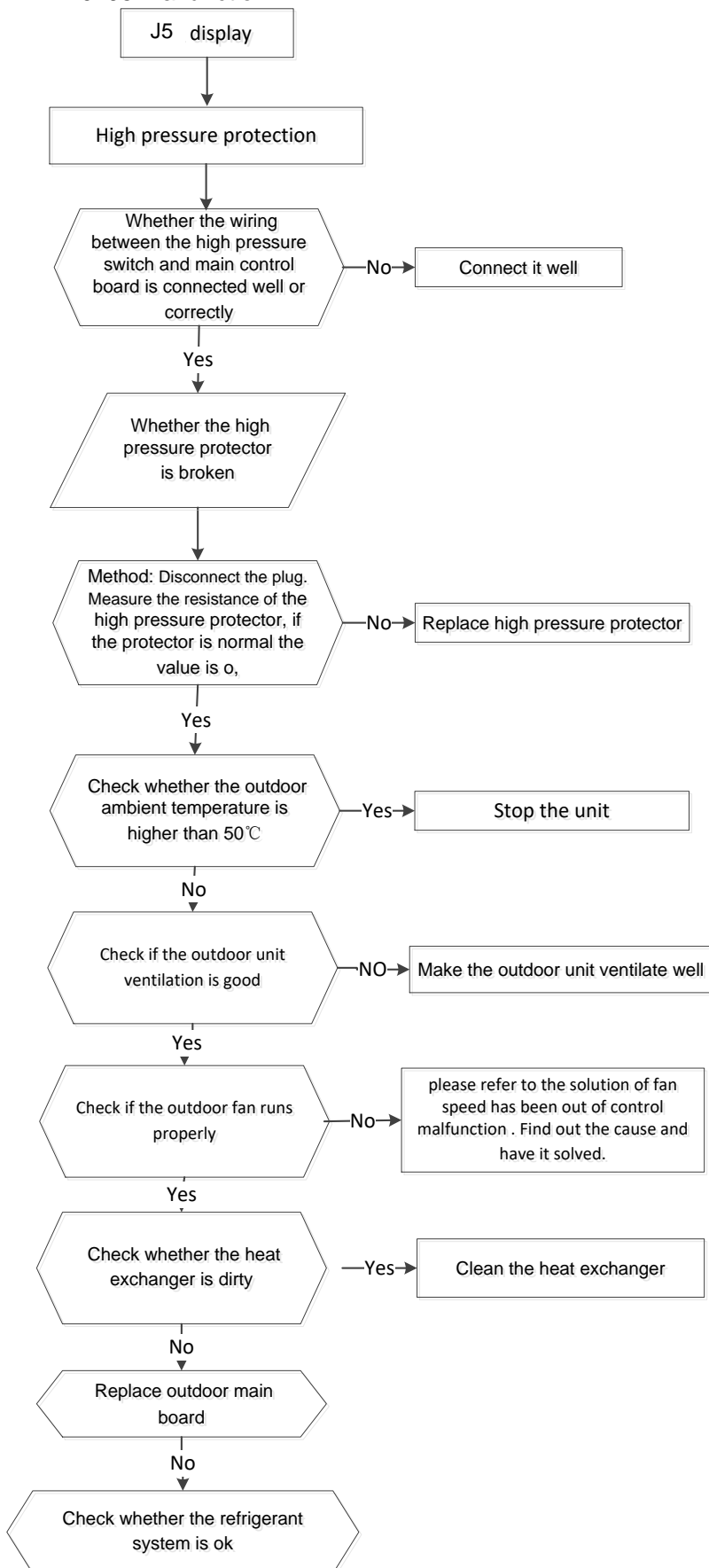

2.4.4.11. J6 malfunction

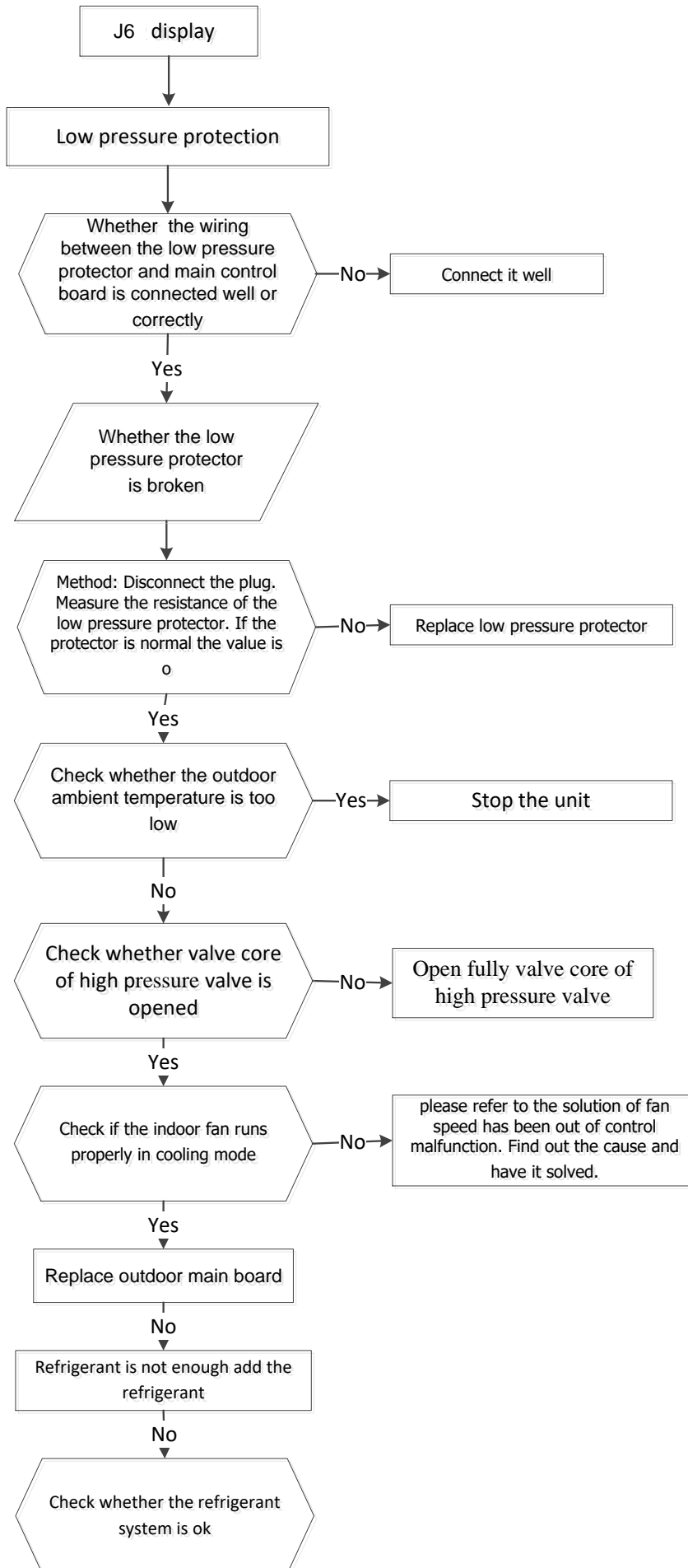

2.4.4.12. F0 malfunction

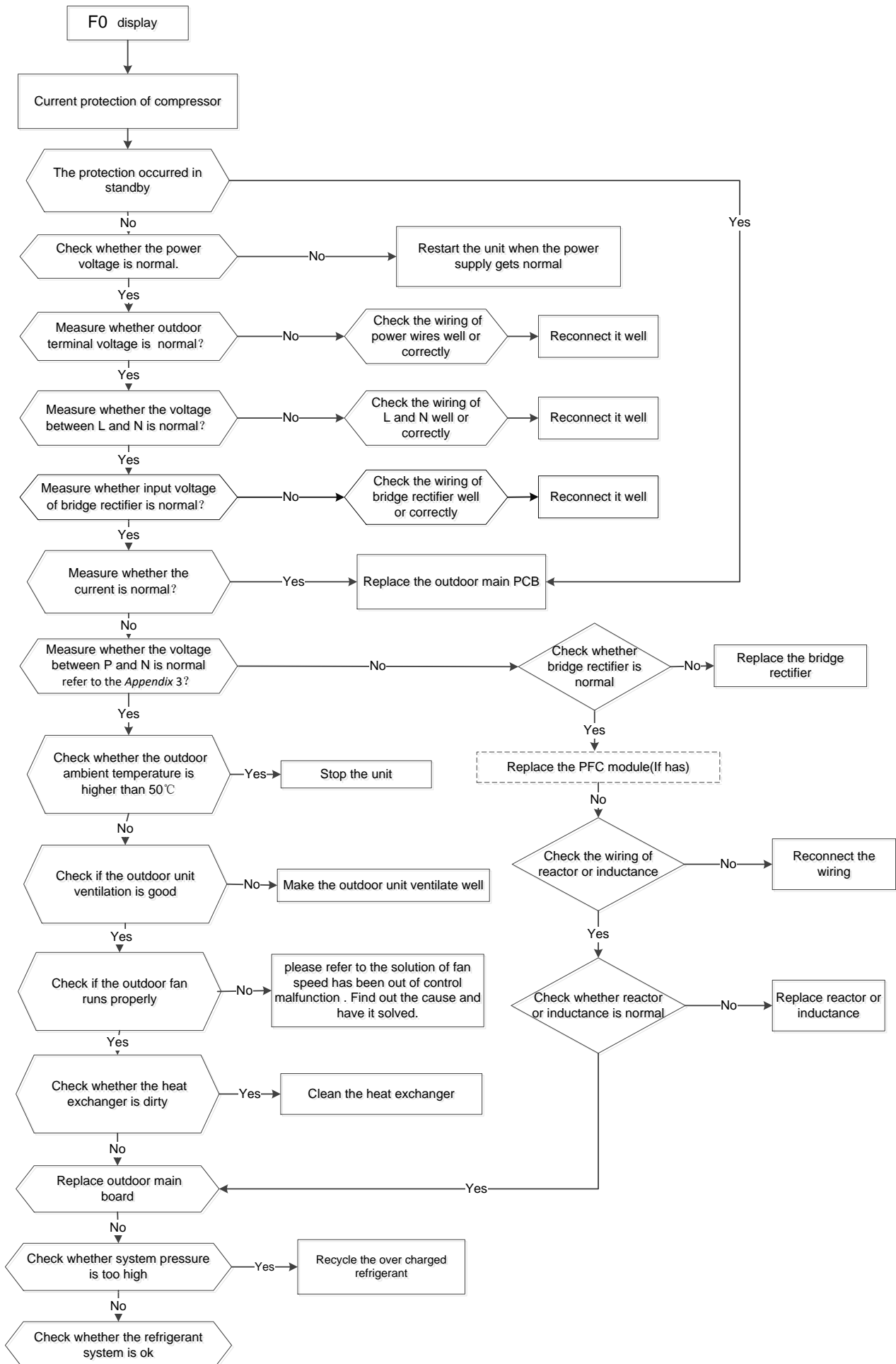

2.4.4.13. J2 malfunction

When compressor discharge temperature is higher than 115°C, the unit will stop, and unit runs again when compressor discharge temperature is lower than 90°C.

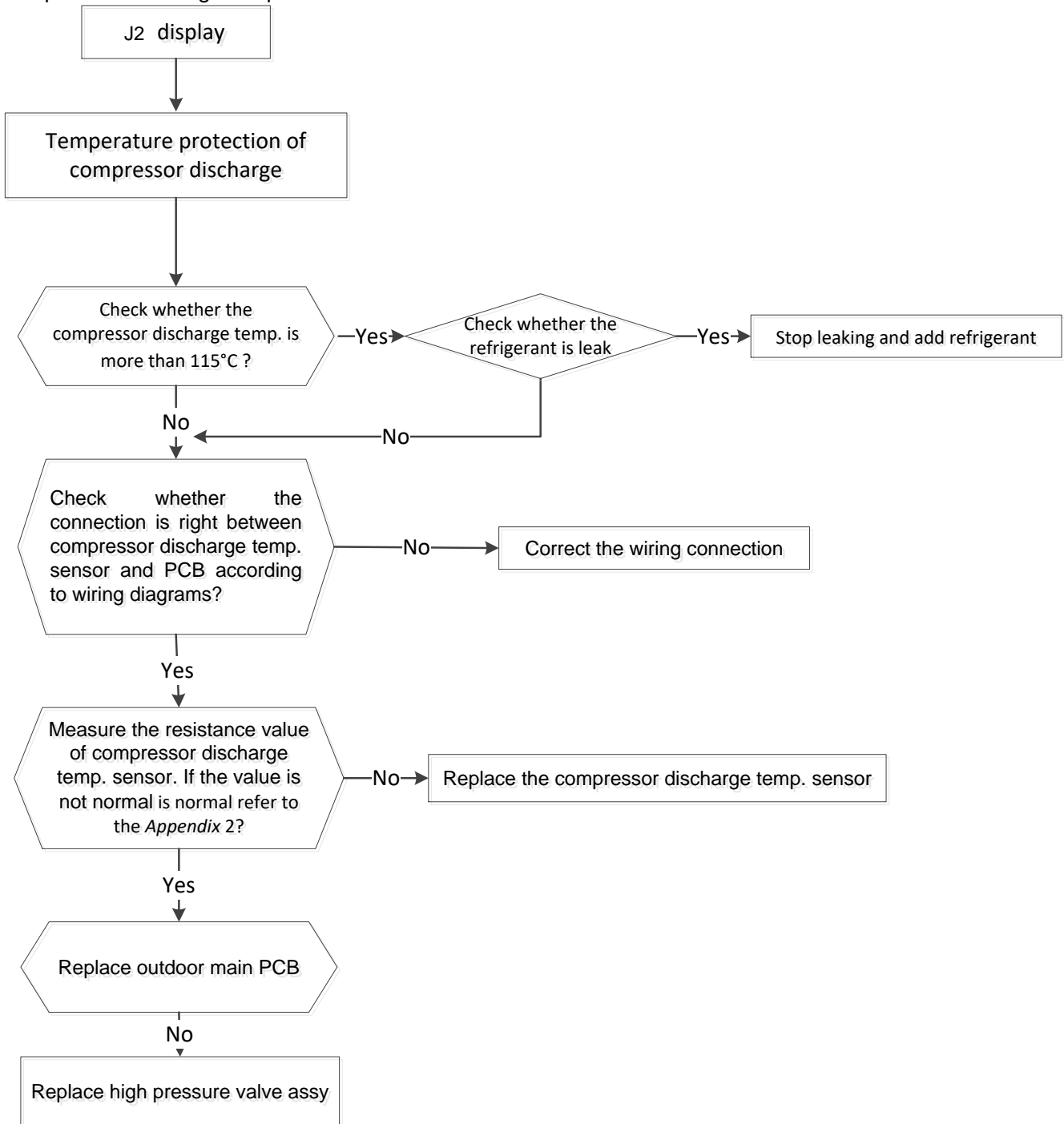

2.4.4.14. J1 malfunction

When condenser high temp. is more than 65°C, the unit will stop, and unit runs again when outdoor pipe temp. less than 52°C.

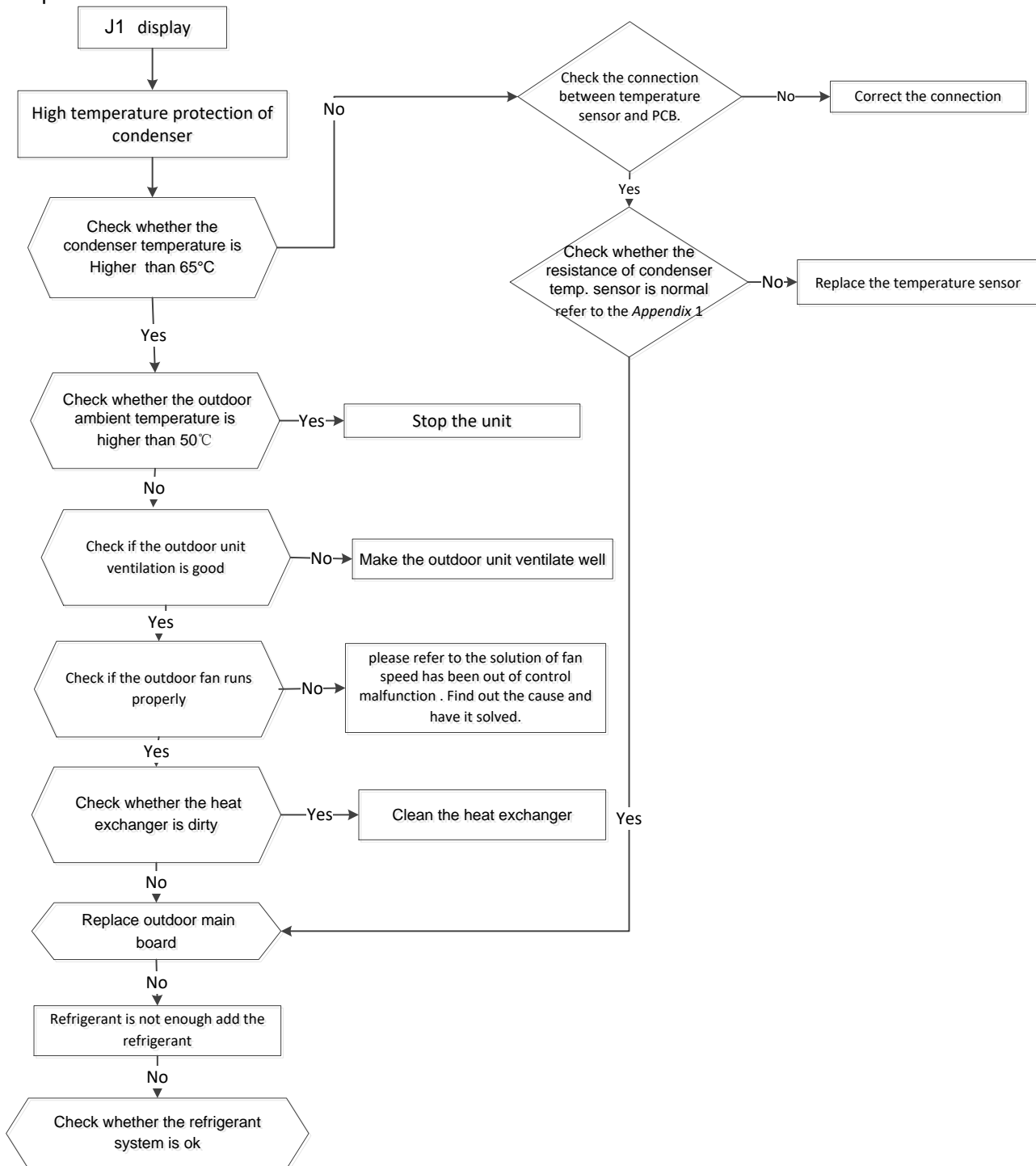

2.4.4.15. P0 malfunction

At first test the resistance between every two ports of U, V, W of IPM and P, N. If any result of them is 0 or close to 0, the IPM is defective. Otherwise, please follow the procedure below:

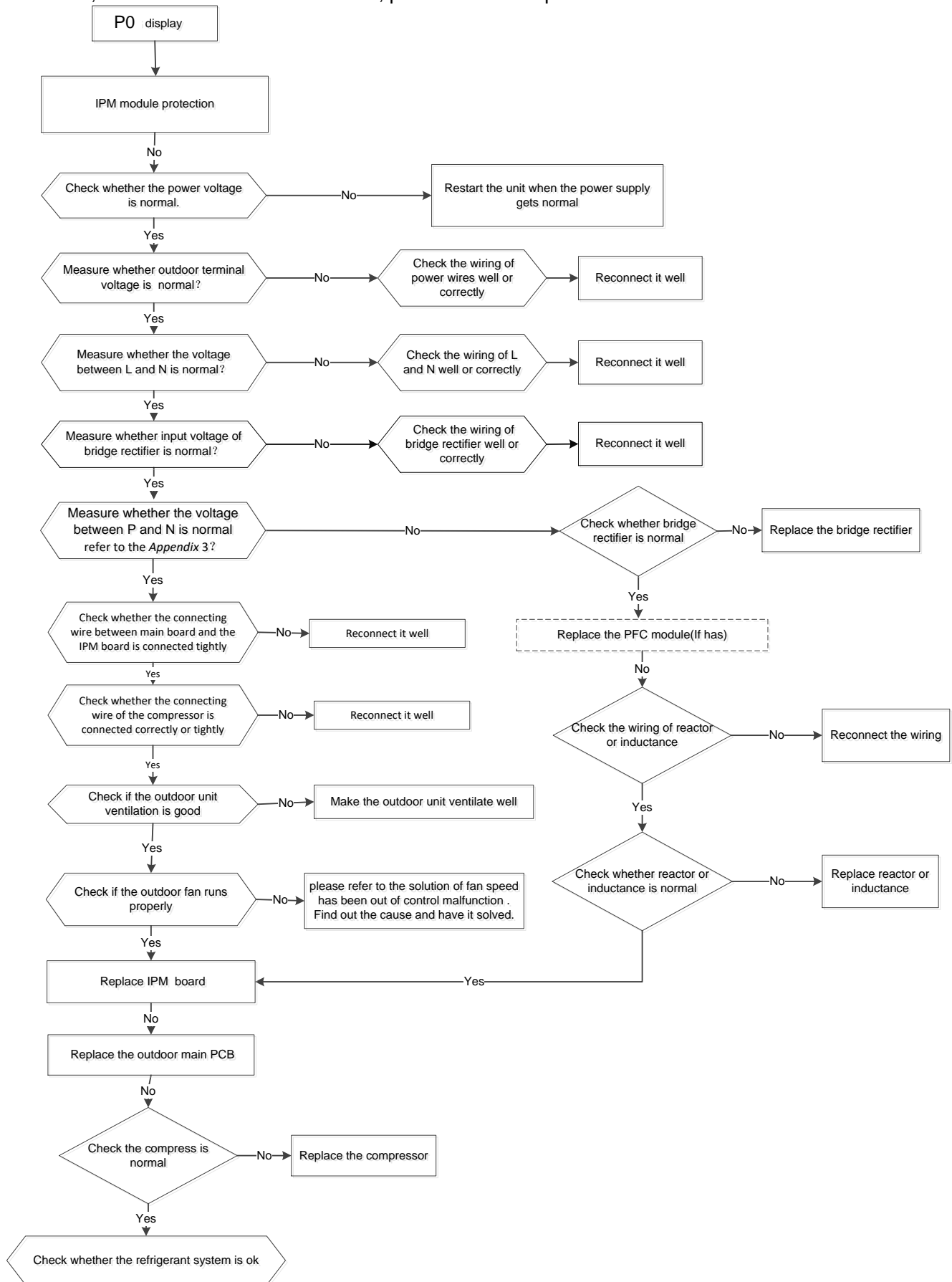

2.4.4.16. J0 malfunction

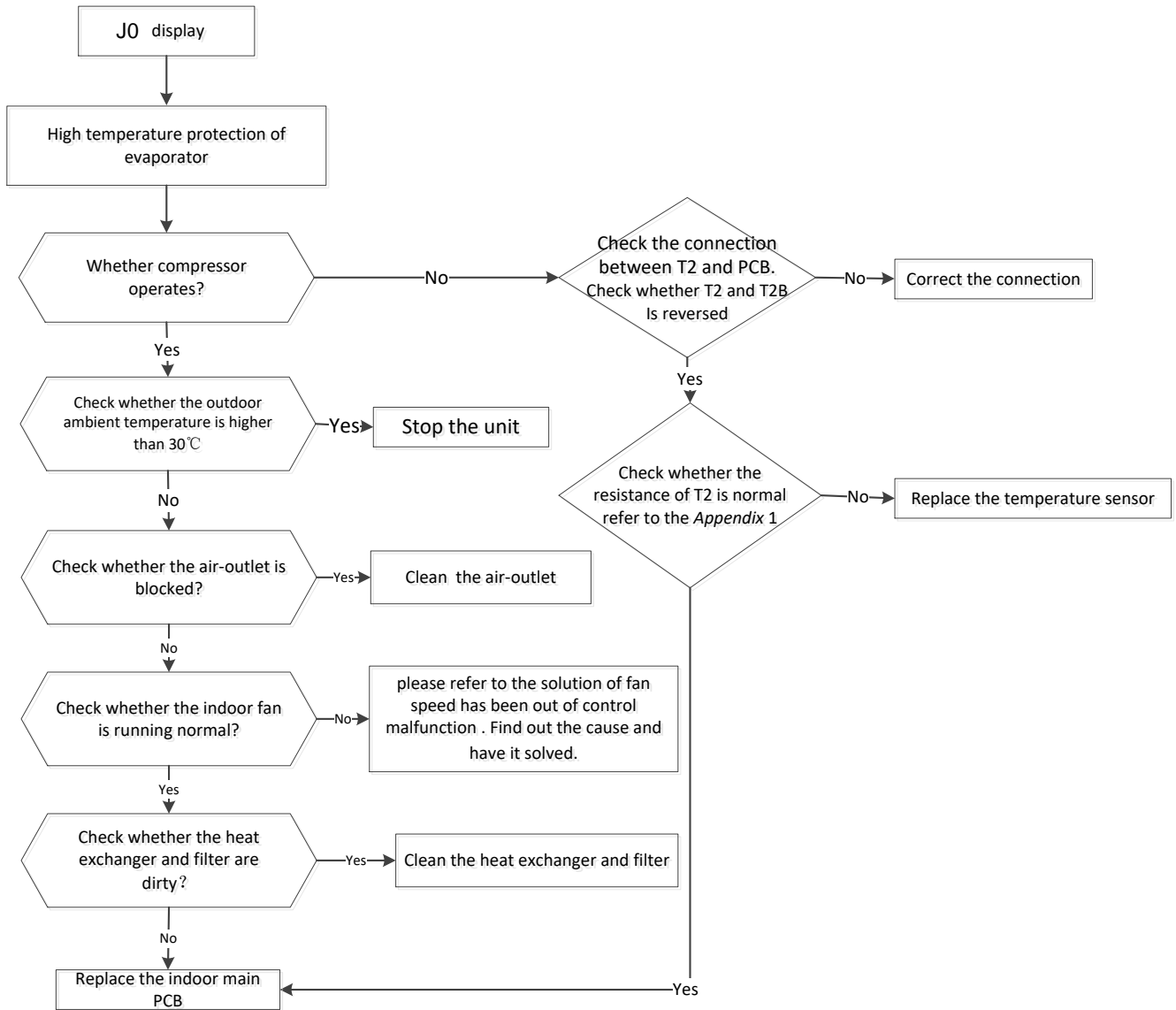

Appendix 1 Temperature Sensor Resistance Value Table (°C--K)

°C	K Ohm	°C	K Ohm	°C	K Ohm	°C	K Ohm
-20	115.266	20	12.6431	60	2.35774	100	0.62973
-19	108.146	21	12.0561	61	2.27249	101	0.61148
-18	101.517	22	11.5000	62	2.19073	102	0.59386
-17	96.3423	23	10.9731	63	2.11241	103	0.57683
-16	89.5865	24	10.4736	64	2.03732	104	0.56038
-15	84.2190	25	10.0000	65	1.96532	105	0.54448
-14	79.3110	26	9.55074	66	1.89627	106	0.52912
-13	74.5360	27	9.12445	67	1.83003	107	0.51426
-12	70.1698	28	8.71983	68	1.76647	108	0.49989
-11	66.0898	29	8.33566	69	1.70547	109	0.48600
-10	62.2756	30	7.97078	70	1.64691	110	0.47256
-9	58.7079	31	7.62411	71	1.59068	111	0.45957
-8	56.3694	32	7.29464	72	1.53668	112	0.44699
-7	52.2438	33	6.98142	73	1.48481	113	0.43482
-6	49.3161	34	6.68355	74	1.43498	114	0.42304
-5	46.5725	35	6.40021	75	1.38703	115	0.41164
-4	44.0000	36	6.13059	76	1.34105	116	0.40060
-3	41.5878	37	5.87359	77	1.29078	117	0.38991
-2	39.8239	38	5.62961	78	1.25423	118	0.37956
-1	37.1988	39	5.39689	79	1.21330	119	0.36954
0	35.2024	40	5.17519	80	1.17393	120	0.35982
1	33.3269	41	4.96392	81	1.13604	121	0.35042
2	31.5635	42	4.76253	82	1.09958	122	0.3413
3	29.9058	43	4.57050	83	1.06448	123	0.33246
4	28.3459	44	4.38736	84	1.03069	124	0.32390
5	26.8778	45	4.21263	85	0.99815	125	0.31559
6	25.4954	46	4.04589	86	0.96681	126	0.30754
7	24.1932	47	3.88673	87	0.93662	127	0.29974
8	22.5662	48	3.73476	88	0.90753	128	0.29216
9	21.8094	49	3.58962	89	0.87950	129	0.28482
10	20.7184	50	3.45097	90	0.85248	130	0.27770
11	19.6891	51	3.31847	91	0.82643	131	0.27078
12	18.7177	52	3.19183	92	0.80132	132	0.26408
13	17.8005	53	3.07075	93	0.77709	133	0.25757
14	16.9341	54	2.95896	94	0.75373	134	0.25125
15	16.1156	55	2.84421	95	0.73119	135	0.24512
16	15.3418	56	2.73823	96	0.70944	136	0.23916
17	14.6181	57	2.63682	97	0.68844	137	0.23338
18	13.9180	58	2.53973	98	0.66818	138	0.22776
19	13.2631	59	2.44677	99	0.64862	139	0.22231

Appendix 2

Unit: °C--K		Discharge temp. sensor table					
-20	542.7	20	68.66	60	13.59	100	3.702
-19	511.9	21	65.62	61	13.11	101	3.595
-18	483	22	62.73	62	12.65	102	3.492
-17	455.9	23	59.98	63	12.21	103	3.392
-16	430.5	24	57.37	64	11.79	104	3.296
-15	406.7	25	54.89	65	11.38	105	3.203
-14	384.3	26	52.53	66	10.99	106	3.113
-13	363.3	27	50.28	67	10.61	107	3.025
-12	343.6	28	48.14	68	10.25	108	2.941
-11	325.1	29	46.11	69	9.902	109	2.86
-10	307.7	30	44.17	70	9.569	110	2.781
-9	291.3	31	42.33	71	9.248	111	2.704
-8	275.9	32	40.57	72	8.94	112	2.63
-7	261.4	33	38.89	73	8.643	113	2.559
-6	247.8	34	37.3	74	8.358	114	2.489
-5	234.9	35	35.78	75	8.084	115	2.422
-4	222.8	36	34.32	76	7.82	116	2.357
-3	211.4	37	32.94	77	7.566	117	2.294
-2	200.7	38	31.62	78	7.321	118	2.233
-1	190.5	39	30.36	79	7.086	119	2.174
0	180.9	40	29.15	80	6.859	120	2.117
1	171.9	41	28	81	6.641	121	2.061
2	163.3	42	26.9	82	6.43	122	2.007
3	155.2	43	25.86	83	6.228	123	1.955
4	147.6	44	24.85	84	6.033	124	1.905
5	140.4	45	23.89	85	5.844	125	1.856
6	133.5	46	22.89	86	5.663	126	1.808
7	127.1	47	22.1	87	5.488	127	1.762
8	121	48	21.26	88	5.32	128	1.717
9	115.2	49	20.46	89	5.157	129	1.674
10	109.8	50	19.69	90	5	130	1.632
11	104.6	51	18.96	91	4.849		
12	99.69	52	18.26	92	4.703		
13	95.05	53	17.58	93	4.562		
14	90.66	54	16.94	94	4.426		
15	86.49	55	16.32	95	4.294	B(25/50)=3950K	
16	82.54	56	15.73	96	4.167		
17	78.79	57	15.16	97	4.045	R(90°C)=5KΩ±3%	
18	75.24	58	14.62	98	3.927		
19	71.86	59	14.09	99	3.812		

Appendix 3

Normal voltage of P and N			
208-240V(1-phase,3-phase)		380-420V(3-phase)	
In standby			
around 310VDC		around 530VDC	
In operation			
With passive PFC module	With partial active PFC module	With fully active PFC module	/
>200VDC	>310VDC	>370VDC	>450VDC

3. Controller

3.1 Wireless Remote Controller

3.1.1 RG51Q1/BGE

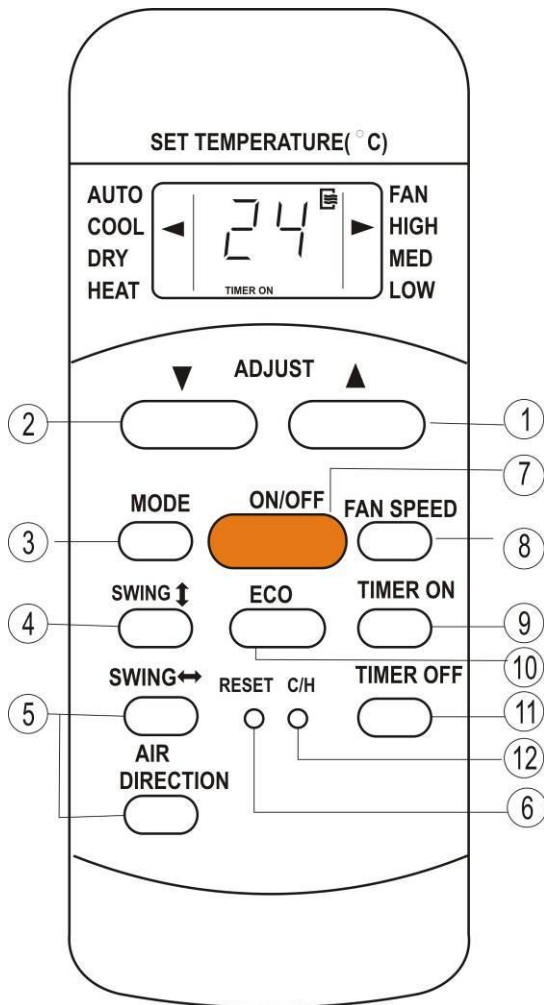

General Function for wireless remote controller:

Model	RG51Q1/BGE
Rated voltage	3.0V(2pieces of LR03 7 # batteries)
Min voltage for sending signal of CPU	2.4V
Effective receiving distance	8m~11m
Operation condition	-5~60℃

Buttons and functions

1. **Adjust ▼** : Decrease the set temp. Keeping pressing will decrease the temp with 1°C per 0.5s.
2. **Adjust ▲** : Increase the set temp. Keeping pressing will increase the temp with 1°C per 0.5s.
3. **MODE**: Once pressing, running mode will be selected in the following sequence:

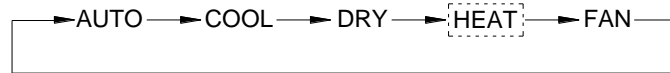

NOTE: No heating mode for cool only type unit.

4. **VERT SWING**: Used to stop or start horizontal louver movement or set the desired up/down air flow direction. The louver changes 6 degree in angle for each press. If keep pushing more than 2 seconds, the louver will swing up and down automatically.
5. **HORIZ SWING**: Used to stop or start vertical louver movement.
6. **AIR DIRECTION**: Used to set the desired up/down air flow direction. The louver changes 6 degree in angle for each press.
7. **ON/OFF**: For turning on or turning off the air conditioner.
8. **FAN SPEED**: Fan speed will be selected in following sequence once pressing this button:

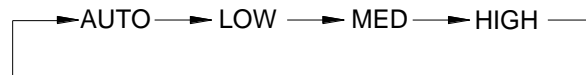

9. **TIME ON**: For time ON setting. Once pressing this button, the time will increase by 0.5 hour. When the set time exceeds 10 hours, pressing the button will increase the time by 1 hour. Adjusting the figure to 0.00 will cancel time ON setting.
10. **ECO**: Activate or turn off economic operation mode. It is suggested to turn on this function when sleeping. (Only available when remote controller is used with corresponding unit.)
11. **TIME OFF**: For time OFF setting. Once pressing this button, the time will increase by 0.5 hour. When the set time exceeds 10 hours, pressing the button will increase the time by 1 hour.

Adjust the figure to 0.00 will cancel time ON setting.

12. **C/H** (inner located): Press this button with a needle of 1mm to shift the mode between Cooling only and Cooling & Heating according to the feature of the machine.
13. **RESET** (inner located): Press this button with a needle of 1mm to cancel the current setting and reset remote controller.

3.1.2 RG51C/E

Remote Controller Specifications

Model	RG51C/E
Rated Voltage	3.0V(2pieces of LR03 7 # batteries)
Lowest Voltage of CPU Emitting Signal	2.0V
Reaching Distance	8m (when using 3.0 voltage, it can get 11m)
Environment Temperature Range	-5°C ~ 60°C

Introduction of Function Buttons on the Remote Controller

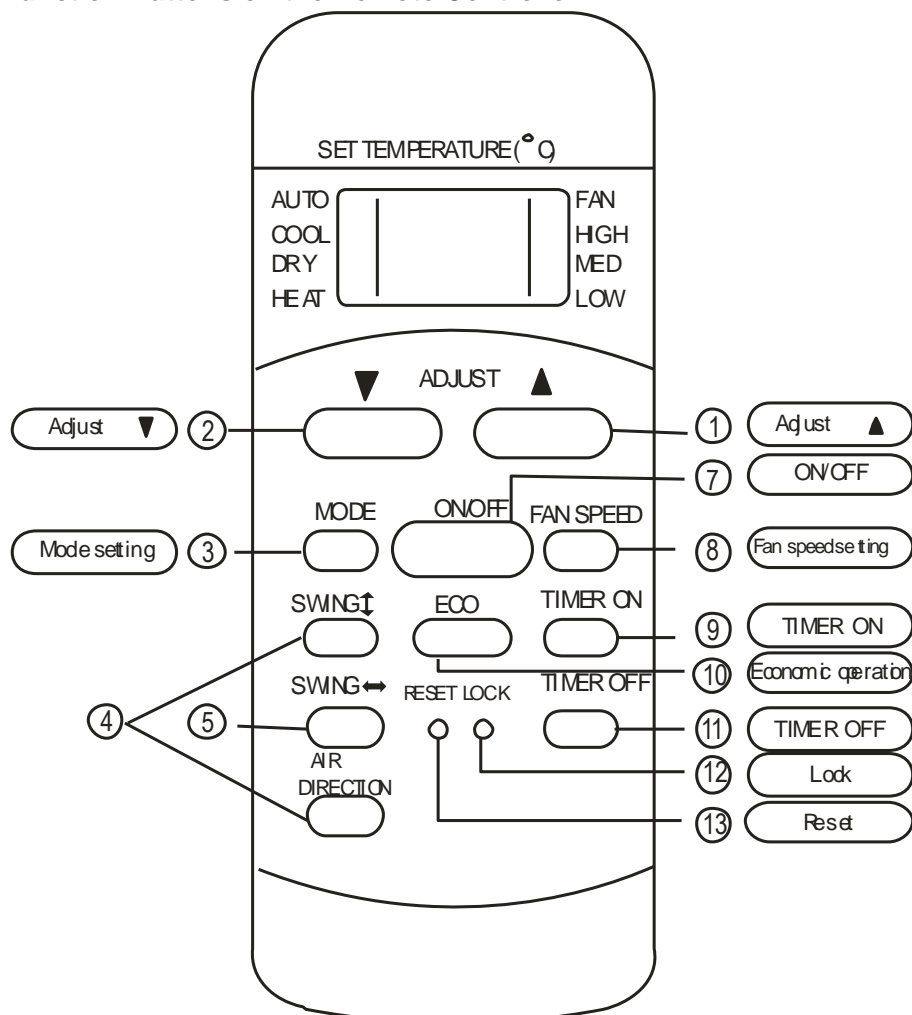

- Adjust ▼** : Decrease the set temp. Keeping pressing will decrease the temp with 1°C per 0.5s.
- Adjust ▲** : Increase the set temp. Keeping pressing will increase the temp with 1°C per 0.5s.
- MODE**: Once pressing, running mode will be selected in the following sequence:

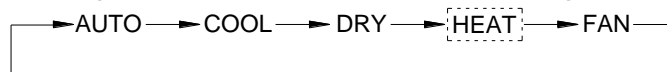

NOTE: No heating mode for cool only type unit.

4. VERT SWING: Used to stop or start horizontal louver movement. The louver will swing up and down automatically if push this button.

AIR DIRECTION: Used to set the desired up/down air flow direction. The louver changes 6 degree in angle for each press.

5. HORIZ SWING: Used to stop or start vertical louver movement.

6. FAN SPEED+ MODE: Press the Mode and Fan speed button simultaneously for 2 seconds. The remote

controls into faceplate setting state and the LCD shows F2. Press the TEMPUP(▲) to control the faceplate up and press the TEMP DOWN(▼) to control the faceplate down. Press any button to exit the faceplate setting state, then the LCD back to the normal display.

7. ON/OFF: For turning on or turning off the air conditioner.

8. FAN SPEED: Fan speed will be selected in following sequence once pressing this button:

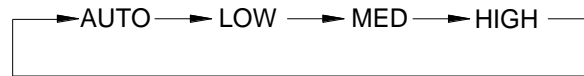

9. TIME ON: For time ON setting. Once pressing this button, the time will increase by 0.5 hour. When the set time exceeds 10 hours, pressing the button will increase the time by 1 hour. Adjusting the figure to 0.00 will cancel time ON setting.

10. ECO: Select this function during the sleeping time. It can maintain the most comfortable temperature and save energy. This function is available on COOL, HEAT or AUTO mode only .

NOTE: While the unit is running under Energy-saving mode, it would be cancelled if press MODE, FAN SPEED or ON/OFF button.

11. TIME OFF: For time OFF setting. Once pressing this button, the time will increase by 0.5 hour. When the set time exceeds 10 hours, pressing the button will increase the time by 1 hour.

Adjust the figure to 0.00 will cancel time ON setting.

12. LOCK (inner located): Push this button to lock in all the current settings, and the remote controller will not accept any operation except that of the LOCK. Use the LOCK mode when you want to prevent settings from being changed accidentally. Press the LOCK button again to cancel the LOCK function. A lock symbol will appear on the remote controller display when the lock function is activated.

13. RESET (inner located): Once the recessed RESET button is pressed, all of the current settings will be cancelled and the controller will return to the initial settings..

3.1.3 R51M/(C)E

Remote Controller Specifications

Model	R51M/(C)E
Rated Voltage	3.0V
Reaching Distance	8m
Environment Temperature Range	-5°C ~ 60°C

Introduction of Function Buttons on the Remote Controller

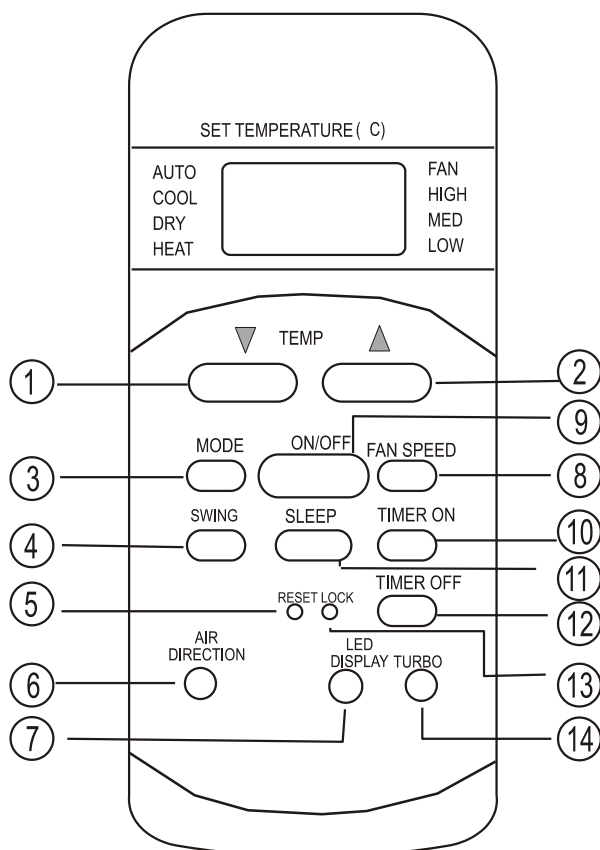

- 1. Adjust ▼** : Decrease the set temp. Keeping pressing will decrease the temp with 1°C per 0.5s.
- 2. Adjust ▲** : Increase the set temp. Keeping pressing will increase the temp with 1°C per 0.5s.
- 3. MODE**: Once pressing, running mode will be selected in the following sequence:

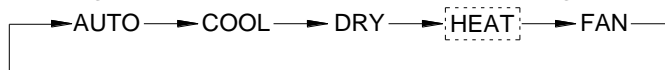

NOTE: No heating mode for cool only type unit.

- 4. SWING**: Used to stop or start horizontal louver movement. The louver will swing up and down automatically if push this button.
- 5. RESET** (inner located): Once the recessed RESET button is pressed, all of the current settings will be cancelled and the controller will return to the initial settings.
- 6. AIR DIRECTION**: Press this button to change the swing angle of the louver. The swing angle of the louver is 60 for each press. When the louver swing at a certain angle which would affect the cooling and heating effect of the air conditioner, it would automatically change the swing direction. No symbol will appear in the display area when press this button. (Not applicable to units without this function).
- 7. LED**: Press this button to clear the digit display in the air conditioner, press it again to activate it (Not available for the units without LED display window).
- 8. FAN SPEED**: Fan speed will be selected in following sequence once pressing this button:

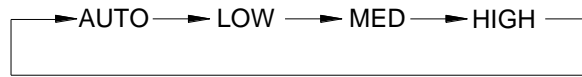

9. ON/OFF: For turning on or turning off the air conditioner

10. TIME ON: For time ON setting. Once pressing this button, the time will increase by 0.5 hour. When the set time exceeds 10 hours, pressing the button will increase the time by 1 hour. Adjusting the figure to 0.00 will cancel time ON setting.

11. SLEEP: Press this button to go into the Energy-Saving operation mode. Press it again to cancel. This function is only can be used on COOL, HEAT and AUTO mode and maintain the most comfortable temperature for you.

12. TIME OFF: For time OFF setting. Once pressing this button, the time will increase by 0.5 hour. When the set time exceeds 10 hours, pressing the button will increase the time by 1 hour.

Adjust the figure to 0.00 will cancel time ON setting.

13. LOCK (inner located): Push this button to lock in all the current settings, and the remote controller will not accept any operation except that of the LOCK. Use the LOCK mode when you want to prevent settings

from being changed accidentally. Press the LOCK button again to cancel the LOCK function. A lock symbol will appear on the remote controller display when the lock function is activated.

14. TURBO: Push this button to activate/cancel the Turbo function which enables the unit to reach the preset temperature in the shortest time. On cooling mode, the unit will blow strong cooling air with super high fan speed. On heating mode (applicable to the unit adopts PTC only), the PTC will bring fast heating operation.

3.2 Wired Remote Controller

3.2.1 KJR-12B



Name and functions of buttons on the wire controller

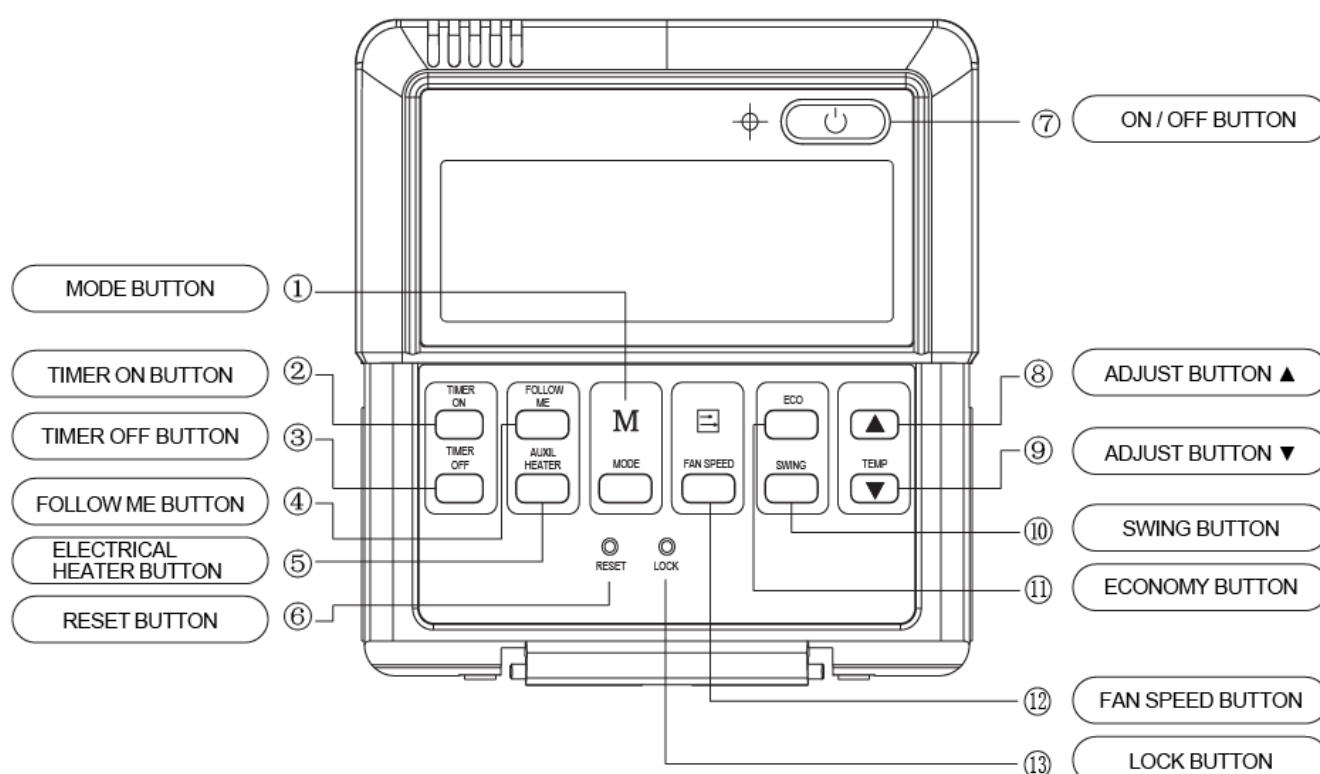

1. Mode button: When press this button, the operation mode change as the following sequence:

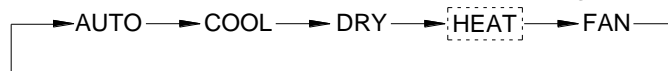

Remark: For the cooling only model, the heating mode is skipped.

2. Timer on button: Press this button, timer on function is active. Then every press, the time increase 0.5h, after 10h, 1h increasement after each press. If cancel this Function, just set it to "0.0"
3. Timer off button: Press this button, timer off function is active. Then every press, the time increase 0.5h, after 10h, 1h increasement after each press. If cancel this function, just set it to "0.0" .
4. Follow me button: When under cool, heat and auto mode, press this button, follow me function is active. Press again, this function is ineffective.
5. Electrical heater button: If press this button in heat mode, electrical heater function become ineffective.
6. Reset button (hidden): Use a 1mm stick to press in the little hole , then the current setting is canceled . The wire controllers enter into original state.
7. ON/OFF button: When in off state, press this button, the indicator is on, the wire controller enter into on state, and send setting information to indoor PCB. When in on state, press this button, the indicator is off, and send instruction. If timer on or timer off has been set, it cancel this setting then send instruction to stop the machine.

8. Adjust button: Set indoor temperature up. If press and hold on, it will increase at 1degree per 0.5 second.
9. Adjust button: Set indoor temperature down. if press and hold on, it will decrease at 1degree per 0.5 Second.
10. Swing button: First press, start swing function; second press, stop swing. (Match to some model with swing function).
11. Economy operation button: press this button, the indoor unit operates in economy mode, press again, exit this mode (it may be ineffective for some models)
12. Fan speed button: press this button consecutively; the fan speed will circle as follow:

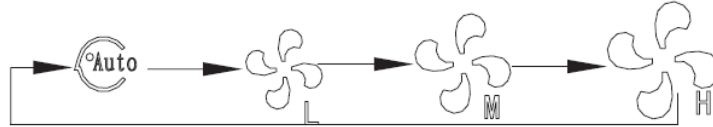

13. Lock button (hidden): When you push the LOCK button, all current settings are locked in and the wire controller does not accept any operation except that of the LOCK button. Use the lock mode when you want to prevent setting from being changed accidentally or play fully. Push the LOCK button again when you want to cancel the LOCK mode.

Name and function of LCD on the wire controller

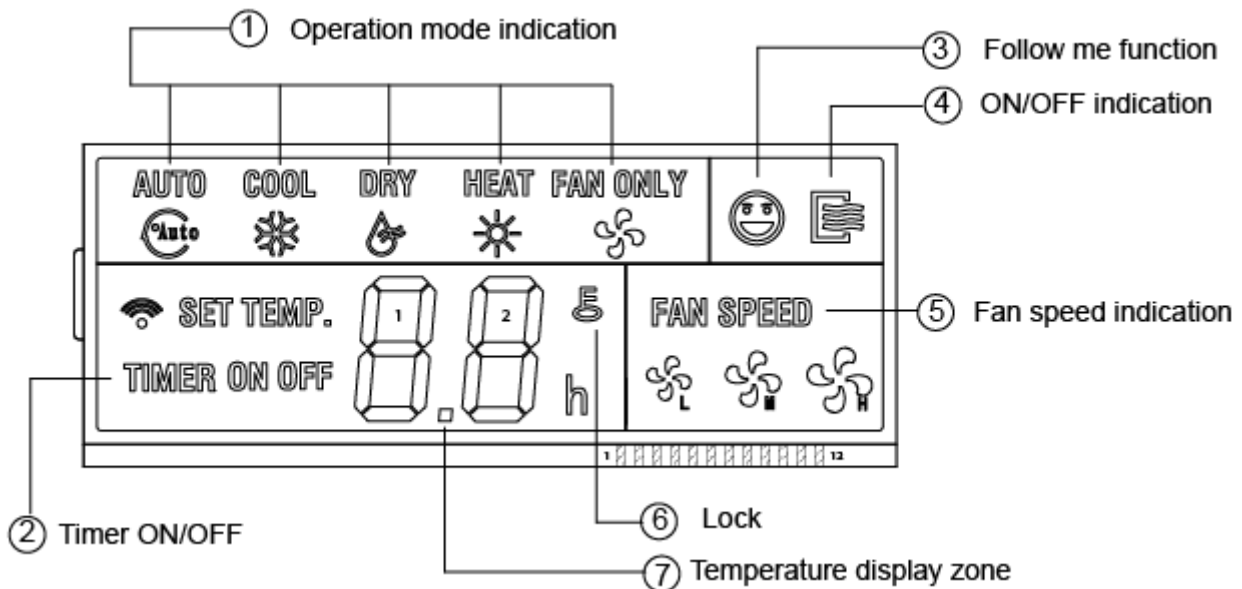

1. Operation mode indication: When press” MODE” button, the following mode can be selected in circle. Auto Cool Dry Heat Fan only Auto.
Auto→ Cool→ Dry →Heat→ Fan only →Auto
For cooling only model, heat mode is skipped.
2. Timer: When adjust setting on time or only on time is set, the “ON” is lighted. When adjust setting off time or only off time is set, the” OFF” is lighted. If on and off timer are both set, the “ON” and “OFF” are both lighted.
3. Follow me function: There is a temperature sensor inside the wire controller, after setting temperature, it will compare the two temperatures, and the space of wire controller will be the same as setting temperature. It is available under cooling, heating, auto mode.
4. ON/OFF indication: When it is on, the icon display, otherwise it is extinguished.
5. Fan speed indication: There are four fan modes: low, middle, high, auto. For some models, no middle fan then the middle fan is seen as high speed.
6. Lock: When the "LOCK" button is pressed, the icon appears and other buttons is unable, press again, the icon disappears.
7. Temperature display zone: Generally it displays setting temperature; it can be adjusted by press temperature button▲and▼ .But in fan mode, no display here.

Remark:

The wired controller will reset to factory setting with auto mode, auto fan and 24°C setting temperature when the air conditioner restarts after power failure.

And this may cause inconsistent displays on the wired controller and on the air conditioner. You need to readjust the running status through the wired controller.

Installation

Wiring Principle Sketch:

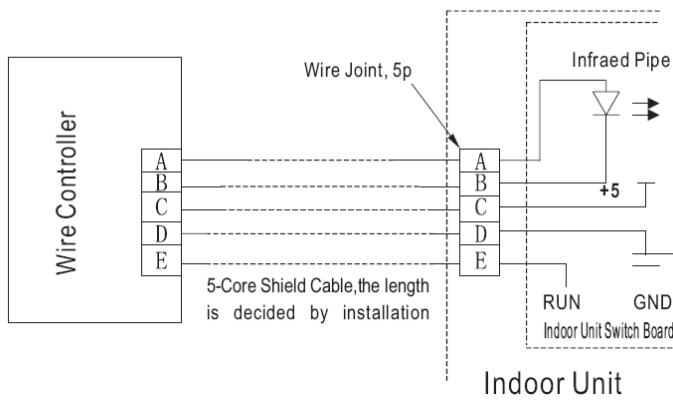

Installation Notice:

When the air conditioner needs the constant frequency wire controller, be sure adding a wire joint with 5 terminal named A, B, C, D, E in indoor unit, and fixing an infrared emitter whose anode and cathode connecting with A and B near the receiver in the indoor unit switch board, then connecting the terminal +5v, GND, Run in the switch board to C,D,E respectively.

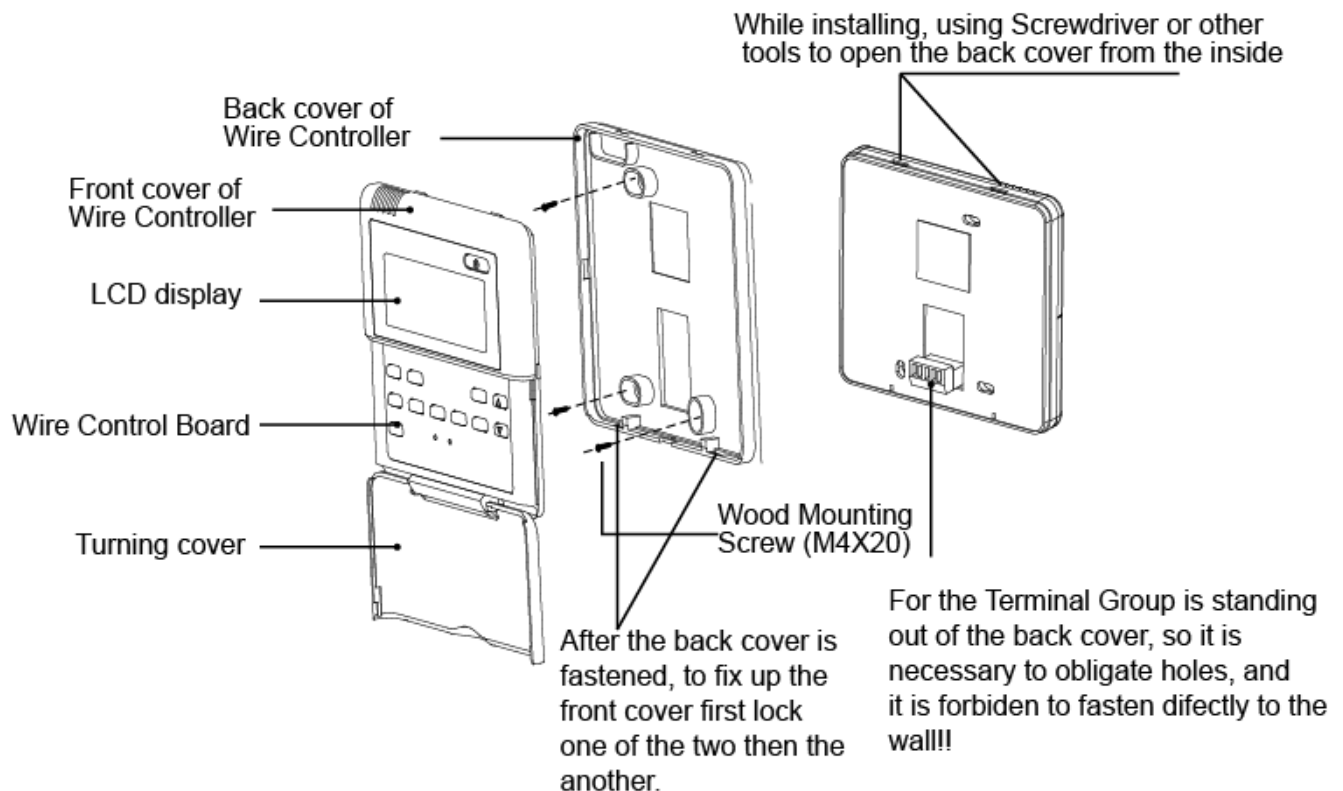

NOTE

- The connecting wire should be a little longer as to take away the switch board easily for maintenance.
- The connecting wire should be a little longer as to take away the controller easily for maintenance.